

ZKOVE



800 RALLY

INSTRUCTION MANUAL

Tibet New Summit Motorcycle Co., Ltd

To the owner

Instruction Manual for The Two-wheeled Motorcycle 800X RALLY

1st Edition (January 2024)

First of all, congratulations on your purchase of a brand new KOVEMOTO!

If you choose products of KOVEMOTO, you will become a member of the KOVEMOTO family.

This Instruction Manual introduces the main specifications, basic structure, adjustment method and maintenance knowledge of the motorcycle. It will guide you to master the basic operation of the motorcycle and eliminate or reduce common faults, which can effectively ensure driving safety, play the best performance of the vehicle, and improve the service life of the vehicle.

This Instruction Manual contains the introduction of the basic configuration of the motorcycle. The contents and pictures are for reference only, please refer to the physical object.

Due to the production time, user needs and design improvements, the actual motorcycle may be different from the contents of the Manual. We reserve the right to make changes at any time, and we will no longer notify and assume any obligations. Sorry for any inconvenience caused.

The Instruction Manual is one of the necessary accessories of the motorcycle, and when it is sold to others, it should be attached to the motorcycle.

The copyright of this Instruction Manual belongs to the company, and no reproduction is allowed without the written consent of the company, and violators will be prosecuted.

To ensure your safety, and increase your riding pleasure:

- Please read the Instruction Manual carefully.
- Please follow all recommendations and procedures in the Instruction Manual.
- Please pay close attention to the safety information recorded in the Instruction Manual and pasted on the motorcycle body.

Safety Precautions

The safety of you and others is very important, and the safe driving of this motorcycle is an important responsibility.

To help you make an informed decision about your safety, we provide steps and other information on the safety label and in the Instruction Manual to remind you. This information is intended to alert you to the potential danger of harm to you or others.

It is impractical for us to list all the hazards associated with motorcycle riding and maintenance, and you must make the right judgment yourself.

It is forbidden to install electrical equipment, because the battery used in the motorcycle is a lithium battery. Its battery capacity is small, and the installation of electrical equipment may cause a loss of power. The motorcycle is equipped with a high-speed engine. For your driving safety, it is recommended that you reduce violent driving.

You'll see important security information in a variety of forms, including:

- Safety labels on the body of a motorcycle;
- The safety information is preceded by a safety warning symbol  and one of the following three warnings : Caution, danger, and warning.

The meanings of the three warnings are as follows:

 **Caution** - If you do not follow the instructions, you may be injured.

 **Danger** - If you do not follow the instructions, you will cause serious casualties.

 **Warning** - If you do not follow the instructions, you will cause serious casualties.

Other important information is listed under the following headings:

Caution - Information to help you avoid damage to your motorcycle, other property, or the environment.

Content

Motorcycle safety 4

Operating instructions 13

Maintenance 25

Troubleshooting 52

Relevant information 62

Technical parameters 72

Motorcycle safety

This section contains important information about the safe riding of motorcycles, please read this section carefully.

Safety instructions	5
Safety precautions	8
Riding precautions	9
Spare parts and modifications	12
Loading guide	12

Safety instructions

To enhance your driving safety, please follow these guidelines:

- Perform all routine and routine inspections as specified in the Instruction Manual.
- Before filling the tank, turn off the engine and keep away from sparks and open flames.
- Do not start the engine for a long time in a closed or semi-closed space, because the exhaust gas contains carbon monoxide, which is a toxic gas and can be fatal.

Always wear a helmet

It has been proven that helmets and protective clothing can significantly reduce the chance of injury to the head and other parts, and reduce the degree of injury. Therefore, please be sure to wear a certified motorcycle helmet and protective clothing when driving.

Before the ride

Make sure you're in good physical condition, paying attention, and not drinking or taking medication. Make sure to wear a certified motorcycle helmet and protective clothing, keep your hands on the handlebars and your feet on the footpeg, and tilt your body when turning. Do the above moves even when the motorcycle stops.

Take time to study and practice

Even if you have driven other motorcycles, you should practice riding this motorcycle in a safe area to familiarize yourself with the operation and operation of this motorcycle and adapt to the size and weight of the motorcycle.

Have a sense of protection when riding

Always pay attention to the vehicles around you, do not think that other drivers can see you, always be prepared to make emergency brakes or avoid detours.

Make yourself easier to see

Especially at night, wear bright reflective clothing to make yourself more eye-catching, stop so that other drivers can see you, turn on the signal light before turning or changing the lane, and when necessary, use the horn to remind pedestrians.

Don't drink and ride

Alcohol and driving are not compatible. Never exceed your personal ability when driving, and do not exceed the speed specified by the vehicle, fatigue and negligence will weaken your ability to make correct judgments and safe driving.

Keep your motorcycle in a safe state

It is important to take good care of your motorcycle so that your motorcycle is always in good condition. Check your motorcycle before each ride and complete all recommended maintenance and repairs. **Do not modify motorcycles or add accessories that will affect safety without authorization, and overload is strictly prohibited.**

Dealing with incidents

Your personal safety is your first priority. If you or anyone else is injured, you should first carefully evaluate the severity of the injury and determine whether it is safe to continue driving, and call for emergency assistance if necessary. If other persons or vehicles are involved in a collision, the applicable local laws and regulations should also be followed.

If you decide to continue driving, first turn the ignition switch to the “” (off) position, and then evaluate the condition of the motorcycle. Check whether there is oil leakage, check whether the key nuts and bolts are fastened, and check the steering handle, steering column, brake and wheel to ensure that the personnel and vehicle are safe. Please drive slowly and carefully.

Your motorcycle may have suffered damage that will not be immediately apparent, please submit it to a special repair shop or a qualified special repair shop of KOVEMOTO for a thorough inspection as soon as possible.

Carbon monoxide hazard

The exhaust gas contains toxic carbon monoxide, a colorless and odorless gas, and inhaling higher concentrations of carbon monoxide can cause people to lose consciousness and may even be fatal.

Do not start the engine for long periods of time in a garage or other enclosed space.

Warning

- If the engine is started for a long time in a closed or semi-closed space, it may cause a rapid accumulation of toxic carbon monoxide gas.
- Inhaling this colorless, odorless gas causes rapid loss of consciousness and death.
- Motorcycle engines should only be started in well ventilated outdoor areas.

Safety Precautions

- Be careful when riding, always keep your hands on the throttle grips and your feet on the pedals.
- Always pay attention to driving safety, keep a safe distance from other vehicles, avoid pedestrians, and slow down.
- Never carry passengers. Your motorcycle is designed for single-ride use only. Carrying passengers may lead to accidents, causing injuries to you and others.

Protective clothing

Make sure you wear certified motorcycle helmets, goggles and eye-catching protective clothing, and ride carefully according to the weather and road conditions.

■ Helmet

It is certified to safety standards, eye-catching, and sized to fit your head size.

- It must be safe and comfortable and secured with a chin strap.
- It does not obstruct the line of sight of the mask or other certified goggles.

■ Gloves

High wear-resistant all-finger leather glove.

■ Boots or riding shoes

Boots that are strong and slip-resistant and protect the ankle.

■ Clothing

It includes a protective eye-catching long-sleeved shirt suitable for riding and wear-resistant pants (or protective suits).

Warning

- Not wearing a helmet increases the chance of serious injury in an accident.
- Ensure that you always wear a certified helmet and protective clothing.

Riding precautions

Run-in period

Follow these guidelines during the first 500 km of driving to ensure the motorcycle's later reliability and performance.

- Avoid starting with a heavy throttle or rapid accelerating.
- Avoid emergency braking and rapid downshifting.
- Ride carefully.

Brake

Follow the following guidelines:

- Avoid excessive emergency braking and downshifting
 - ▶ Sudden braking will reduce the stability of the motorcycle.
 - ▶ Slow down before turning, or you may slip.
- Be careful when driving on slippery roads
 - ▶ Tyres are easier to slide on slippery surfaces and require longer braking distances.
- Avoid continuous braking
 - ▶ In the long and steep slope down the slope, repeated braking will lead to serious overheating of the brake, affecting the braking effect. You should use the engine brake and use the brake intermittently to slow down.
- The front and rear brakes can be used at the same time to achieve a complete braking effect.

■ Anti-lock brake system (ABS)

This model is equipped with an anti-lock braking system to prevent tire lock-up during emergency braking.

- When the vehicle speed is less than 10 km / h, the anti-lock braking system does not work.
- During braking, after ABS intervention, the brake handle or Foot brake lever may slightly rebound, which is a normal phenomenon.
- Always use the recommended tyres to ensure that the anti-lock braking system works correctly.

■ Engine brake

When you release the throttle, the engine brake will help the motorcycle slow down. If you want to slow down, you can downshift to a low gear. When descending a long and steep slope, the engine should be braked and the brake should be used intermittently to slow down.

■ A humid and rainy environment

In a wet and rainy environment, the road surface will be wet and slippery, and the wet brake will also reduce the braking efficiency. You need to be very careful when braking. If the brake is wet, it can be intermittently repeated during low-speed driving and riding, which helps to dry the brake quickly.

Parking

- Stay on solid, flat ground.
- If you must stop on a slightly inclined or loose ground, make sure to stop the motorcycle and make sure that the motorcycle cannot move or tip over.
- Ensure that high temperature parts do not come into contact with flammable materials.
- Do not touch the engine, muffler, brake and other high temperature parts before cooling.
- To avoid the possibility of theft, be sure to lock the steering handle and remove the key before leaving the unattended motorcycle.

■ Stop the motorcycle with the side support

1. Extinguish engine.
2. Lower side support.
3. Tilt the motorcycle slowly to the left until its weight is concentrated on the side bracket.
4. Turn the steering handle completely to the left.
- ▶ If the steering handle is turned to the right, it will reduce stability and may cause the motorcycle to fall.
5. Turn the ignition switch to the “” (lock) position and remove the key.

Fueling / brake fluid and fuel guide

Follow these guidelines to protect your engine and catalytic converter:

- Only 95# and above unleaded gasoline can be used.
- It is recommended to use high octane gasoline. The use of low octane gasoline will reduce the performance of the engine.
- It is not recommended to use ethanol gasoline, which will reduce the performance of the engine.
- Do not use spoiled or contaminated gasoline, or oil-gasoline blends.
- Prevent dirt and water from entering the tank.
- Since the brake fluid has a certain corrosive effect, be sure to avoid splashing into the eyes, adhering to the skin and avoiding contact with non-metallic materials of the vehicle when adding.

Spare parts and modifications

We strongly recommend that you do not use any accessories other than KOVEMOTO, and do not modify the original design of the motorcycle, which will cause the motorcycle to be unsafe. Unauthorized modifications to your motorcycle will void your warranty service and result in your motorcycle being unable to legally drive on public roads and highways. Before you decide to add accessories to your motorcycle, first determine which modifications are safe and legal.

It is prohibited to attach a trailer or a sidecar to a motorcycle and to modify or install other equipment at the engine installation point. Your motorcycle does not have the design of these accessories, and their use will seriously damage the maneuverability and safety of the motorcycle.

 **Warning**

- Improper accessories or modifications may cause safety accidents, in which you may be seriously injured or even life-threatening.
- Please follow all instructions in the Instruction Manual for accessories and modifications.

Loading guide

- The additional load will affect the maneuverability, braking and stability of the motorcycle. When riding with heavy loads, be sure to maintain a safe speed.
- Please stay within the specified loading limit. The payload of the vehicle is 164kg. Do not overload it.
- Fix all luggage and place it evenly and smoothly near the center of the motorcycle.
- Do not place objects in the headlights or Mufflers.

 **Warning**

- Overload or load inappropriately shall lead to accidents, causing losses of life and injuries.
- Please follow the loading instructions in the Instruction Manual.

Operating instructions

This section contains important information about the operation of the motorcycle, please read this section carefully.

Component location diagram	14
Instruments	16
Switch	27
Ignition switch	29
Start the engine	30
Gear shift	31
Oiling	32

Component location diagram

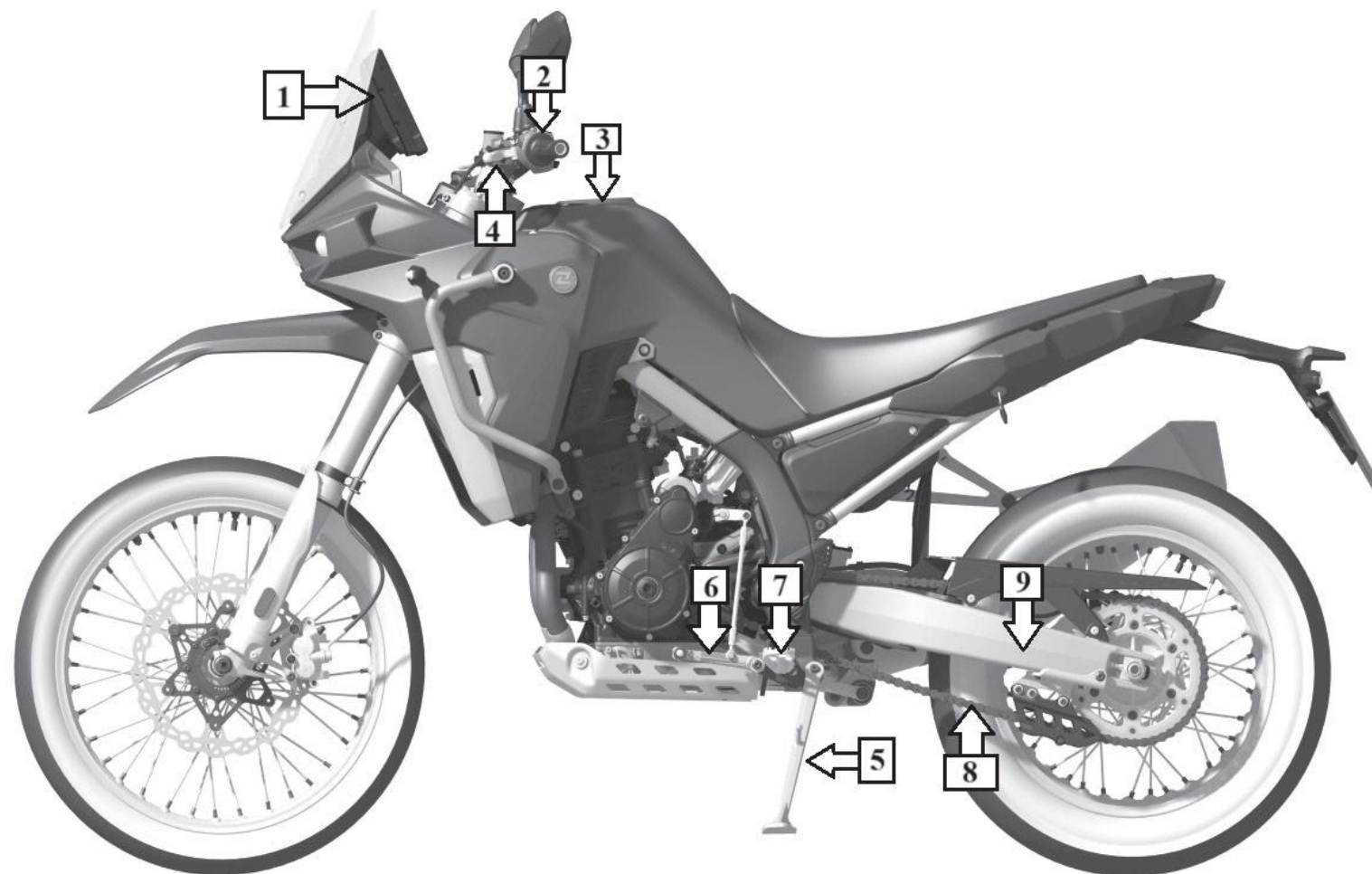

1. Instrument 2. Left combination switch 3. Fuel tank filler cap 4. Clutch lever 5. Side stand 6. Shift lever 7. Rider footrests 8. Chain 9. Link fork

Component location diagram

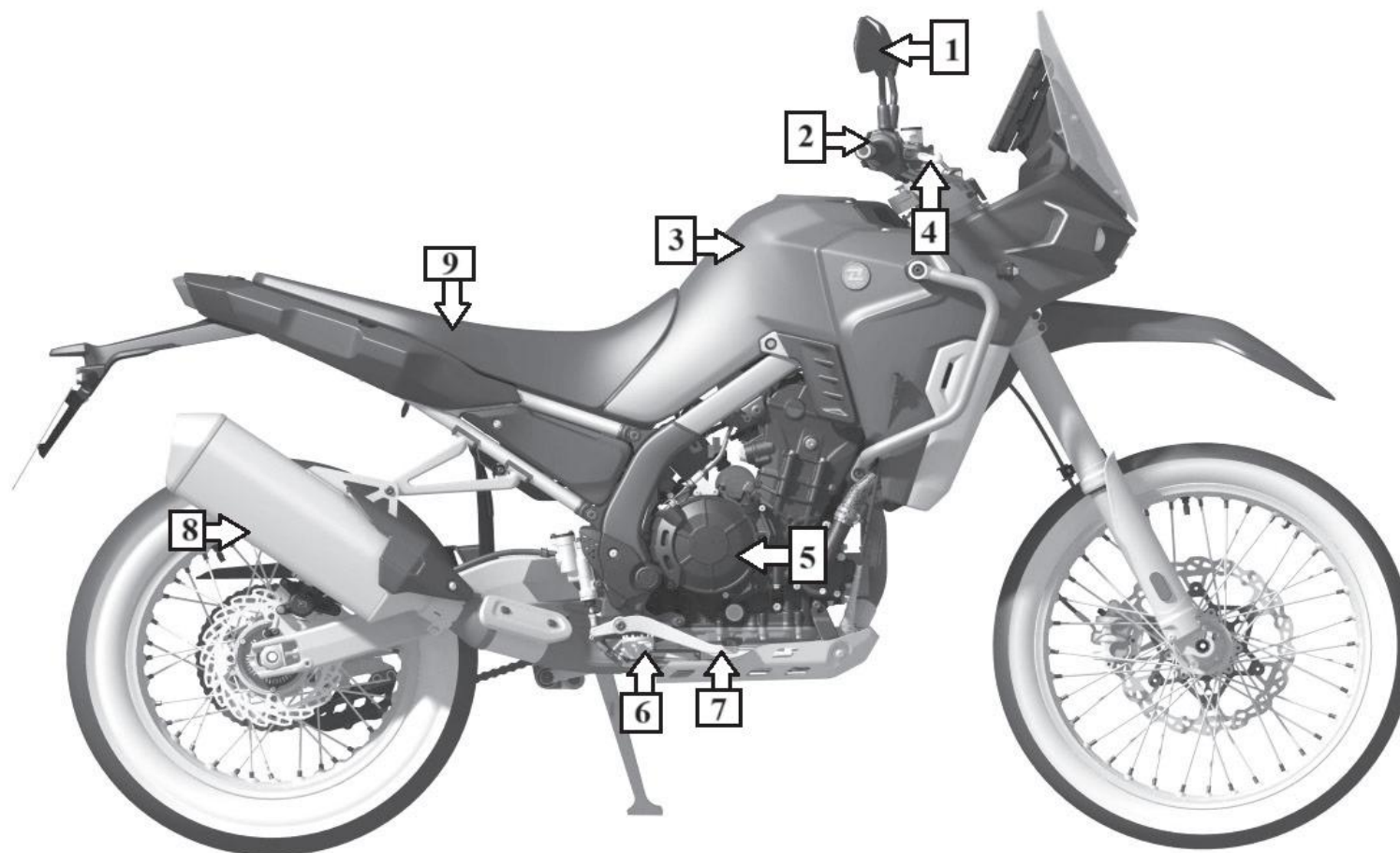

1. Rearview mirror 2. Emergency OFF switch/electric starter button 3. Fuel tank 4. Hand brake lever 5. Engine 6. Rider footrests 7. Foot brake lever 8. Muffler 9. Seat

Instrument - civil version

Instrument main interface



Light-sensitive hole

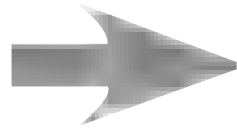

Press and hold the ENT button on the left handlebar switch to switch the right-side interface

Simple navigation interface



Current driving information interface



Mobile projection navigation interface



Display check

When the ignition switch is turned to “○” (ON), the instrument is powered on to play the start-up animation, and then self-test is performed, and all functional modules and symbols are displayed. If the display is missing during self-test, Please go to the special repair shop of KOVEMOTO for repair.

Simple navigation

When using it for the first time, scan the QR code in the interface, and download the mobile APP according to the prompt to connect with the mobile phone. The simple navigation display of the mobile phone shall be set on the mobile phone. For subsequent use, please keep the connection with the APP for subsequent use.

Current riding information

You can view information about ride data settings, and you can reset information display items.

Mobile projection navigation

After the navigation is set in the special APP on the mobile phone, the mobile phone projection navigation display can be realized.

Main interface function description - civil version -1

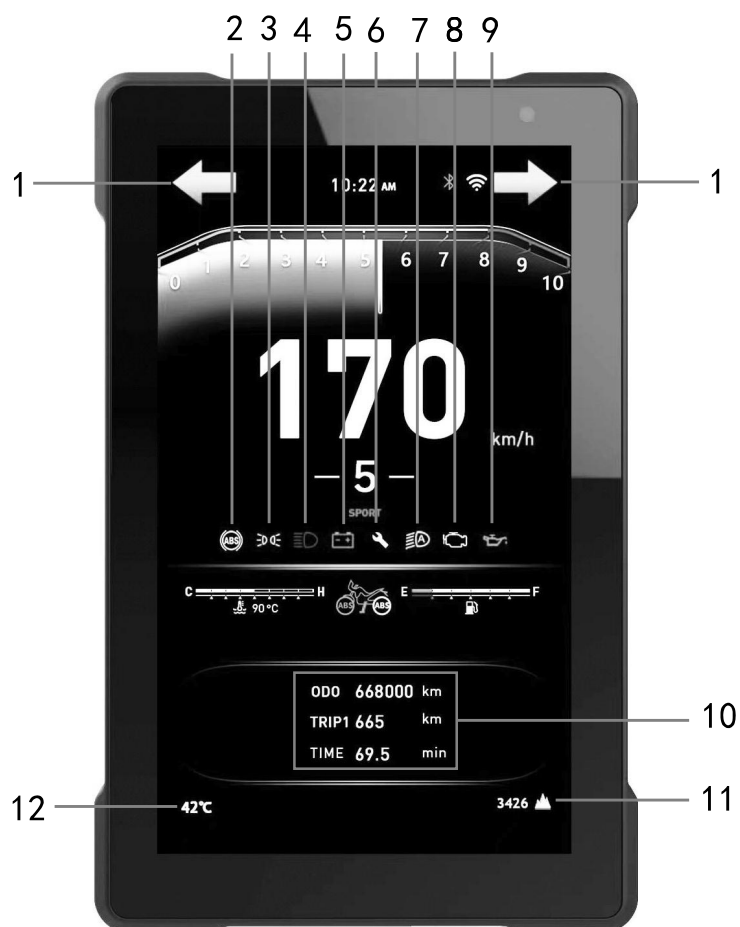

S/N	Name	Functional description
1	Turn indicator light	When the left turn light is on, the left indicator flashes When the right turn light is on, the right indicator flashes
2	ABS malfunction indicator light	When the hazard warning light is turned on, the left and right indicator lamps flash at the same time
3	Position indicator light	①This light is on when a fault occurs ②After the whole vehicle is powered on, this lamp flashes as a normal phenomenon (0.5S on, 0.5S off). When the vehicle speed is > 5km / h, the ABS self-test is extinguished immediately after passing
4	High beam indicator light	This light is on when the position light is on
5	Low voltage indicator	This light is on when the battery voltage is too low
6	Service indicator light	When the motorcycle reaches the maintenance setting condition, this lamp is on
7	Dipped beam indicator light	When the button headlight, automatic headlight and headlight are always on, this light is on
8	Electronic injection malfunction indicator light	When the electronic injection system fails, this lamp lights up (after the engine is powered on and started normally, the failure lamp goes out as a normal phenomenon)
9	Oil pressure indicator	When the oil pressure is insufficient, this light is on
10	Mileage display	Display the total mileage, sub-total mileage and riding time of the vehicle
11	Altitude display	Display altitude (need to be interconnected with mobile phone)
12	Temperature display	Display the ambient temperature (need to be interconnected with the mobile phone)

Main interface function description - civil version -2



S/N	Name	Functional description
13	Time display	Time display
14	Bluetooth display	This light is on when the Bluetooth connection is successful
15	WIFI display	This light is on when the connection with WIFI is successful
16	Speedometer	Display the current ride speed
17	Gear indication	Display the current gear
18	Oil level display	The following oil level display is for reference only: 1st bar: oil gauge ≤ 3.2 L (when there is only one bar of oil level left, please add fuel as soon as possible) 2nd bar: 3.2-5.3 L 3rd bar: 5.3-7.3 L 4th bar: 7.3-9.35 L 5th bar: 9.35-11.1 L 6th bar: fuel gauge > 11.1 L (due to the limited internal structure of the oil tank, the last bar contains more oil than other single bars)
19	ABS status display	①Front and rear wheels show a white profile: Front and rear wheel ABS open ②The rear wheel shows yellow fill: Rear wheel ABS off ③Front and rear wheels show a yellow fill: Front and rear wheel ABS off
20	Water temperature display	①When the water temperature indicator block displays red and lights up the “water temperature alarm lamp”, it means that the water temperature is too high. In the case of ensuring safety, stop for inspection, and continue driving after the water temperature drops ②When the water temperature data is abnormal, all water temperature color blocks and icons will flash together (when the flameout switch is off, the flashing is a normal phenomenon)
21	Tachometer	Display engine rotating speed

Menu description - civil version - 1

Level 1 menu	Level 2 menu	Level 3 menu	Description
Headlight	/	/	Press ENT to display the headlight on/off
Riding mode	SPORT	/	Set the engine power output mode (SPORT: sport mode, ECO: economy mode), and the riding mode has a memory function
	ECO	/	
ABS switch	Turn on the front and rear wheels	/	Set the ABS working status, and the current ABS working status is displayed through the instrument icon
	Turn off the rear wheel	/	
	Turn off the front and rear wheels	/	
More setting	Mobile phone connection	Bluetooth connection	Set the mobile phone for Bluetooth connection available (in order to ensure normal connection, the mobile phone-specific APP needs to enable relevant permissions according to the prompts)
		WIFI connection	Set the mobile phone for WIFI connection available (when WIFI is connected, do not choose to use the instrument WIFI to surf the Internet, otherwise it will affect the mobile phone surfing function)
		Reset Bluetooth	Reset the Bluetooth connection of the mobile phone
		Reset WIFI	Reset the WIFI connection of the mobile phone
	Music	/	After the mobile phone is connected, users can switch/pause the music through the instrument
	Picture display	Display mode	Users can choose the day and night UI mode that has been used according to their preferences, and the factory default is automatic
		Display brightness	Users can choose the screen brightness level that has been used according to their own preferences, and the factory default is automatic
	Headlight mode	Automatic headlights	When this function is selected, the instrument will automatically control the brightness of the headlights according to the ambient brightness
		The headlights are always on	When this function is selected, the headlights will be on in the constant ON mode after the engine is started
		Manual headlight	When this function is selected, the headlights will be turned on in manual mode after the engine is started
	Time setting	/	The user can manually set the instrument time

Menu description - civil version - 2

Level 1 menu	Level 2 menu	Level 3 menu	Description
More setting	Ride data	Average vehicle speed	When the average vehicle speed = 0, the average vehicle speed displays “-”
		Average fuel consumption	The average fuel consumption calculation result is affected by many factors such as vehicle working conditions and ride habits. The display data is for reference only.
		Top speed	Display of maximum speed during this riding
	Language	Chinese	Setting the Chinese menu
		English	Setting the English menu
	Maintenance setting	/	①Setting and clearing of maintenance mileage or time: The first guarantee is 500km or one year, the second guarantee is 1500km or one year. This default parameter cannot be modified, and the user can set the maintenance reminder cycle according to the actual situation ②Maintenance prompt clearing method: Long press ENT key under the maintenance service interface to pop up the clearing dialog box, and operate according to the prompt content
	Unit display	Speed	Switchable vehicle speed unit between km/h and MPH
		Time format	Switchable between 12-hour and 24-hour systems
		Temperature	Switchable temperature units between °C and F
	Motorcycle information	ECU current fault	Display ECU current fault information
		ABS current fault	Display ABS current fault information
	Equipment information	/	Display MCU, SOC, mobile phone interconnection software version and UUID

Instrument - competitive version

Instrument main interface



Light-sensitive hole



Press and hold the ENT button on the left handlebar switch to switch the right-side interface

Simple navigation interface



Current driving information interface



Mobile projection navigation interface



Display check

When the ignition switch is turned to “○” (ON), the instrument is powered on to play the start-up animation, and then self-test is performed, and all functional modules and symbols are displayed. If the display is missing during self-test, Please go to the special repair shop of KOVEMOTO for repair.

Simple navigation

When using it for the first time, scan the QR code in the interface, and download the mobile APP according to the prompt to connect with the mobile phone. The simple navigation display of the mobile phone shall be set on the mobile phone. For subsequent use, please keep the connection with the APP for subsequent use.

Current riding information

You can view information about ride data settings, and you can reset information display items.

Mobile projection navigation

After the navigation is set in the special APP on the mobile phone, the mobile phone projection navigation display can be realized.

Main interface function description - competitive version -1

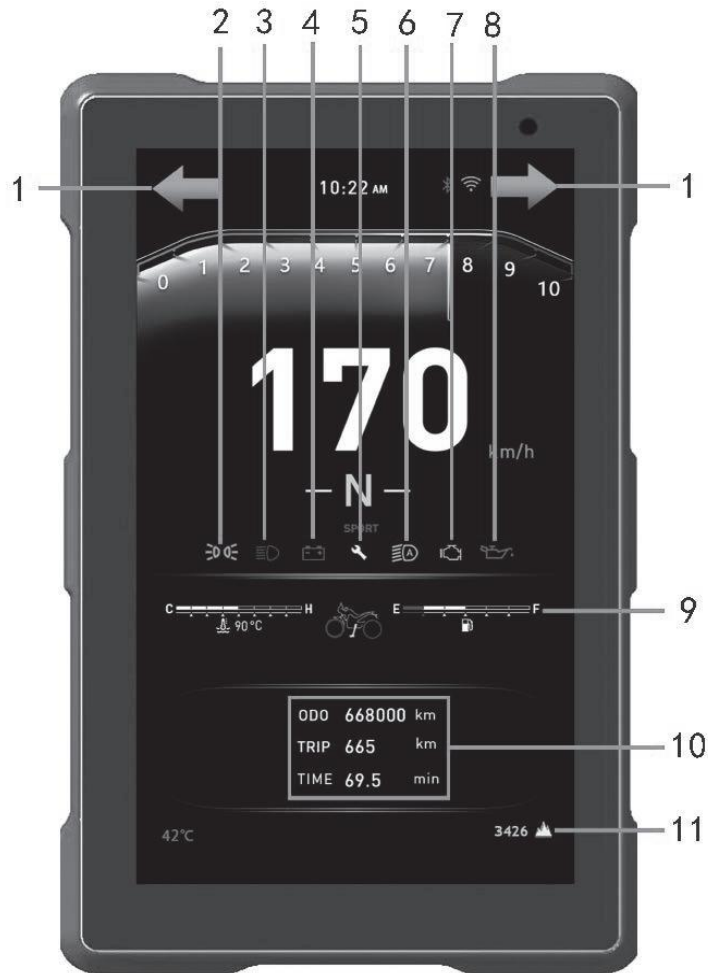

S/N	Name	Functional description
1	Turn indicator light	When the left turn light is on, the left indicator flashes When the right turn light is on, the right indicator flashes When the hazard warning light is turned on, the left and right indicator lamps flash at the same time
2	Position indicator light	This light is on when the position light is on
3	High beam indicator light	This light is on when the high beam is switched on
4	Low voltage indicator	This light is on when the battery voltage is too low
5	Service indicator light	When the motorcycle reaches the maintenance setting condition, this lamp is on
6	Dipped beam indicator light	When the button headlight, automatic headlight and headlight are always on, this light is on
7	Electronic injection malfunction indicator light	When the electronic injection system fails, this lamp lights up (after the engine is powered on and started normally, the failure lamp goes out as a normal phenomenon)
8	Oil pressure indicator	When the oil pressure is insufficient, this light is on
9	Oil level display	The following oil level display is for reference only: 1st bar: oil gauge \leq 3.2 L (when there is only one bar of oil level left, please add fuel as soon as possible) 2nd bar: 3.2-5.3 L 3rd bar: 5.3-7.3 L 4th bar: 7.3-9.35 L 5th bar: 9.35-11.1 L 6th bar: fuel gauge > 11.1 L (due to the limited internal structure of the oil tank, the last bar contains more oil than other single bars)
10	Mileage display	Display the total mileage, sub-total mileage and riding time of the vehicle
11	Altitude display	Display altitude (need to be interconnected with mobile phone)

**Main interface function description-
competitive version-2**



S/N	Name	Functional description
12	Time display	Time display
13	Bluetooth display	This light is on when the Bluetooth connection is successful
14	WIFI display	This light is on when the connection with WIFI is successful
15	Speedometer	Display the current speed
16	Gear indication	Display the current gear
17	Temperature display	Display the ambient temperature (need to be interconnected with the mobile phone)
18	Water temperature display	①When the water temperature indicator block is red and the "water temperature warning light" is on, it indicates that the water temperature is too high. If safety is ensured, stop the vehicle for inspection and continue driving after the water temperature drops. ②When the water temperature data malfunction, all water temperature color blocks and icons will flash at the same time (when the cut-off switch is turned off, the flashing is normal)
19	Tachometer	Display engine rotating speed

Menu description - competitive version - 1

Level 1 menu	Level 2 menu	Level 3 menu	Description
Headlight	/	/	Press ENT to display the headlight on/off
Riding mode	SPORT	/	Set the engine power output mode (SPORT: sport mode, ECO: economy mode), and the riding mode has a memory function
	ECO	/	
More setting	Mobile phone connection	Bluetooth connection	Set the mobile phone for Bluetooth connection available (in order to ensure normal connection, the mobile phone-specific APP needs to enable relevant permissions according to the prompts)
		WIFI connection	Set the mobile phone for WIFI connection available (when WIFI is connected, do not choose to use the instrument WIFI to surf the Internet, otherwise it will affect the mobile phone surfing function)
		Reset Bluetooth	Reset the WIFI connection of the mobile phone
		Reset WIFI	Reset the WIFI connection of the mobile phone
	Music	/	After the mobile phone is connected, users can switch/pause the music through the instrument
	Picture display	Display mode	Users can choose the day and night UI mode that has been used according to their preferences, and the factory default is automatic
		Display brightness	Users can choose the screen brightness level that has been used according to their preferences, and the factory default is automatic
	Headlight mode	Automatic headlights	When this function is selected, the instrument will automatically control the brightness of the headlights according to the ambient brightness
		The headlights are always on	When this function is selected, the headlights will be on in the constant ON mode after the engine is started
		Manual headlight	When this function is selected, the headlights will be turned on in manual mode after the engine is started
	Time setting	/	The user can manually set the instrument time
	Ride data	Average vehicle speed	When the average vehicle speed = 0, the average vehicle speed displays " _ "
		Average fuel consumption	The average fuel consumption calculation result is affected by many factors such as vehicle working conditions and ride habits. The display data is for reference only.
Top speed		Display of maximum speed during this riding	

Menu description - competitive version - 2

Level 1 menu	Level 2 menu	Level 3 menu	Description
More setting	Language	Chinese	Setting the Chinese menu
		English	Setting the English menu
	Maintenance setting	/	①Setting and clearing of maintenance mileage or time: The first guarantee is 500km or one year, the second guarantee is 1500km or one year. This default parameter cannot be modified, and the user can set the maintenance reminder cycle according to the actual situation ②Maintenance prompt clearing method: Long press ENT key under the maintenance service interface to pop up the clearing dialog box, and operate according to the prompt content
	Unit display	Speed	Switchable vehicle speed unit between km/h and MPH
		Time format	Switchable between 12-hour and 24-hour systems
		Temperature	Switchable temperature units between °C and F
	Motorcycle information	ECU current fault	Display ECU current fault information
	Equipment information	/	Display MCU, SOC, mobile phone interconnection software version and UUID

The instrument functions are as follows:

Instrument button:

Short press the SET key to enter the menu setting; long press the SET key to enter the display interface setting. Press the up and down keys to conduct page turning.

Information viewing:

When the mobile phone is connected with Bluetooth, the message display panel will reflect the information pushed by the mobile phone. Press the SET key to view the details, and press the BACK key to clear it.

Function setting:

Press the SET key to enter the instrument menu. The riding mode (SPORT or ECO), ABS mode (for civil version only) and instrument brightness can be set according to the human-machine dialogue menu. Ride data, automatic headlights (on or off), time, language and other functions.

Instrument and mobile phone interconnection:

1. The navigation function, information push function, weather function, automatic time function, altitude display and other functions in the TFT instrument can only be realized after interconnection with the mobile phone installed with the relevant APP.

2. Mobile APP installation steps: ① Press and hold the SET key to enter the display interface settings; ② Select "Simple navigation" or "Mobile projection navigation"; ③ Scan the QR code in the interface according to the mobile phone system, and follow the prompts to download and install the APP; ④ Turn on the mobile phone Bluetooth and WIFI to realize interconnection with the instrument (in order to make you have a better use experience, please refer to the relevant help guide when using the mobile APP).



3. When the instrument needs to be disconnected from the mobile phone, enter the mobile phone setting menu and select Disconnect Bluetooth/ Disconnect WIFI.

Switch

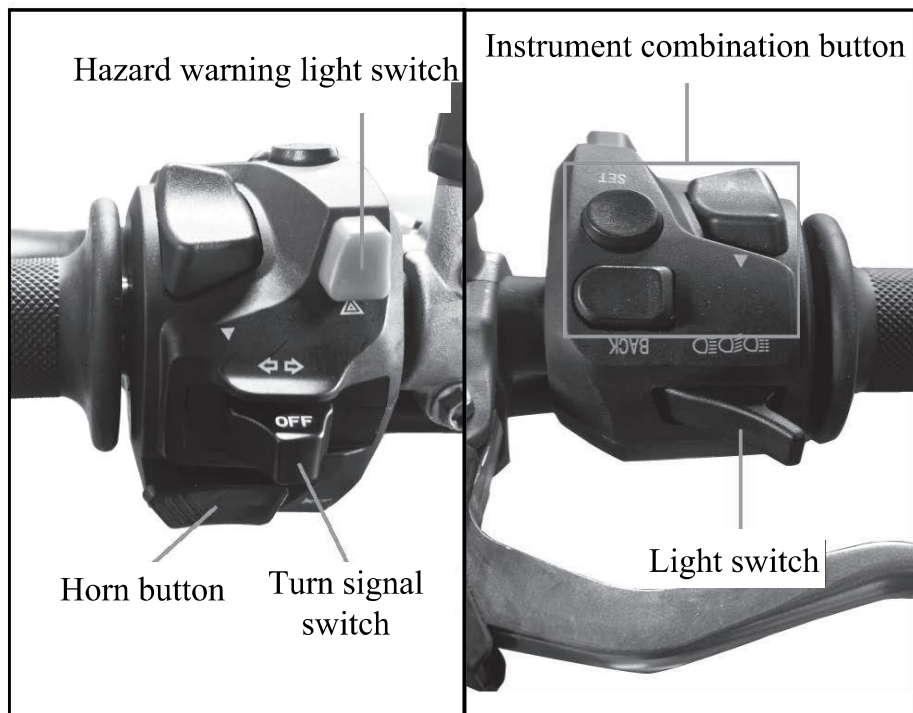
Left combination switch



Light switch: The light switch is located on the back of the handle switch

-  Turn on the pass light
-  Turn on the high beam
-  Turn on the dipped beam

Menu switch: This combination button is used to set the functions of the instrument.

  : Select to switch up and down

BACK: Back button

SET: Set instrument function button

Hazard warning light switch:

 After the emergency button is pressed, the left and right turn signal lamps flash at the same time.

Turn signal switch:

 Turn on the left turn signal: toggle the switch to the left, the left turn signal flashes, and the turn signal switch returns to its original position after operation.

 Turn on the right turn signal: toggle the switch to the right, the right turn signal flashes, and the turn signal switch returns to its original position after operation.

OFF Turn off the turn signal: When the turn signal switch is in the middle position, press this button to turn off the turn signal.

Right combination switch

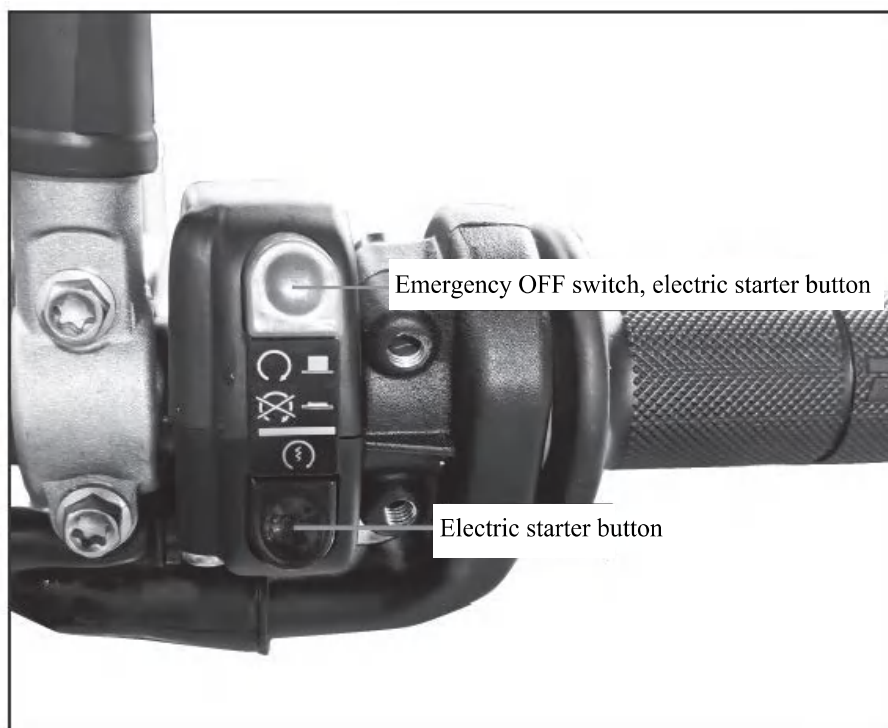

Emergency OFF switch:



When the switch is in the “” (run) position, the engine can be started;

When the switch is in the “” (stop) position, the engine cannot be started.

► In case of emergency, switch to the “” (stop) position to extinguish the engine.

Electric starter button:

When the OFF switch is set to “” position:

- ① If the engine is in neutral, press the “” button to start the engine.
- ② If the engine is not in neutral, users should retract the side stand and squeeze the clutch handle, then press the “” button to start the engine.

● When the headlights are illuminated by the automatic headlight function, the light switch cannot turn off the headlights at this time.

Ignition and steering lock

When the key is in the "❌" position, turn the direction handle to the leftmost, press the key, and rotate it counterclockwise to the "🔒" position, and the direction can be locked; if users need to unlock, rotate the key clockwise.



Location	Function	Note
❌	Use when parking (whole motorcycle power off)	The key can be removed
🔄	Used when starting or driving	The key cannot be removed
🔒	Use when locking the vehicle (the vehicle is powered off and the direction is locked)	The key can be removed



⚠ Warning

- When parking (including long-term parking), the ignition switch must be in the “❌” or “🔒” position to ensure the safety of the motorcycle and prevent the battery from losing power.
- When the steering mechanism is locked, do not push the motorcycle, otherwise it will lose its balance.

Start the engine

Whether the engine is hot or cold, please follow the instructions below to start the engine.



1. Turn the ignition switch to the “  ” (ON) position.
2. Verify that the engine shutoff switch is in the “  ” (Run) position.
3. Shift the gear to neutral to start the engine. If the transmission is in the upper gear mode, squeeze the clutch handle.
4. Press the start button with the accelerator fully closed.

If the engine is not started:

If the engine does not start within 3 seconds, wait 10 seconds before repeating step 4 above.

- If the engine starts and the idle speed is unstable, the throttle should be slightly increased.
- Prolonged high-speed idling and rotation can damage the engine and exhaust system.
- Hot fill or high idle speed for more than 5 minutes may cause discoloration of the exhaust pipe.
- If the throttle is fully open, the engine will not start.

Gear shift

Your motorcycle has 6 forward gears and adopts 1 down 5 up shift mode.

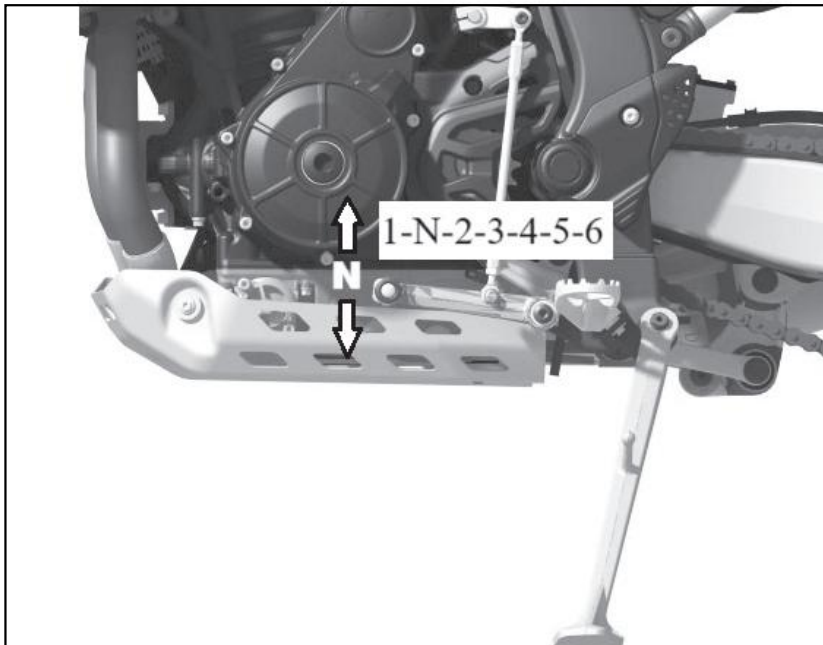

Method of shift:

Warm up the engine for normal operation.

1. When the engine is idling, disengage the clutch and press down on the shift pedal to move the transmission into the low (1st) gear position.
2. Gradually increase the engine speed and slowly release the clutch handle. These two actions can be coordinated to ensure a natural start.
3. When the motorcycle reaches the balanced driving state, reduce the engine speed and then disengage the clutch, hook up the shift pedal to enter the second gear, and so on.

Precautions during driving:

1. Avoid unnecessary engine idling, and do not allow the engine to idle at high speed, otherwise it will seriously damage the parts.
2. When the clutch is running in a semi-separated state, the clutch plate will wear quickly.
3. If you feel that the engine horsepower is insufficient when climbing, you should switch to low gear in time.
4. In driving, especially downhill and high-speed driving, it is not allowed to use the front brake or neutral coasting alone, and it is not allowed to drive off the handle.
5. When parking, you should put away the small throttle, cut off the clutch at the same time, and then brake.

Fill up with oil

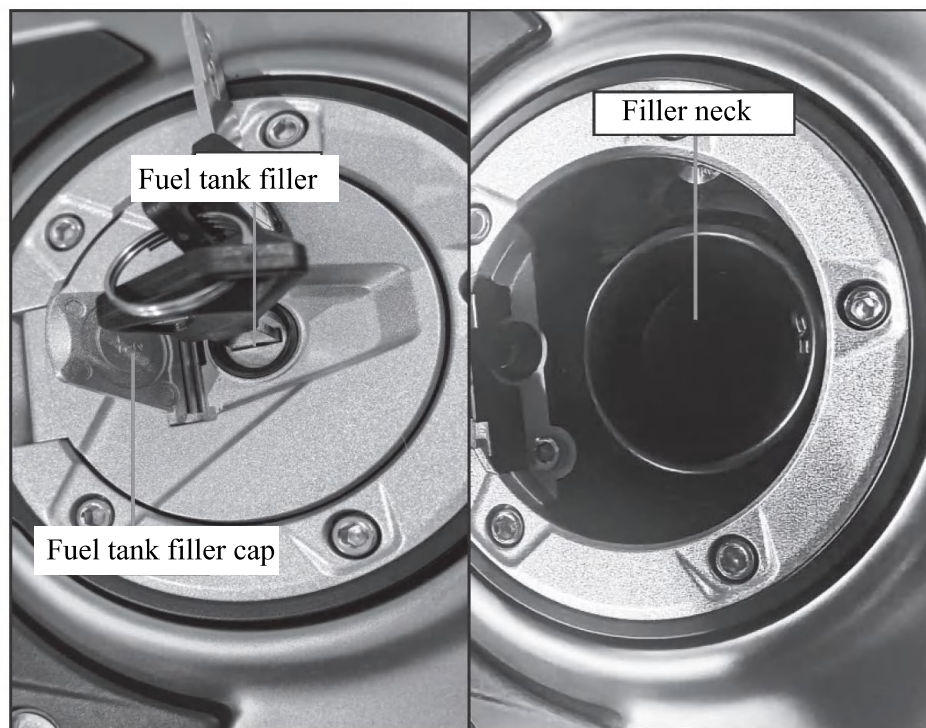

Open the fuel tank cover:

Turn over the lock cover, insert the ignition key, and turn clockwise to open the fuel tank cover.

Close the tank cap:

1. After refueling, press the fuel tank cover down until it locks.
2. Remove the key and close the fuel tank lock cap. If the tank cap is not locked in place, the key cannot be pulled out.

When filling with fuel:

After the side stand is stopped, open the fuel tank cap and conduct filling. Avoid overfilling the fuel. Pay attention to the oil level change during filling. It is recommended that the filling gauge shall not exceed 90% of the total capacity of the fuel tank (to avoid expansion of the fuel due to heat). The capacity of the fuel tank is 20 L. It is recommended to use 95# or above unleaded gasoline. After the fuel is filled, close and lock the fuel tank cap.

Notes:

Regularly check whether the drain pipe of the fuel tank lock is unobstructed to prevent the pipeline from being plugged and unable to drain, or too much water enters the fuel tank.

Warning

- When refueling, please do it outdoors. Be sure to extinguish the engine, away from heat sources, sparks or open flames. If there is a splash, please immediately wipe clean.

Maintenance

Please read “Maintenance” and “Maintenance Specifications” carefully before preparing for maintenance. For maintenance data, please refer to “Technical Parameters”.

Maintenance	34
Maintenance schedule	35
Check list of torque cycles at off-weight position	36
Maintenance specifications	37
Replacement part	38
Remove and install body component	45
Engine oil	47
Coolant	50
Brakes	52
Side support	54
Drive chain	55
Clutch	57
Throttle	58
Front shock absorber adjustment	59
Rear spring strut adjustment	62
Directional damper adjustment	65
Headlight	68

Maintenance

The importance of maintenance

It is important to keep your motorcycle in good condition of maintenance, which is essential for your safety, as well as protecting your property, getting the best performance, preventing breakdowns and reducing air pollution.

Maintenance is an important responsibility of the motorcycle owner to ensure that the inspection is carried out before each ride and that the periodic inspection is carried out as described in the maintenance cycle table.

Please follow the following guidelines for maintenance:

- Turn off the engine and remove the key.
- Park the motorcycle on a firm and flat ground with side brackets, or support it with maintenance brackets.
- Please wait for the engine, muffler, brake and other high temperature components to cool before starting the operation, otherwise it may cause burns.
- Please start the engine under the specified conditions and in a well-ventilated environment.

Warning

- Failure to carry out normal maintenance before riding or failure to correct the fault can lead to serious injury or fatal accidents.
- Please follow the inspection, maintenance recommendations and maintenance schedule provided in the instruction manual.

Maintenance schedule

The motorcycle should be maintained within the specified time. In order to ensure safety, it can only be repaired by a special repair shop of KOVEMOTO. The symbols in the table have the following meanings:

I: Carry out inspection, cleaning and adjustment R: Change A: Adjust L: Lubrication

Maintenance times Maintenance items		Maintenance cycle					
		1000~1500Km	Per 5000Km	Per 10000Km	Per 20000Km	Every year	Every 2 year
※	Fuel system oil circuit	I	I	I	I	I	I
	Fuel filter	I/R	I/R	I/R	R	R	R
※※	Valve clearance				I		
※	Engine oil	R	R	R	R	R	R
※	Oil filter element	R	R	R	R	R	R
※	Timing chain tension	A	A	A	A	A	A
	Transmission chain		I&L	I&L	I&L	I&L	I&L
	Brake shoe worn	I	I	I	I	I	I
※	Brake system	I	I	I	I	I	I
※	Clutch	I	I	I	I	I	I
※	Fasteners	I	I	I	I	I	I
※	Directional bearing	I	I	I	I	I	I
※※	Deep groove ball bearing with buffer	I	I	I	I	I	I
※	Front and rear wheel bearings	I	I	I	I	I	I
	Battery	I	I	I	I	I	I
※	Fuel system oil circuit/ filter			R	R	R	R
※	Spark plug			I	I	I	I
※	Plain fork bearing				I&L	I&L	I&L
※	Brake fluid					R	R
	Coolant	I	I	I	I	I	R

※ This item is maintained by the personnel of the special repair shop of KOVEMOTO. If the user has special tools, maintenance accessories and maintenance capabilities, they can also repair themselves, and the maintenance knowledge can refer to this Instruction Manual.

※※ In order to ensure safety, the project can only be repaired by the personnel of the special repair shop of KOVEMOTO.

Pay special attention (when riding in dusty or polluted areas):

1. Clean the air filter element every day.
2. Clean the shock absorber every day

Check list of torque cycles at off-weight position

S/N	Name of fastening location	Recommended test cycle
1	Front and rear axle, flat fork shaft fastening	
2	Shock absorption and fastening before upper and lower connecting plates are hugged tightly	
3	The upper connecting plate is fastened to the steering column	
4	Fastening of steering column 8-slot nut	
5	Fastening of the lower card holder with the steering hand	A torque check is required for each maintenance cycle.
6	Fastening of installation of small engine sprocket	
7	Fastening of engine suspension	
8	Fastening of rear shock absorber	
9	Fastening of cradle bolts	
10	The front section of the muffler is connected with the engine	
11	Fastening of front and rear brake calipers	
12	Fastening of rear brake pump	
13	Fastening of shift lever and adjusting lever end bearing	
14	Fastening of brake pedal and adjusting rod end bearing	
15	Fastening of all-vehicle brake oil pipe	When cleaning the oil circuit, carry out maintenance according to the required torque.
16	Fuel rail fastening	
17	Fuel pump fastening	
18	Fastening of front and rear brake discs	When checking or replacing each maintenance cycle, carry out maintenance according to the required torque and gluing method.
19	ABS ring gear	

Note: The torque cycle inspection items and torque standards not stated in this instruction manual shall be implemented in accordance with our *Maintenance Manual*.

Maintenance specifications

In order to ensure safety, it is your responsibility to conduct a pre-ride inspection and ensure that any problems you find have been resolved. A pre-ride inspection is required.

Inspection items	Inspection contents
Steering hand	Flexible rotation, no play and loose
Brake system	Check its operating condition, check the front and rear brake fluid level and brake pad wear
Fuel level	Enough oil for the planned driving distance (please refuel if necessary)
Throttle	Check that it opens smoothly and closes completely in each steering position
Clutch	Check its operation and adjust the free travel if necessary
Wheels and tyres	Check the use condition and tire pressure, and supplement the air pressure if necessary
Drive chain	Check its use and sag, adjust and lubricate if necessary
Lighting and horn	Check the lighting system and horn for good performance
Oil level	Add engine oil if necessary and check for leaks
Instrument indication	Check whether the indicators on the instrument display normally

Replace part

Battery

Check and replace the battery

1. Before installing the battery, if the electrode is dirty, please wipe it clean and then install it, otherwise the function may fail due to poor contact.
2. In the process of use, if the battery is deformed, abnormal heat, smoke and other abnormal phenomena, please immediately stop using, and timely handed over to the special repair shop of KOVEMOTO for inspection.
3. If the battery is placed in a high temperature and humid environment for a long time, functional failure and short life may occur. Before using it again, please ensure that the battery appearance and function are normal before installation and use.
4. If the entire motorcycle can not start, please check whether the battery is normal, such as battery damage, please replace it in time.
5. When installing the battery, be sure to lock the battery pole bolt

IF the batty is not ued for a long time, please pay attention to the folloing conditionss:

- To prevent the occurrence of excessive discharge, the battery should be charged every two months.
- When the battery is not used, it should be placed in a cool and dry environment to prevent short circuit of the positive and negative electrodes of the battery.

- Improper handling of batteries may cause harm to the environment and human health, please dispose of waste batteries in accordance with local environmental regulations.
- The installation of complete vehicle electrical appliances may lead to a loss of battery power and even cause electrical system failure.

Fuse

Fuses protect the electrical circuit of your motorcycle. If some electrical parts of your motorcycle stop working, check and replace the blown fuses.

Check and replace fuses

Turn the ignition switch to the “” (OFF) position to take out and check the fuse. If the fuse is blown, please replace it with a fuse of the same specification, and refer to “Technical Parameters” for fuse specification.

If the fuse is often blown, there may be hidden problems in the electrical equipment, please go to the special repair shop of KOVEMOTO.

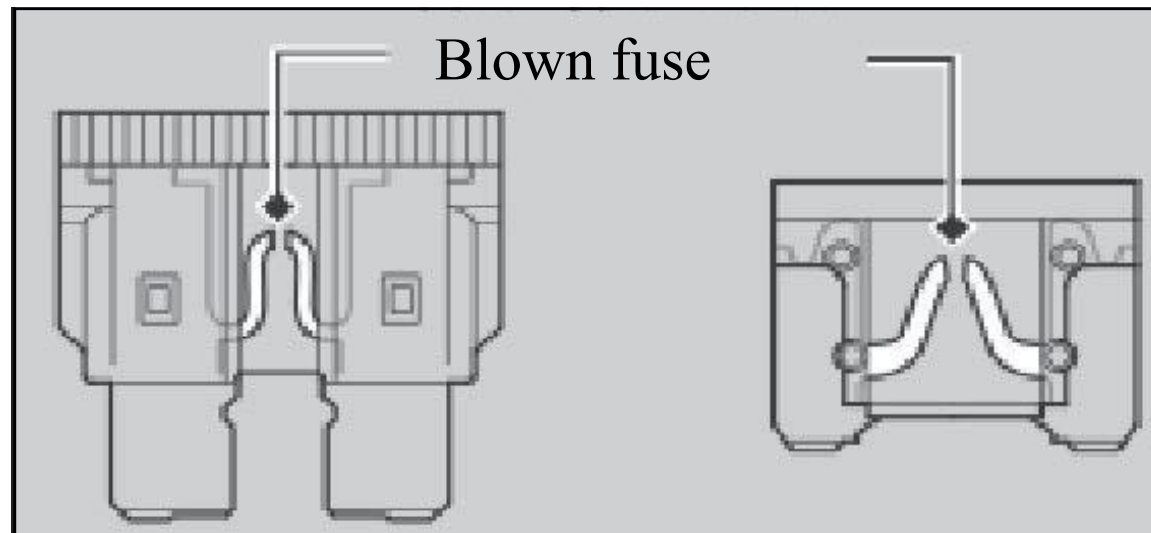

- The fuse needs to be replaced in an equal amount, and replacing a fuse with a higher rating will increase the chance of damage to the electrical system and the risk of burning the motorcycle.
- Installing non-KOVEMOTO locomotive electrical accessories will overload the electrical system, causing the battery to discharge, and even destroy the system

Engine oil

The consumption of engine oil and the decline in oil quality will vary depending on the driving conditions and the use time. The higher the operating speed, the faster the oil consumption rate. When running at high speed or high speed for a long time, the oil change cycle should be shortened, and the engine oil level should be checked frequently. If necessary, add the recommended engine oil.

When used at extreme temperatures, the oil quality drops faster, and the dirty or long-used oil should be replaced as soon as possible.

Select engine oil

Maintenance oil should be selected with an API classification of SN grade or higher. And the selected viscosity grade is 10W50.

Brake fluid

Do not add or replace brake fluid unless in an emergency.

Only use the brake fluid newly removed from the sealed container. If you add the brake fluid, please go to the special repair shop of KOVEMOTO to check the brake system as soon as possible.

Coolant

Use only the original KOVEMOTO premixed coolant that is not diluted with water. The original KOVEMOTO premixed coolant can prevent corrosion and overheating, please pay attention to the coolant capacity. If the liquid level is lower than the lower limit, please add it in time. The freezing point of coolant is -40°C and the boiling point is 110°C .

- Brake fluid can damage plastic and paint surfaces. If it spills, wipe off immediately and clean thoroughly.
- Recommended brake fluid: DOT4 brake fluid or equivalent.
- Since ordinary tap water or mineral water can cause corrosion, use a special coolant for non-aluminum engines.

Drive chain

The drive chain must be checked regularly and lubricated. If you often drive in poor road conditions, high speed or repeated speed increases, you need to check the chain more frequently.

If the drive chain is not running smoothly, it makes abnormal noise, there is a damaged roller or a loose bolt, and the oil seal is lost or bent, please check the chain with the special repair shop of KOVEMOTO.

Simultaneously check the driving sprocket and the driven sprocket. If any one has worn or bad teeth, please go to the special repair shop of KOVEMOTO for replacement.

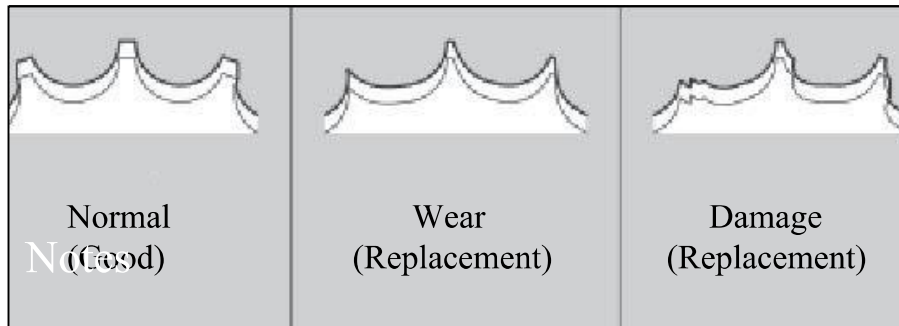

Cleaning and lubricating

After checking the sag, turn the rear wheel and clean the chain and sprocket at the same time. Use dry cloth, oil seal chain special cleaning agent or neutral detergent. If the chain is dirty, use a soft brush, clean and dry and lubricate with the recommended lubricant.

Do not use non-oil seal chain-specific steam cleaners, high-pressure cleaners, wire brushes, volatile solvents such as gasoline and benzene, scrubbers, chain cleaners and lubricants, otherwise they may damage the chain oil seal.

Avoid getting lubricating oil on the brakes or tires, and avoid using excessive lubricating oil to avoid splashing on clothes or motorcycles.

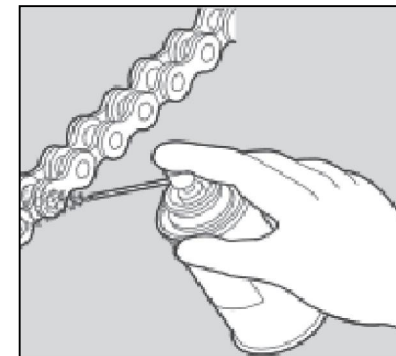

- The use of a new drive chain on a worn sprocket will speed up chain wear, and the drive chain and sprocket should be replaced at the same time.
- Recommended lubricating oil: Special lubricating oil for chain oil seal.

Tyres (check / replace)

Tyre size

Front: Cover tire: 90/90-21M/C 54S Inner tube: 2.75/3.00-21 Pad belt: Liner belt 21×30mm

tyres: 140/60R17 Cover tire: 140/80-18M/C 70S Inner tube: 4.50/4.75/5.10-18 Pad belt: Liner belt 18×30mm

Abnormal wear check

Check the contact surface of the tire for signs of abnormal wear.

Check tread depth

Wear indication Check the tread wear indication mark. If the wear reaches the indication mark, position marking replace the tire immediately.

Check tire pressure

When you feel that the tire pressure is insufficient, use a barometer to measure the tire pressure, and check the tire pressure when the tire is cold at least once a month. Ensure that the valve core cover is tight and replace it with a new one if necessary.

The tire pressure standard value is: Front tire: 200KPa; rear tire: 225KPa

Damage check

Inspect the tire for cuts, cracks, exposed fabric, tire threads, nails, or other foreign matter embedded in the side tread of the tire, and check the tire sidewall for any abnormal bulging or expansion.

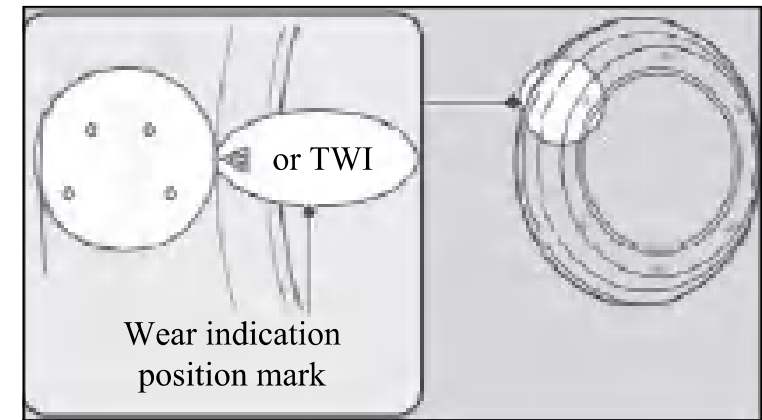

Whenever changing tyres, follow the following guidelines:

- Use recommended tyres or equivalent products of the same size, construction, speed class and load capacity.

Warning

- The use of excessively worn or improperly inflated tyres can lead to accidents and serious casualties. Please follow the relevant tyre inflation and maintenance guidelines in the instruction manual.
- Installing an unsuitable tire can affect handling and stability, and lead to accidents and even endanger life.
- Always use tyres of the size and type recommended in this Instruction Manual.

Air cleaner

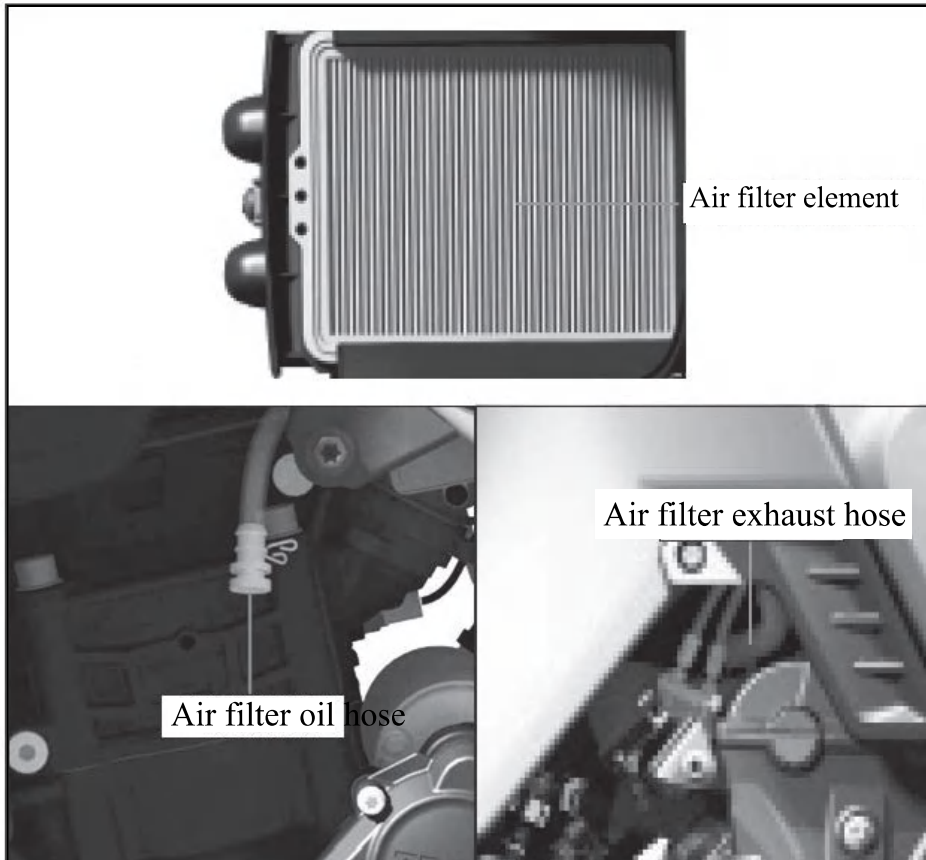

This motorcycle is equipped with an air filter element made of paper, please do not maintain it by yourself. It should be cleaned or replaced by a special repair shop of KOVEMOTO.

The oil collection tube of the air filter is located on the lower left side of the air filter. Check whether there is water or oil in the oil collecting tube every 1 month, especially check promptly after washing the motorcycle or exposure to heavy rain. If any, remove the air filter oil collecting tube to conduct discharge, and reinstall it after draining completely.

The air filter exhaust tube is located on the upper right side of the engine, which is used to discharge the pressure in the engine and prevent water or other substances from entering the engine. When the engine power is insufficient, check whether there is blockage in the air filter exhaust tube in time. If any, remove the tube to conduct the discharge, and reinstall the tube after after discharging completely.

Remove and install body component

Battery

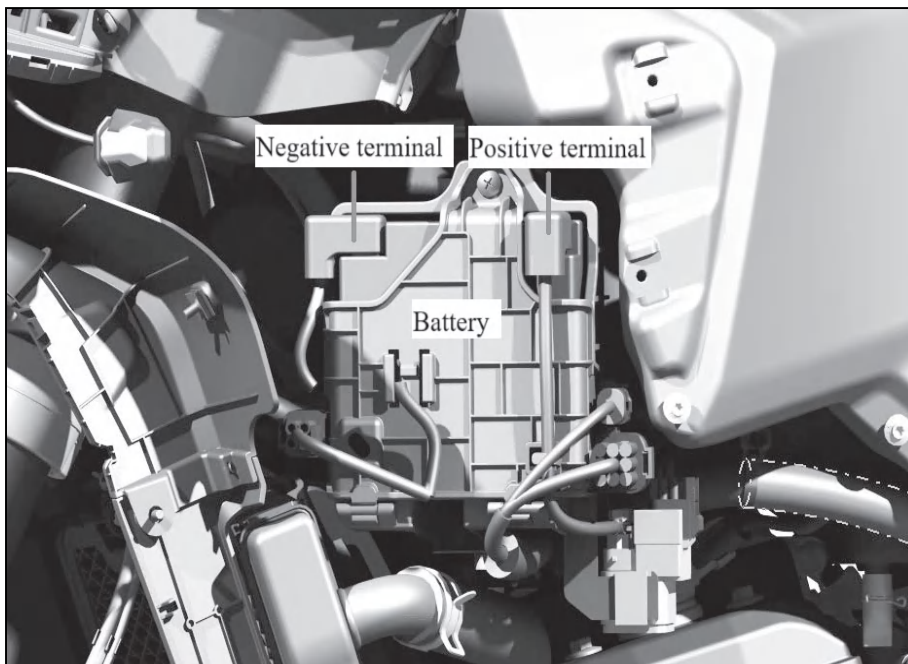

Remove

Confirm that the ignition switch is turned to the “” (OFF) position.

1. Remove the left fuel tank guard plate.
2. Remove the battery box cover.
3. Disconnect the negative (-) terminal of the battery.
4. Disconnect the positive (+) terminal of the battery.
5. Remove the battery, being careful not to leave the bolts and nuts.

Install

Install the components in the reverse order of removal, be sure to connect the positive terminal (+) first and the negative terminal (-) last; Make sure the bolts and nuts are tightened.

Seat

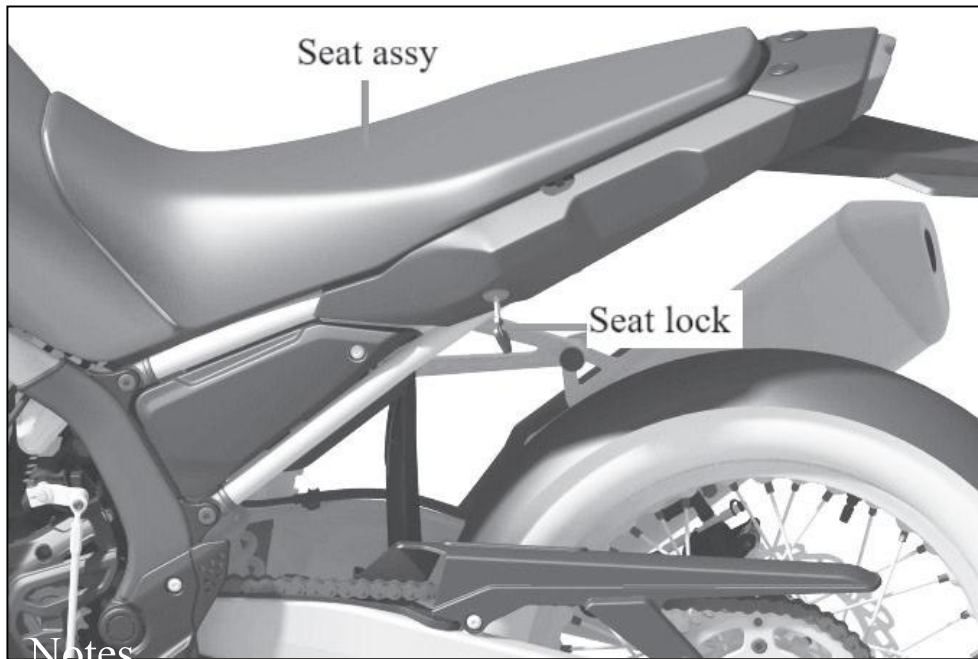

Notes

Remove

Insert the ignition key into the seat cushion lock, turn the key clockwise, pull up the rear end of the rear seat cushion assembly to disengage from the lock, and then remove the rear seat cushion assembly with a slight force to the rear.

Install

1. Insert the front and rear pins of the seat assembly into the frame slot respectively.
2. Align the seat lock pin with the lock hole, press the rear part of the seat downward, insert the lock pin into the lock hole of the seat lock and lock it automatically by the lock tongue, and pull it up slightly to ensure that the seat is firmly locked in place.
3. When the seat cushion is closed, the seat cushion lock automatically locks.

- Make sure that the seat cushion pin is correctly inserted into the frame card slot, otherwise the seat cushion product will not withstand your weight and the seat cushion product may be crushed.

Engine oil

Check and add engine oil

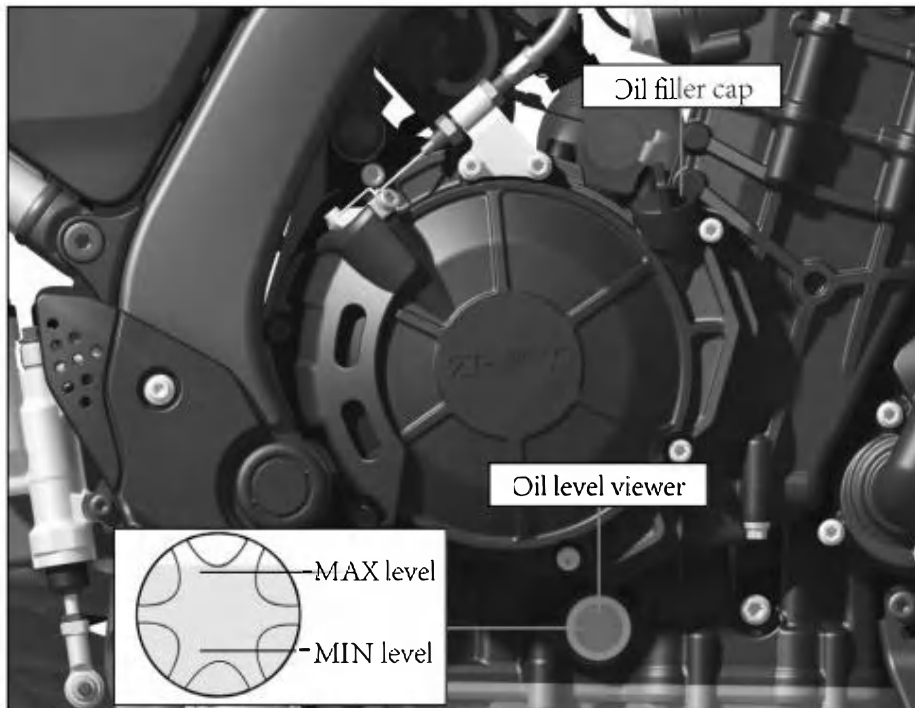

Check engine oil

1. Idle for 3-5 minutes, turn the ignition switch to the “” (OFF) position, and wait for 2-3 minutes.
2. Place the motorcycle vertically upward on a stable and flat ground, and check whether the oil level is between the upper and lower limit mark from the engine oil inspection window.

Add engine oil

- When the engine oil is below or near the lower oil level mark, add the recommended engine oil.
1. Remove the engine oil filler cap, add the recommended oil to the oil level mark, do not exceed the upper oil level mark, and ensure that no foreign substances enter the engine oil filler. If there is any spillage, wipe it off immediately.
 2. Refit the engine oil filler cap and tighten.

- Long-term skin contact with oil should be avoided, and the oil should be thoroughly washed after contact.
- Excessive oil or insufficient oil will damage the engine, please do not mix different brands and grades of oil, which will affect the lubrication and clutch operation.
- Used oil and containers are harmful to health and the environment and cannot be disposed of as daily waste. The treatment method should be consistent with local environmental regulations.

Replace the engine oil and the secondary oil filter

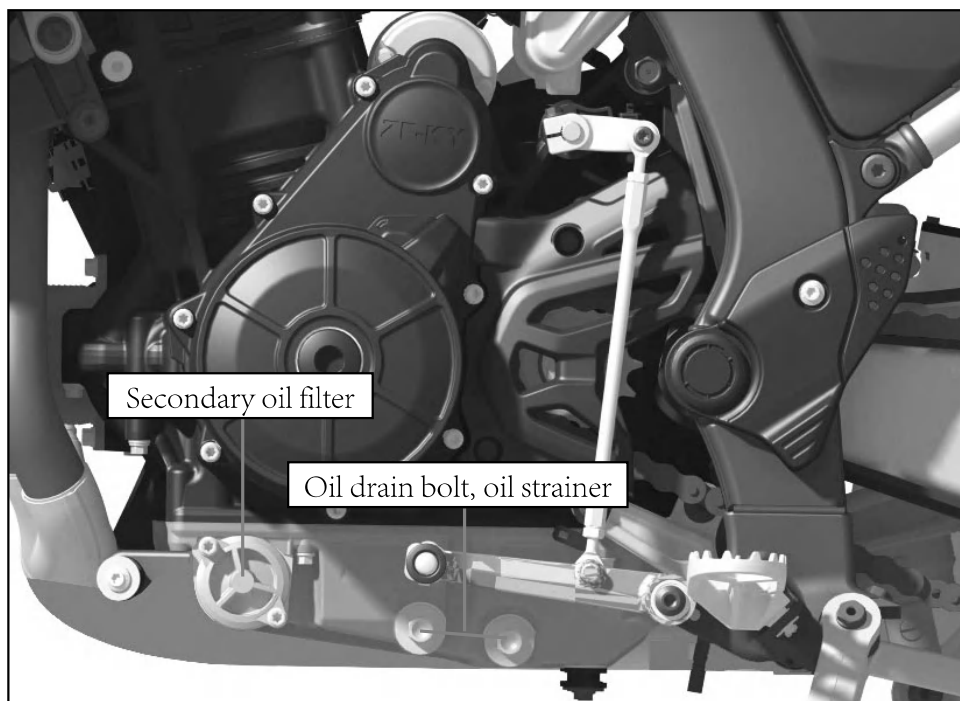

Replace the engine oil and the secondary oil filter

Special tools are required to replace the engine oil and the secondary oil filter. We recommend that the replacement be completed by a special repair shop of KOVEMOTO. Please refer to the "Maintenance Interval Table" for the maintenance interval of engine oil and secondary oil filter.

Use the original engine oil and secondary oil filter specified for your KOVEMOTO.

- 1.If the engine is cold, please idle for 3-5 minutes, turn the ignition switch to the "○" (OFF) position, and then wait for another 2-3 minutes.
 - 2.Park the motorcycle on a firm and flat level.
 - 3.Remove the lower guard plate of the engine and place an oil pan under the oil drain bolt.
 - 4.Remove the oil filler cap, 2 oil drain bolts and sealing washer, take out the oil strainer, drain the oil until the oil is in the form of drops.
 - 5.Remove the secondary oil filter cover, take out the filter, and drain the remaining oil.
 - 6.Replace with a new secondary oil filter and install the secondary oil filter cover (torque: 6 ± 1 N·m).
 - 7.Reinstall the cleaned oil strainer in the case.
 - 8.Install a new sealing washer on the oil drain bolt and tighten the oil drain bolt (torque: 20 N·m).
 - 9.Add the recommended original engine oil into the crankshaft tank, and tighten the oil filler cap after filling.
- When replacing the filter element, the required oil level: 3 L**
When the filter element is not replaced, the required oil level: 2.8 L
When reassembling after disassembling the engine, the required oil level: 3.2 L
- 10.Check the engine oil for leakage.

Precautions for replacing the engine oil and the secondary oil filter:

1. Using the wrong engine oil and secondary oil filter can seriously damage the engine.
2. Check and clean the oil strainer every time the engine oil is changed, and replace it in time if any damage is found.
3. When replacing the engine oil, replace the secondary oil filter.
4. When installing the secondary oil filter cover, replace the seal ring and coat grease.
5. The used engine oil, secondary oil filter and container are harmful to health and the environment. They cannot be disposed of as household waste and should be handled in accordance with local environmental regulations.

Coolant

Check coolant

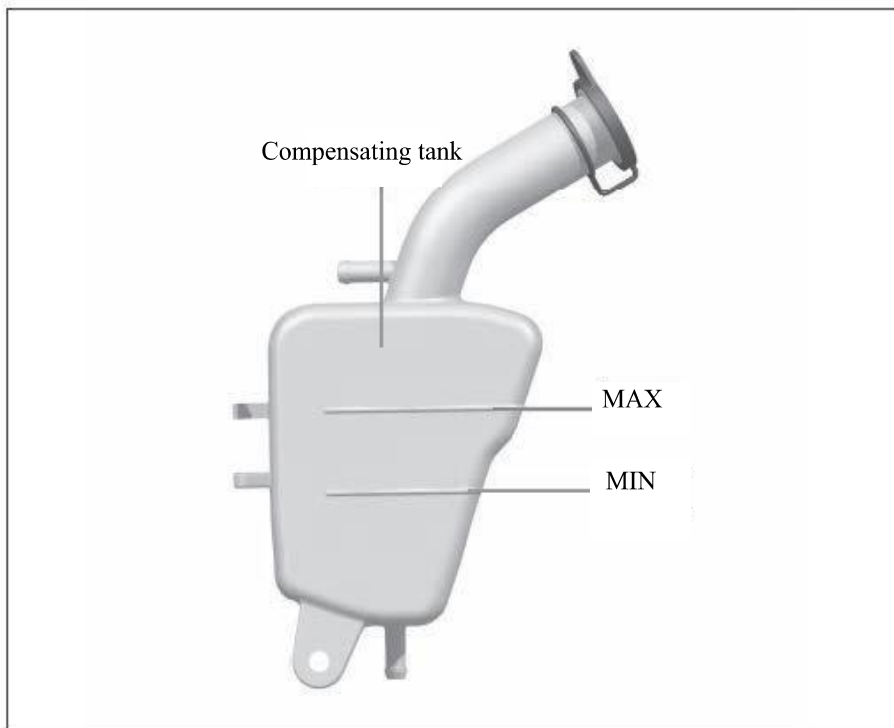

Check the coolant level in the water reservoir while the engine is cooling.

1. Park the motorcycle on a stable, flat, and level surface.
2. Keep the motorcycle straight.
3. Check that the coolant level in the water reservoir is between the upper and lower limit marks.
4. If the coolant level drops significantly or the water tank is empty, there may be a serious leak, which should be repaired by the special repair shop of KOVEMOTO.

Add coolant

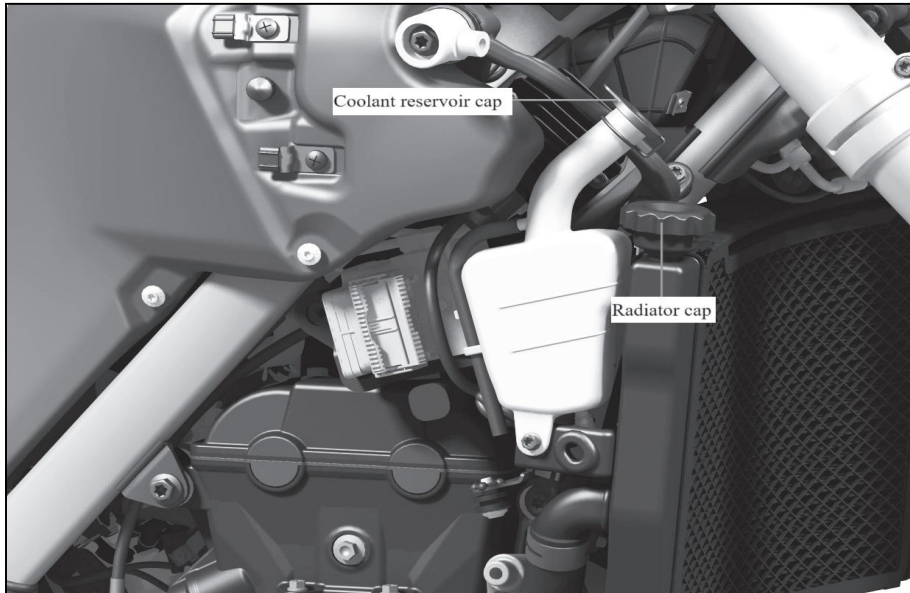

If the coolant level is below the lower limit level mark, add the recommended coolant until the level reaches the upper limit level mark.

When adding coolant, the radiator cap should be opened to relieve pressure when the engine is cool.

Open the cover of the water storage kettle at the other end to add. During the addition process, make sure that no foreign objects enter the closure opening and take care not to exceed the upper limit liquid level mark. After the addition is completed, reinstall the relevant cover.

Change coolant

Unless you have the appropriate tools and have qualified mechanical technology, please go to special repair shop of KOVEMOTO to replace the coolant.

Warning

- Do not remove the radiator cap when the engine is not cooling, this will cause the coolant to spray out, which may cause burns to you.

Brakes

Check brake fluid

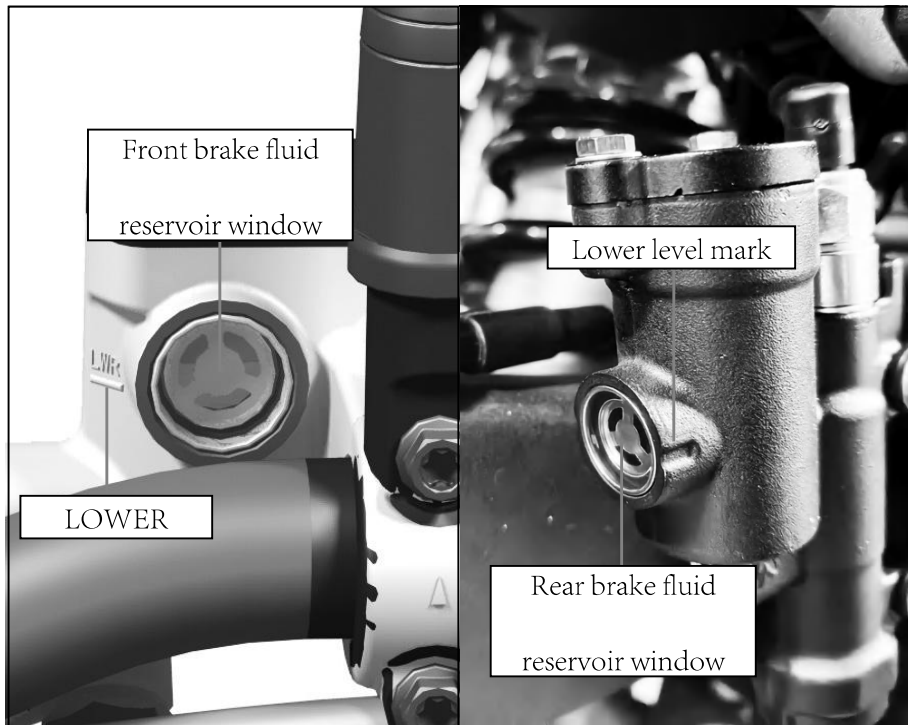

1. Place the motorcycle vertically up on a stable flat ground.
2. Check whether the brake oil cup is level.
3. Check the brake fluid level. If the brake fluid is below the lower level mark, add it immediately.

If the brake fluid level in the oil cup is lower than the lower limit (LOWER) level mark or the free stroke of the brake rod and pedal is out of limit, users must check whether the brake pad is worn. If the brake pad is not worn, there may be leakage. Please go to the special repair shop of KOVEMOTO for repair.

Check brake pads

Check the condition of the brake pad wear indication mark. If the brake pads wear to the indicator mark, they need to be replaced.

Front Check brake pads from under the brake caliper
Brake pad lining thickness: 4.8mm (indicated as wear limit)

Rear Check brake pads from the rear right of the brake caliper
Brake pad lining thickness: 7mm (indicated as wear limit)

If necessary, please hand over the brake pads to the special repair shop of KOVEMOTO for replacement (when the wear limit is reached, the left and right brake pads must be replaced at the same time).

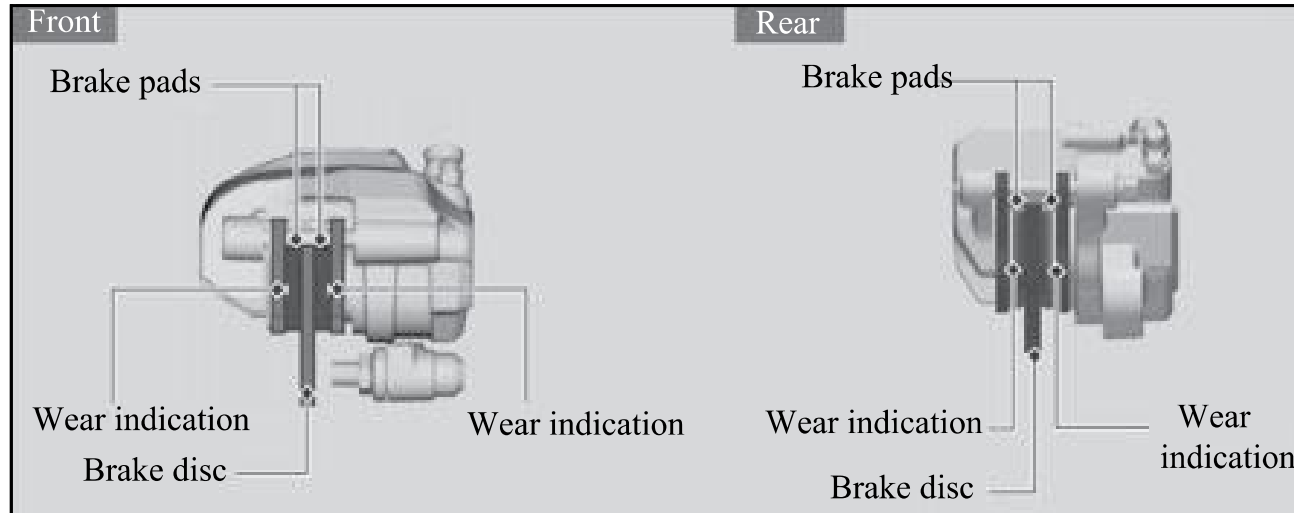

Side support

Check side support

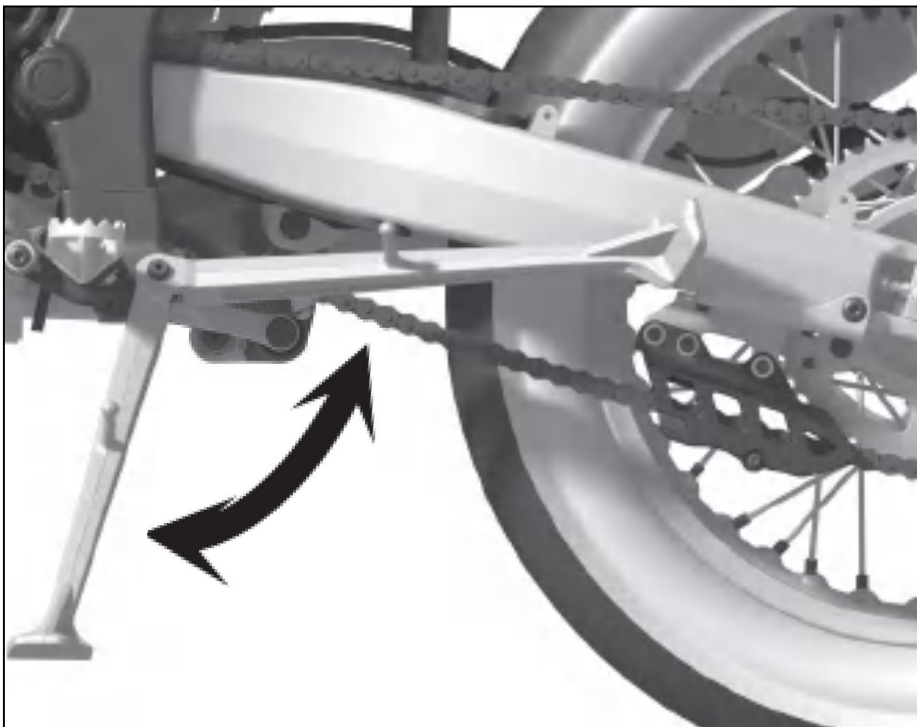

1. Check that the side supports are free to operate. If the side bracket operation is jammed or “squeaky”, clean the pivot area and grease the pivot bolt with clean grease.

2. Check the spring for damage or loss of elasticity.

Drive chain

Check the sag of the drive chain

Check the sag at different points along the chain. If the sag at all points is not uniform, some links may have been bent and kinked. Please check the chain at the special repair shop of KOVEMOTO.

1. Put the transmission into neutral and extinguish the engine.
2. Place the motorcycle vertically on a firm, flat ground.
3. Push the chain closer to the fork to determine if the chain sag is in the area behind the chain guard.
4. Turn the rear wheel forward to check that the chain runs smoothly.
5. Check sprockets.
6. Clean and lubricate drive chain.

Drive chain sag: 35-50mm

If the sag exceeds 50mm, you cannot continue to drive the motorcycle.

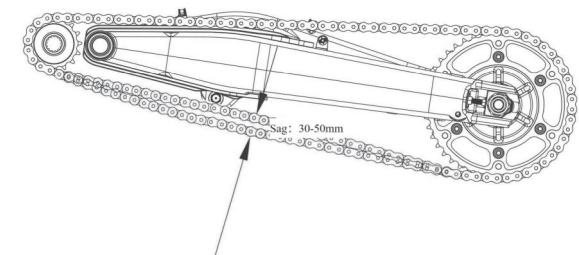

- When checking the drive chain sag, make sure that the upper part of the chain must be tensioned.

Adjust the sag of the drive chain

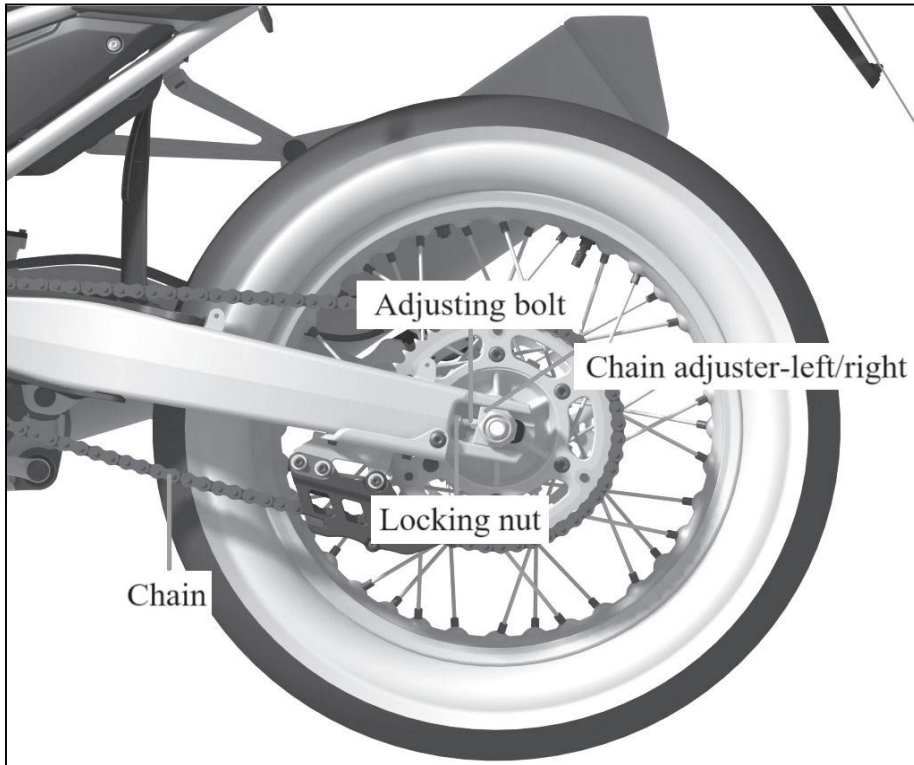

When adjusting the sag of the drive chain:

1. Put the transmission into neutral and turn off the engine.
2. Place the motorcycle vertically on a firm and flat ground.
3. Loosen the rear wheel axle nut.
4. Loosen the locking nut and chain tension adjusting bolt with an open-end wrench.
5. Rotate the chain tension adjusting bolt to adjust the chain sag. The chain sag adjustment range is: 35-50 mm (see for details in the sag diagram).
6. Push the chain in the direction of the plate fork at the middle of the upper part of the rear plate fork, to determine the reasonable sag of the chain.
7. The left/right chain adjusters shall be adjusted on the same scale line.

- When adjusting the drive chain sag, make sure that the upper part of the chain must be tensioned.

Clutch

Free travel of clutch handle: 3-6mm

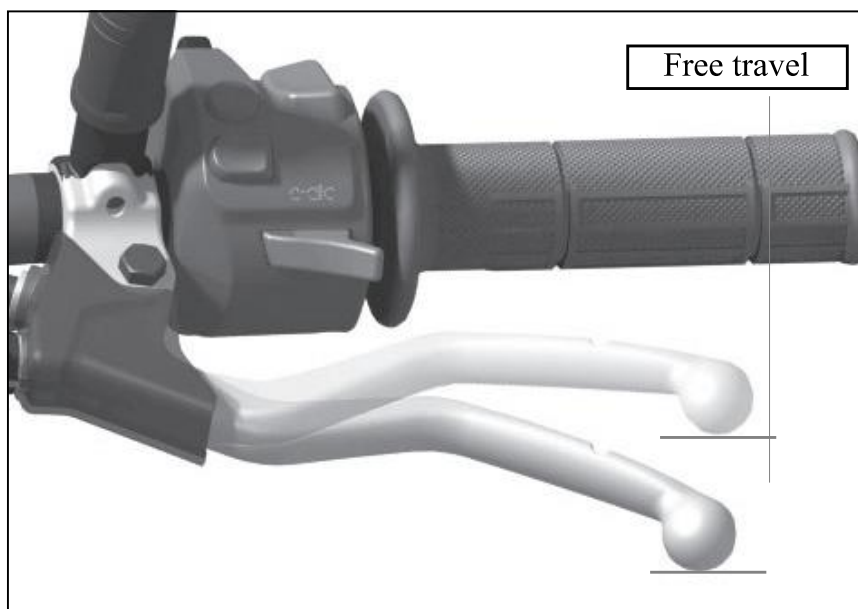

Check the clutch cable for bending and damage. If necessary, please go to the special repair shop of KOVEMOTO for replacement.

Lubricate the clutch cables with special cable oil to prevent premature wear and corrosion.

- Incorrect adjustment of the free travel can cause premature clutch wear.

Throttle

Check throttle

When the engine is off, check whether the throttle can be smoothly turned from the fully closed to the fully open position in all directions and the free stroke is correct.

If the throttle operation is not smooth, automatically closed or the cable is damaged, please go to the special repair shop of KOVEMOTO for repair.

Free travel of throttle handle flange: 2-6mm

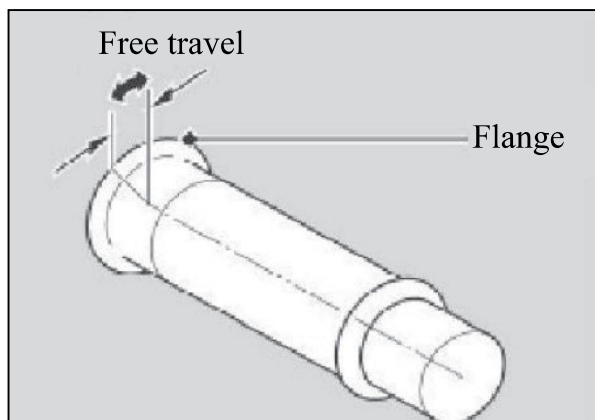

Adjusting the hand brake lever

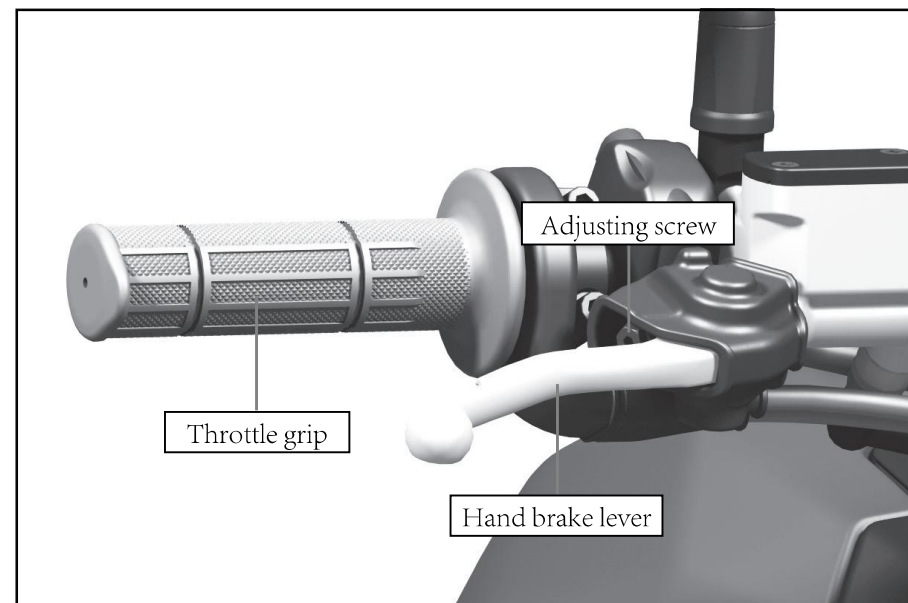

You can adjust the distance between the top of the brake handle and the handle rubber.

Adjustment method

Rotate the adjusting bolt counterclockwise to bring the hand brake lever closer to the handle; rotate the adjusting bolt clockwise to move the hand brake lever away from the handle.

The adjustment range is limited. Do not screw the adjusting bolt beyond its natural limit.

● No adjustment shall be conducted during riding.

Front shock absorber adjustment

Air pressure adjustment

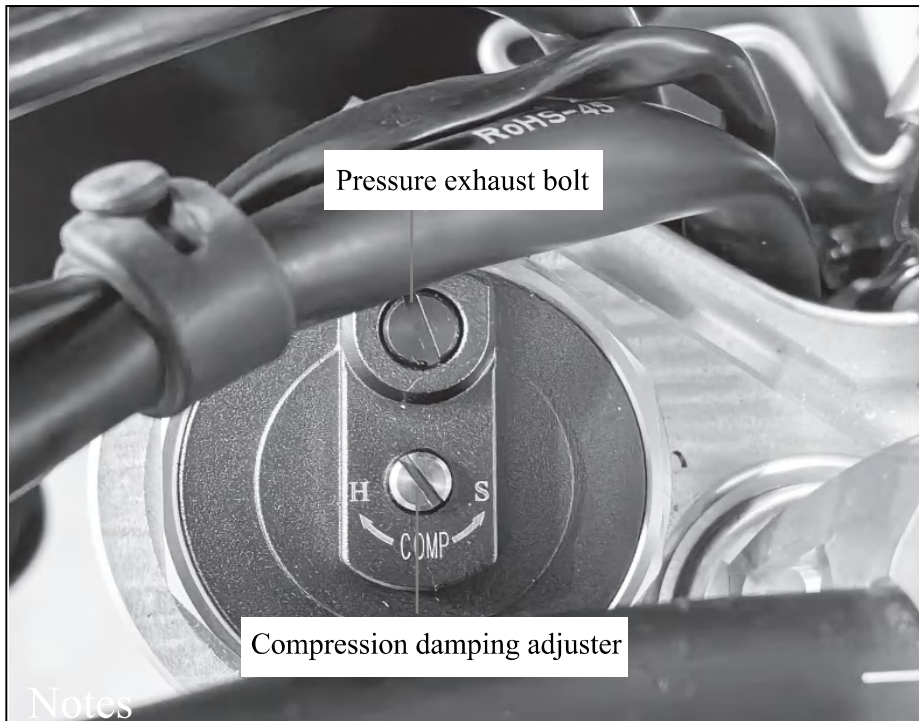

Notes

When the shock absorber is working, it will generate air pressure inside, which is like a progressive spring and will affect the entire stroke of the motorcycle. During a long ride, the front shock absorber will become harder. Therefore, the air pressure in the front shock absorber needs to be released in time.

You can use the pressure exhaust bolt to release the air pressure accumulated in the front shock absorber. Before releasing pressure, make sure that the front tire is off the ground. At this time, the front shock absorber is fully extended.

Adjustment method:

1. Place an optional workbench under the engine to lift the front wheels off the ground.
2. Remove the pressure exhaust bolt.
3. Apply No. 2 lithium grease to the O-ring and install it properly.
4. Tighten the pressure exhaust bolt (torque: 1.3 N·m).

- When discharging the air pressure of the front shock absorber, if the O-ring is broken, replace it in time.
- If the air pressure of the front wheels is adjusted on the ground, the wrong pressure degree will be given.

Compression damping adjustment



Compression damping adjuster

The adjustment of the compression damping affects the speed at which the front shock absorber compresses. The compression damping adjuster of the front shock absorber is located on the top of the left and right front shock absorbers, with the word "COMP" engraved. Adjust the slotted part of the stud center.

The compression damping has 22 segments, and each segment is 1/4 turn. Rotate the adjuster for one full turn, and the adjuster will rotate by 4 segments.

The compression damping increases when the adjuster is rotated clockwise (H), and the compression damping decreases when the adjuster is rotated counterclockwise (S).

Set standard compression damping:

1. Clockwise rotate the compression damping adjuster until it cannot be rotated.
2. Rotate the adjuster in a counterclockwise direction. The standard compression damping is to rotate 18 segments counterclockwise from the maximum position (the position where a click sound is heard).

● Do not rotate the adjuster with excessive torque, otherwise the adjusting device may be damaged. The adjustment torque shall not exceed 0.5 N·m.

Rebound damping adjustment

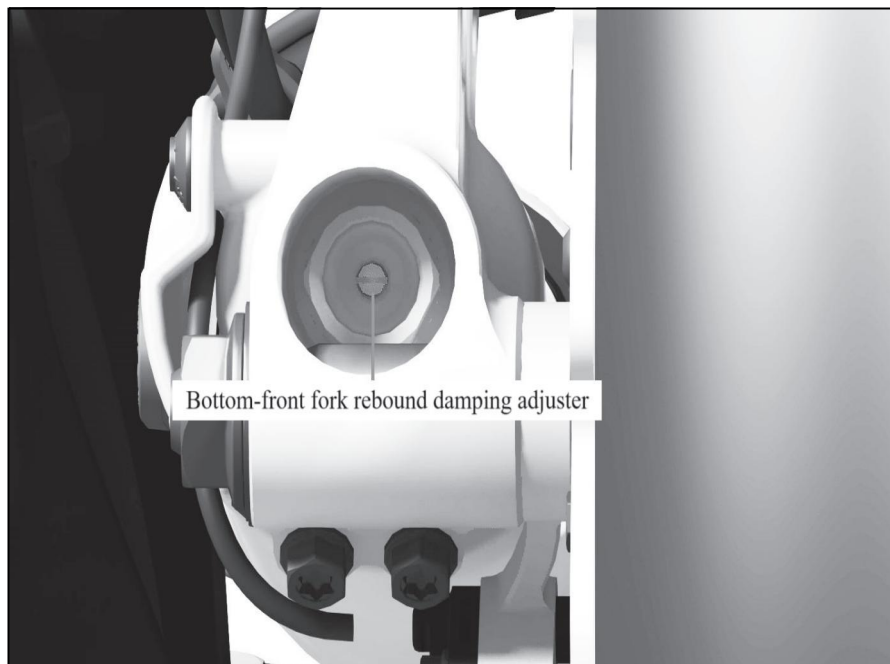

The adjustment of rebound damping will affect the rebound speed of the front shock absorber. The rebound damping adjuster of the front shock absorber is located at the bottom of the left and right front shock absorbers, with the word "TEN" engraved. Adjust the slotted part of the stud center.

The rebound damping of the front shock absorber has 22 segments, and each segment is 1/4 turn. Rotate the adjuster for one full turn, and the adjuster will rotate 4 sections.

The rebound damping increases when the adjuster is rotated clockwise (H), and the rebound damping decreases when the adjuster is rotated counterclockwise (S).

Set standard rebound damping:

1. Clockwise rotate the rebound damping adjuster until it cannot be rotated.
2. Rotate the adjuster in a counterclockwise direction. The standard rebound damping is to rotate 8 segments counterclockwise from the maximum position (the position where a click sound is heard).

- Do not rotate the adjuster with excessive torque, otherwise the adjusting device may be damaged. The adjustment torque shall not exceed 0.5 N·m.
- By turning the adjuster clockwise, both compression damping and rebound damping can be increased.

Rear spring strut adjustment

Airbag

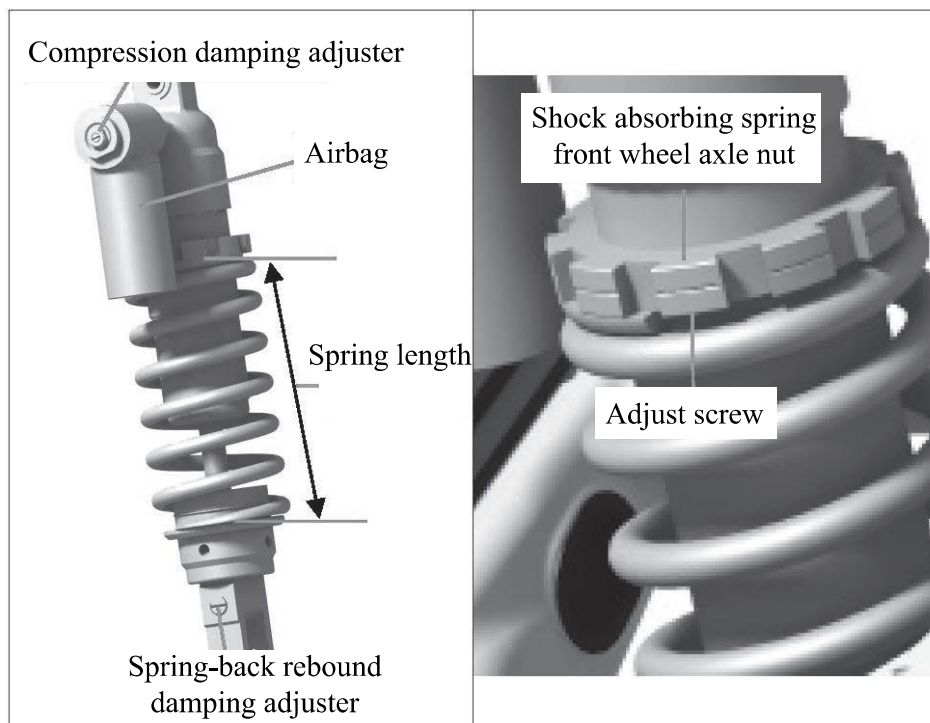

The rear shock absorber assembly includes a shock absorber bladder containing high pressure nitrogen. Do not attempt to remove, repair or dispose of the device. Piercing or exposure to flame may also cause an explosion, causing serious injury. Repair or disposal should be completed by special repair shop of KOVEMOTO.

Spring preload adjustment

The spring preload shall be adjusted when the engine is cooled, and the shock absorber spring preload adjusting knob shall be rotated to adjust the spring preload.

Adjustment method:

1. Securely support your motorcycle with a maintenance bracket or a crane and lift the rear wheels off the ground.

2. Check whether the spring preload is in the standard length.

3. Loosen the shock absorber spring locking nut and rotate the adjusting nut. The spring length will change by 1.5 mm for each turn of the adjusting nut.

4. Make corresponding adjustments as needed.

5. After the adjustment is completed, hold the adjusting nut and tighten the shock absorber spring lock nut (torque: 44N'm).

Increase spring preload:

Loosen the shock absorber spring lock nut with a special tool, rotate the adjusting nut, and shorten the spring length.

Reduce spring preload:

Loosen the shock absorber spring lock nut with a special tool, rotate the adjusting nut, and increase the spring length.

Each turn of the adjusting nut will change the spring length and spring preload,

Rebound damping adjustment

The compression damping can be adjusted separately for the bolt to conduct high-speed compression damping and low-speed compression damping. You can adjust it according to your weight and riding conditions.

High-speed compression damping adjustment

When it is necessary to adjust the compression damping of the shock absorber at high speed, adjust the hexagonal part of the compression damper, and adjust the stroke by about 4 turns. The compression damping increases after clockwise (H) adjustment, and the damping decreases after counterclockwise (S) adjustment.

Adjust to the standard position:

1. Rotate the adjuster clockwise (H) until it cannot be rotated.
2. Rotate the adjuster counterclockwise for 2 turns from the hardest position.

Low-speed compression damping adjustment

When it is necessary to adjust the compression damping of the shock absorber at high speed, adjust the center slotted bolt part of the compression damper. The adjustment range is 16 segments in total, and each segment is 1/4 circle. The compression damping increases after clockwise (H) adjustment, and the compression damping decreases after counterclockwise (S) adjustment.

Adjust to the standard position:

1. Rotate the adjuster clockwise (H) until it cannot be rotated.
2. Rotate the adjusting bolt for 8 segments counterclockwise from the hardest position (until a click sound is heard).

- Turn the adjusting bolt slightly to prevent damage to the rear shock absorber.
- When adjusting rebound damping or rebound damping, be sure to use the appropriate size of the tool to avoid damage to the device.
- Make sure that the adjusting bolt is firmly in the fixed position during each adjustment.

Rebound damping adjustment

The rebound damping adjuster is located at the left lower end of the rear shock absorber. The rebound damping increases when the adjuster is rotated clockwise (H), and the rebound damping decreases when the adjuster is rotated counterclockwise (S)....

Set standard rebound damping:

1. Rotate the rebounding damping adjuster clockwise (H) until it cannot be rotated.
2. Rotate the adjuster in a counterclockwise(S) direction. The standard rebound damping is to rotate 8 segments counterclockwise from the hardest position (the position where a click sound is heard).

Inspection of shock absorbers

Check and clean all parts of the shock absorber regularly to ensure optimum performance:

1. Check that the front shock absorber trim and dust seal are clean and that there is no soil or dirt on the front shock absorber.
2. Check for oil stains under the spring strut dust seal. If there are signs of oil leakage, replace the damaged dust seal and oil seal.
3. Pinch the hand brake lever and press the throttle grip back and forth several times to check whether the front shock absorber rebounds smoothly.
4. Press the seat cushion several times to check whether the rear shock absorber works smoothly.

Headlight

Adjust the headlight beam

You can adjust the angle of the headlight beam by rotating the adjusting screw, and the clockwise rotation is the overall decline of the headlight beam; The counterclockwise rotation is the overall rise of the headlight beam. Please comply with local laws and regulations.

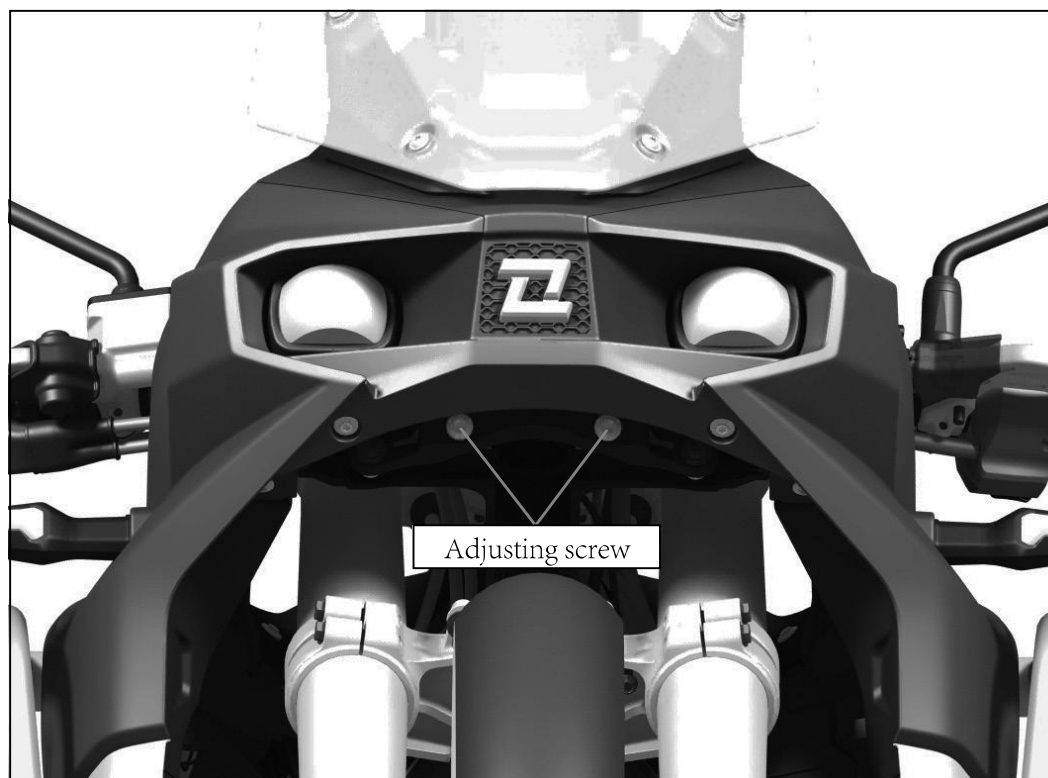

Troubleshooting

Please read “Maintenance” and “Maintenance Specification” carefully before maintenance, and refer to “Technical Parameters” for maintenance data.

The engine could not start	70
The warning indicator lights up or blinks	71
Puncture	73
Remove wheel	74
Electrical fault	77

The engine could not start

The starter motor ran but the engine failed to start

Check the following items:

- Check that the correct engine start sequence is used.
- Check if there is gasoline in the tank.
- Check if the battery voltage is too low.

The starter motor does not work



Check the following items:

- Verify that the engine start sequence is correct.
- Verify that the engine shutoff switch is in the run position.
- Check whether the battery voltage is too low, whether the fuse is blown, and whether the battery connection is loose. If the problem still exists, please go to the special repair shop of KOVEMOTO.

- Continuing to drive while the engine is overheated can seriously damage the engine.
- The engine runs at high speed in neutral for a long time, which may cause the water temperature to be too high.

Overheating (water temperature alarm indicator light up)

If the engine overheats when the water temperature alarm indicator is on and the speed increase is slow, please push the motorcycle to a safe roadside and take the following measures:

1. Turn off the engine with the ignition switch and turn to the “  ” (on) position.
2. Check that the radiator fan is operating properly, and then turn the ignition switch to the “  ” (OFF) position.

If the fan is not running: Do not start the engine, send your motorcycle to the special repair shop of KOVEMOTO.

If the fan is running: Place the ignition switch in the “  ” (OFF) position and wait for the engine to cool.

3. After the engine has cooled, check the radiator hose for leaks.

If there is a leak: Do not start the engine, send your motorcycle to the special repair shop of KOVEMOTO.

4. Check the coolant level in the compensating tank and add if necessary.
5. If items 1-4 are normal, you can continue to drive, but please pay close attention to the indicator light.

The warning indicator lights up or blinks

Oil pressure indicator

If the oil pressure indicator is on, push the motorcycle to a safe side of the road and turn off the engine, and take the following measures:

1. Check engine oil level and add oil if necessary.
2. You can continue to ride only after the indicator goes out.
3. When the oil is at or near the lower limit, a rapid increase in speed may cause the indicator light to illuminate.
4. If the oil level is at a normal level and the indicator is still on, please turn off the engine and contact the special repair shop of KOVEMOTO.
5. If the engine oil drops quickly, your motorcycle may leak oil or have other serious problems, please send it to the special repair shop of KOVEMOTO.

Electronic injection malfunction indicator light

If the electronic injection malfunction indicator light up during driving and riding, your electronic fuel injection system may have serious problems. Please slow down and send it to the special repair shop of KOVEMOTO.

●Continued driving at low oil pressure can seriously damage the engine.



ABS (Anti-lock braking system) - civil version

If any of the following conditions occurs in the ABS fault indicator, indicating that your ABS is faulty. The emergency brake will not be able to provide the anti-lock function, please send it to the special repair shop of KOVEMOTO as soon as possible.

- The ABS malfunction indicator is always on or flashing when riding.
- During riding, the ABS fault indicator lights up suddenly.
- When the speed is higher than 10km/h, the indicator does not extinguish.

The ABS malfunction indicator light may flash or stay on when:

- Turn the front wheel separately.
- Turn the rear wheel separately.
- Rear wheel slip.
- When riding on a special road.

The system can be reset by turning the ignition switch to the “  ” (OFF) position and then to the “  ” (ON) position.

Puncture

If the tire is punctured or damaged, please replace it instead of repairing it, since the repaired tire will not perform as well as a new tire. It may even break while you are riding. Special tools and skills are required for tire replacement. We recommend that such maintenance should be completed by special repair shop of KOVEMOTO.

- When discharging the air pressure of the front shock absorber, if the O-ring is broken, replace it in time.
- If the air pressure of the front wheels is adjusted on the ground, the wrong pressure degree will be given.

Remove wheel

Front wheel

If you need to remove the wheel to repair the tire tie, follow these steps. When you remove and install the wheel, be careful not to damage the wheel speed sensor and the ABS ring gear.

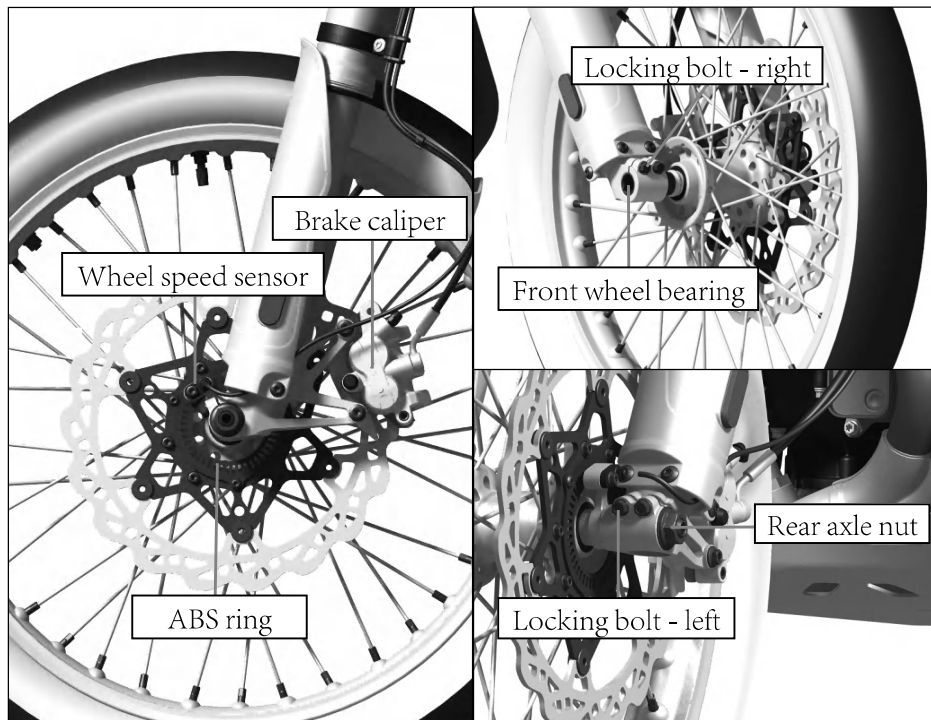

Remove:

1. Firmly support your motorcycle with a service bracket or crane and lift the front wheels off the ground.
2. Remove the left brake caliper.
 - Support the brake caliper assembly, do not hang on the brake hose, and do not twist the brake hose.
 - Avoid getting lubricating oil, oil or dirt onto the brake discs or pads.
 - Do not pull the brake handle when the brake caliper is removed.
 - Be careful not to scratch the wheel when removing the brake calliper.
3. Loosen the axle lock bolt and the front axle.
4. Remove front wheel axle and front wheel.

Install

1. Place the front wheel in the middle of the front shock absorber, place the front wheel bushing (left and right) into the front wheel oil seal (the left bushing is equipped with wheel speed sensor mounting lugs), and clamp the brake discs into the brake caliper.

2. Pass the front wheel axle from right to left through the front wheel, tighten the front wheel axle nut (front wheel axle M16; torque: 88 N·m), operate the hand brake lever for several times, shake the front fork up and down for several times, and then install the left and right 4 locking bolts (front wheel axle locking bolt M8, torque: 22 N·m).

3. Install the brake caliper and tighten the bolt (torque: 32 N·m). Prevent the brake caliper from scratching the wheel during installation. Please use a new assembly bolt when installing the brake caliper.

4. Position the front wheel to the ground.

5. Shake the front fork up and down several times after operating the brake handle several times.

- When installing the wheel or caliper in place, carefully install the brake disc between the brake pads to prevent it from being scratched.
- When installing the front wheel, you must first tighten the front wheel axle, and then tighten the lock bolt on the right side of the front wheel axle, and the order of the two cannot be exchanged.

Rear wheel

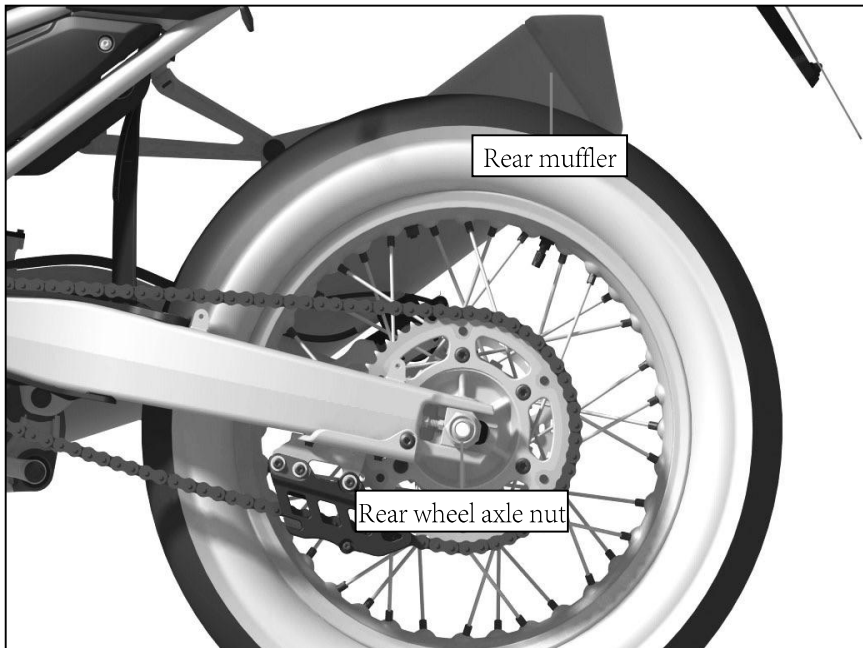

Remove

1. Park the motorcycle on a stable surface.
2. Firmly support your motorcycle with side brackets or service bracke and lift the rear wheels off the ground.
3. Remove the rear section of the muffler, a the chain guard.
4. Remove the rear axle nut, rear axle and rear wheel bushing.
5. Remove rear wheel.

Install

1. Install the rear wheels in the reverse order of removal to prevent the brake callipers from scratching the wheels during installation.

2. Align the rear wheel hole with the dowel pin on the rear wheel shaft, first install the rear wheel bushing (the bushing shall be coated with grease), and then insert the rear wheel shaft into the rear wheel assembly hole from left to right.

3. Tighten the rear axle nut (torque: 128 N·m).

4. Install the chain box and the rear section of the muffler.

5. Check the wheels, which shall rotate freely.

If the torque wrench is not used in the installation process, please send it to the special repair shop of KOVEMOTO as soon as possible, and improper installation will cause the brake performance to decrease.

- When installing the wheel or caliper in place, carefully install the brake disc between the brake pads to prevent it from being scratched.

Electrical fault

Blown fuse - civil version

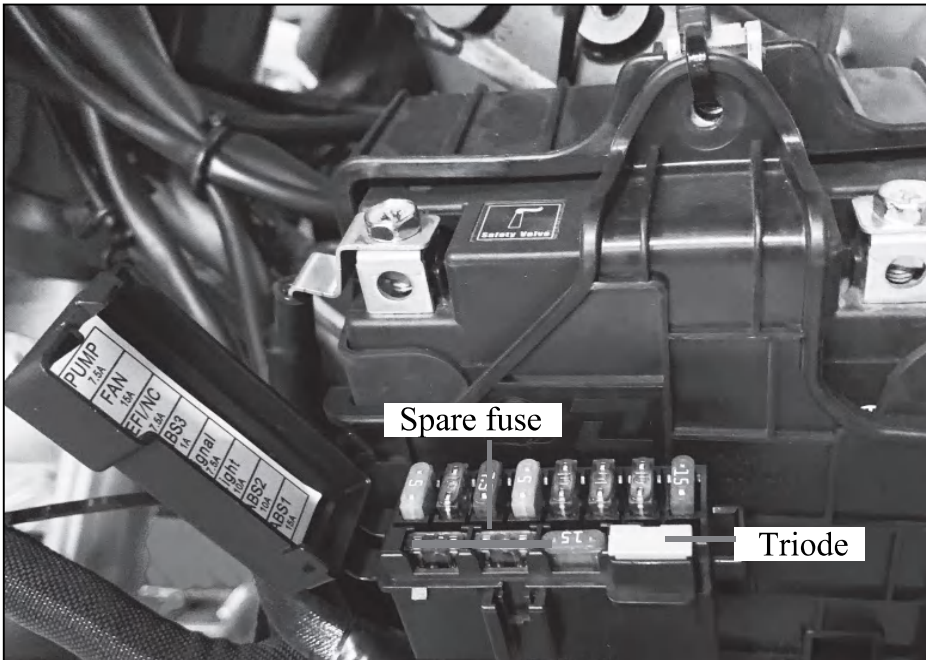

Blown fuse - competitive version

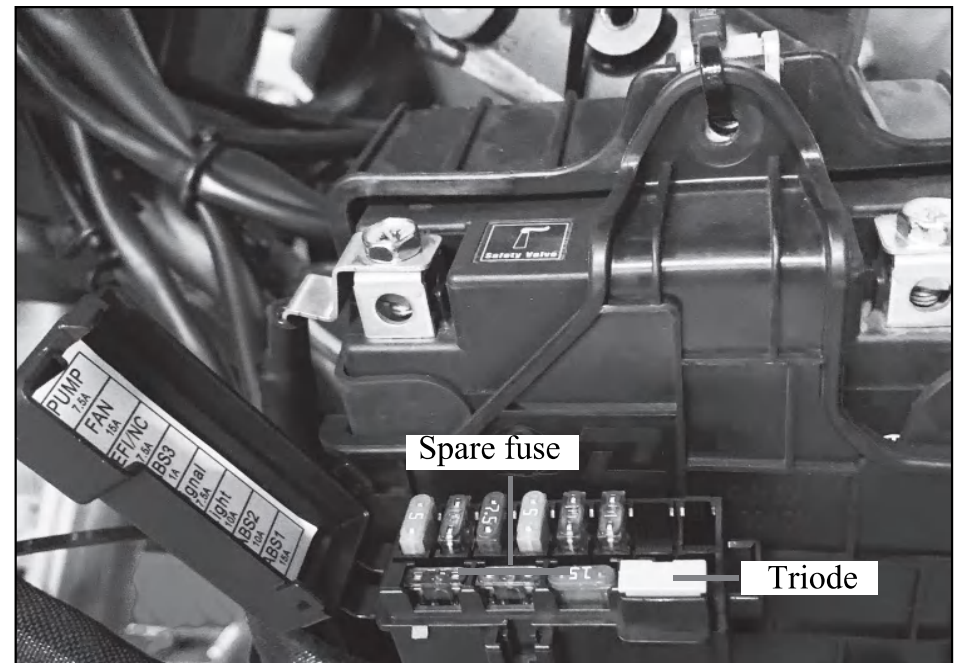

Electrical fault

1. Remove the left fuel tank side guard plate
2. Open the cover of the fuse box, take out the fuse, and check whether the fuse is blown. If it melts, be sure to replace it with a fuse of the same specification.
3. Close the safety box cover and install the Seat.

Run out of battery

Please use the special charger for motorcycle lithium battery to charge the battery. Remove the battery from the motorcycle before charging. If the battery is not recovered after charging, please contact the special repair shop of KOVEMOTO.



Notes

This model is factory-configured with a disconnected starter relay connector as the power cutoff method. To restore power, simply reconnect the starter relay connector.

- It is forbidden to use car battery chargers or motorcycle lead-acid battery chargers for charging, which may cause battery damage or even fire.
- Please refer to “Check and Replace Fuse” before handling the fuse.

Relevant information

Key 80

Instruments, controls and other functions 81

Maintenance of motorcycles 82

Motorcycle storage 85

Transport of motorcycles 85

You and the environment 86

Frame number, engine number, nameplate 87

Catalytic converter 88

Key

Ignition key



The motorcycle has two ignition keys to start the engine.



- Do not bend the key or subject it to excessive pressure.
- Avoid prolonged insolation or exposure to high temperatures.
- Do not grind, punch or change its shape in any way.

● In order to prevent loss, please take good care of your key. If you are worried about loss, please immediately re-engrave one.

Instruments, controls and other functions

Ignition switch, engine OFF switch

Ignition switch

1. In the parking state, please place the ignition switch in the “” or “” position to avoid unnecessary loss of the battery, and excessive battery power loss will lead to failure to start.

2. Do not turn the key while riding.

Engine OFF switch

Do not use the engine flameout switch unless in an emergency. Doing so while driving will cause the engine to stop suddenly, resulting in unsafe driving.

Mileage meter, milometer (subtotal mileage)

Odometer

When the reading exceeds 999,999, the display is locked at 999,999.

Milometer

When the milometer reading exceeds 999.9, it is automatically cleared.

Maintenance of motorcycles

Regular cleaning and polishing ensure a long motorcycle lifespan. A clean motorcycle makes it easier to spot potential faults. It is particularly noteworthy that anti-icing seawater and salt scattered on the road can accelerate corrosion. Be sure to clean the motorcycle thoroughly after driving on the coastal or above-mentioned road..

Cleaning

Wait for the engine, muffler, brake and other high temperature components to cool before cleaning.

1. Wash the motorcycle thoroughly with low-pressure hose and water to remove loose dirt.
2. If necessary, use a sponge or soft towel dipped in a soft detergent to remove the above dirt.
3. Wash the motorcycle thoroughly with sufficient water and dry it with a clean soft cloth.
4. After drying the motorcycle, lubricate the moving parts to ensure that no lubricant splashes on the brakes or tires. Oil-contaminated brake discs, brake pads, brake drums, and brake shoes will greatly reduce their braking performance and may cause accidents.
5. After cleaning and drying the motorcycle, lubricate the drive chain immediately.
6. Waxing can prevent corrosion.

Avoid using products containing strong detergents or chemical solvents, which can damage the metal parts, paint layers and plastic parts of the motorcycle. Do not wax the tires and brakes.

If your motorcycle is equipped with matte painted parts, do not wax these matte painted parts.

Cleaning notes

- Do not use high-pressure water guns:
 - ▶ High-pressure water guns can damage moving parts and electrical components, making them impossible to repair.
 - ▶ Moisture from the intake port may be sucked into the throttle body or into the air cleaner.
- Do not flush the muffler directly with water:
 - ▶ Water ingress into the muffler may cause starting issues and muffler rust.
- Dry brake:
 - ▶ Since the water will reduce the braking performance, the brake should be used at low speed intermittently after cleaning, and the brake pedal should be lightly depressed repeatedly, and the heat generated by the brake friction should be used to dry the water until the braking performance is restored.
- Do not flush directly under the Seat with water:
 - ▶ Water entering under the seat cushion may damage electrical appliance parts.
- Do not flush the air filter directly with water:
 - ▶ If water enters the air filter, the engine may not start.
- Do not flush directly with water near the headlights:
 - ▶ The internal lens of the headlamp may be temporarily fogged after cleaning or when cycling in the rain, which does not affect the function of the headlamp. However, if you find that a large amount of water or ice has accumulated in the lens, please send it to the special repair shop of KOVEMOTO.
- Do not wax and polish the matt finish:
 - ▶ Use sufficient water and a mild cleanser to clean matte paint surfaces, and dry them with a clean, soft cloth.

Aluminium components

Aluminum will corrode after contact with dirt, mud or salt, clean aluminum parts regularly, and follow the following guidelines to prevent scratches:

- Do not use hard brushes, wire balls, or other abrasive cleaning products.
- Do not drive or scratch on the curb.

Panel

Follow the following guidelines to prevent scratches and damage:

- Wash lightly with a sponge and enough water.
- Clean with diluted detergent and wash thoroughly with sufficient water to remove the scale.
- Please avoid contact of instrument panel and lamp cover with corrosive liquids such as gasoline and brake fluid.

Muffler

The muffler is stainless steel, but it may also be dirty because of mud or dust, you can use a wet sponge dipped in a cleaning agent to remove the mud or dust, and then carefully rinse with clean water, and then wipe with a chamois or soft towel. If necessary, burn marks can be removed with a commercially available compound of fine texture, and then washed in the same way as mud and dust.

If the muffler has been painted, use neutral detergent to clean the paint surface of the exhaust pipe and muffler, if you are not sure whether the muffler has been painted, please contact the special repair shop of KOVEMOTO.

Motorcycle storage

If you leave your motorcycle outdoors, you should consider using a motorcycle full-body shield. If you do not ride for a long time, follow the following guidelines:

- Clean the motorcycle and wax all paint surfaces (except for matte paint surfaces) and apply anti-rust oil to all chrome-plated parts.
- Lubricate drive chain.
- Place the motorcycle on the maintenance bracket and pad it up with a wooden block so that both tires are off the ground at the same time.
- After rain, remove the body cover and put it in a ventilated place to dry.
- Remove the battery to prevent discharge.

Fully charge the battery and place it in a cool, ventilated place. If you leave the battery in place, disconnect the negative terminal to prevent discharge. Before the stored motorcycle is reused, all items required in the maintenance cycle table should be checked.

Transport of motorcycles

If you need to transport your motorcycle, you should use a motorcycle trailer, a flat truck that loads a slope or a lifting platform, and you should use a motorcycle fixing belt. Never try to tow a motorcycle with its wheels on the ground.

- Towing a motorcycle can seriously damage the transmission.

You and the environment

Owning and driving a motorcycle is a pleasure, but you must protect the environment.

Select the appropriate cleaning agent

Use biodegradable detergents when cleaning motorcycles and avoid sprays containing chlorofluorocarbons (CFCs) as it can damage the protective layer (ozone layer) in the atmosphere.

Waste recovery

Separate the oil and other toxic waste in approved containers and send it to a recycling center. Call the local national public affairs or environmental services office to find the recycling center in your area and the disposal method of non-recyclable waste. Do not dump used engine oil in trash cans, sewers, or on the floor because used oil, gasoline, coolant, and cleaning solvents contain toxic substances. It harms cleaners and pollutes drinking water, lakes, rivers and the sea.

Frame number, engine number, nameplate

When registering a motorcycle, you need to provide the frame number and engine number, which are unique and used to identify your motorcycle. When ordering replacement parts, record these numbers and keep them in a safe place.

Frame number

The frame number is engraved on the right side of the frame girder



Engine number

The engine number is engraved on the right side of the engine crankshaft tank

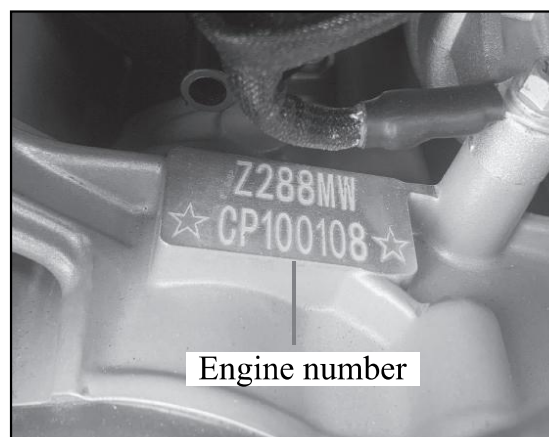

Nameplate

The nameplate is attached to the right side of the frame main beam tube



Catalytic converter

The motorcycle is equipped with a three-way catalytic converter. Catalytic converters contain precious metals as high-temperature chemical reaction catalysts to convert hydrocarbons (HC), carbon monoxide (CO) and nitrogen oxides (NOx) in the exhaust gas into a mixture that meets regulations.

Since a faulty catalytic converter can pollute the air and reduce your engine performance, be sure to use the original KOVEMOTO parts when replacing. Protect your motorcycle's catalytic converter with the following guidelines:

- Only use unleaded gasoline, leaded gasoline will damage the catalytic converter.
- Keep the engine in good working order.
- If the engine does not catch fire, backfire, flameout or other bad operation, please immediately stop driving and turn off the engine, and hand over the motorcycle to the special repair shop of KOVEMOTO.

Technical parameters

Motorcycle related parameters	90
Torque parameters	92
Frame tightening torque	93

Motorcycle related parameters - 1

Model	ZF800LS	Engine number	Z288MW
Overall length (mm)	2267	Cylinder diameter (mm) × stroke (mm)	88.0×65.7
Overall width (mm)	880	Compression ratio	11.3:11.3: 1
Overall height (mm)	1395	Maximum power (kW/r/min)	69.5 kW/9500r/min
Wheelbase (mm)	1545	Maximum torque (N·m/r/min)	79N·m/8500r/min
Track gauge (mm)	/	Idle speed (r / min)	1400±100
Curb weight (kg)	176	Piston swept volume (ML)	124.8
Payload (kg)	164	Spark plugs	LMAR9AI-10
Front tyre size	90/90-21	Spark plug gap (mm)	0.9-1.0
Rear tyre size	140/80-18	Valve clearance (mm)	In: 0.1-0.15
Maximum speed (km / h)	210		Out: 0.15 -0.2

Motorcycle related parameters - 2

Lubriating oil capacity (L)	3.2	Main fhase	30A
Gasoline capacity (L)	20L	Neutral light	LED light
Primry transmiission ratio	1.923	Headlight	LED light
First gear	2.846	Front position light	LED light
Second gear	2.000	Rear position light / brake light	LED light
Third gear	1.550	Front tum signal	LED light
Fourth gear	1.273	Rear tum signal	LED light
Fith gear	1.083	Rear license plate light	LED light
Sixth gear	0.957	Tum indicator light	LED light
Final transmission ratio	3.000	Instrurent inclication light	LED light
Battery	12v 6Ah (Lithium batteries)	Ignition mnode	ECU controls the ignition

Torque parameters

Fasteners type	Torque	Fasteners type	Torque
5mm bolts and nuts	6	6mm bolts	8
6mm bolts and nuts	12	6mm flange bolt (8mm head: small flange)	10
8mm bolts and nuts	22	6mm flange bolt (8mm head: big flange)	12
10mm bolts and nuts	60	6mm flange bolt (10mm) and nuts	12
12mm bolts and nuts	80	8mm flange bolt and nuts	22
5mm bolts	5	/	/

- In addition to the specified torque, the motorcycle adopts the standard torque values in the table above.

Frame tightening torque

Project	Thread diameter (mm)	Torque (N·m)	Note
License plate light panel screw with rear fender bracket	ST3.5	1	
Rear fender screw with rear fender bracket	ST4.2	1	
Body liner screw (left, right) connecting with the frame (left, right)	ST4.2	1	
Radiator grille screw (left, right) with the fuel tank side guard (left, right)	ST4.2	1	
Fuel tank side guard liner screw (left, right) with its side guard (left, right)	ST4.2	1	
Fuel tank side trim (left, right) screw with its side guard (left, right)	ST4.2	1	
OBD fixing screw	ST4.2	1	
Body liner screw (left, right) with front rear fender	ST4.8	1	
Fuel tank drain plate cross screw with fuel tank	M5	5	
Fuel pump cross screw with fuel tank	M5	3	
Oil hose clip hexagon flange bolt (plain fork)	M5	6	
Rear ABS ring gear hexagon screw (front hub)	M5	4	Thread gluing, Huitian 7272
Rear brake pedal hexagon flange bolt (brake rocker arm)	M5	3	Thread gluing, Huitian 7272
ECU cross screw with front rear fender	M5	3	
Fuel level sensor cross screw with fuel tank	M5	3	
Fuel level sensor bracket cross screw (fuel tank)	M5	3	
Tail light assembly cross screw (rear tail cover)	M5	5	
Roll sensor cross screw (carbon canister)	M5	3	
Rear fender inner panel hexagon screw (rear fender)	M5	5	
Rear fender inner panel bracket hexagon screw	M5	6	
Rear tail panel hexagon screw (rear fender)	M5	6	

Project	Thread diameter (mm)	Torque (N·m)	Note
Fuel tank lock seat hexagon screw (fuel tank)	M5	3	
Rear wheel mud guard hexagon screw (rear fender front trim)	M5	6	
Screw connecting fuel tank lower guard (left, right) with fuel tank	M5	6	
Headlight trim hexagon screw (left, right fuel tank cowling)	M5	6	
Fuel tank side cowling hexagon screw (left, right fuel tank)	M5	6	
Fuel tank protector hexagon screw (fuel tank)	M5	6	
Fuel tank protector hexagon screw (left, right instrument rear section)	M5	6	
Instrument rear section hexagon screw (left, right fuel tank)	M5	6	
Upper bracket cable guide bolt	M5	6	
Cross screw connecting the battery box cover and the battery box	M5	6	
Fuel tank side cowling screw (left, right instrument housing)	M5	6	
Headlight trim hexagon screw (instrument housing)	M5	6	
Headlight trim hexagon screw (instrument bracket)	M5	6	
Cross screw connecting the headlight bracket and headlight assembly	M5	6	
Headlight bracket panel hexagon screw (headlight bracket)	M5	6	
Windshield assembly hexagon screw	M5	6	
Cross screw connecting instrument bracket and instrument trim	M5	6	
Cross screw connecting instrument bracket and instrument assembly	M5	6	
Hexagon lobular socket pan head screw for front brake pipe clamp locking connection	M5	3	
Guide chain hexagon flange bolt (guide chain wear block)	M5	3	
Guide chain hexagon self-locking nut (guide chain wear block)	M5	3	

Project	Thread diameter (mm)	Torque (N·m)	Note
Seat lock hexagon screw (frame)	M6	8	
Rear brake valve hexagon screw (frame)	M6	10	
Fuel tank side cowling bracket Philips screw (fuel tank)	M6	6	
Seat fixing bracket hexagon screw (fuel tank)	M6	6	
Seat bracket Philips screw (fuel tank)	M6	6	
Magneto plug bracket Phillips screw (fuel tank)	M6	6	
ABS bracket hexagon flange bolt (frame)	M6	10	
ABS bracket hexagon screw (ABS)	M6	10	
Fuel tank side cowling bracket hexagon screw (left, right)	M6	10	
Muffler covers hexagon crew (muffler)	M6	10	
Water reservoir hexagon bolt with flat washer (radiator)	M6	10	
Top radiator bracket hexagon bolt	M6	10	
Bottom radiator bracket hexagon bolt	M6	10	
Shift arm pinch hexagon flange bolt	M6	10	
Shift arm and rod hexagon bolt	M6	10	Thread gluing, Huitian 7272
Shift rod bearing hexagon nut (shift lever, left rotation)	M6	6	
Shift rod bearing hexagon nut (shift lever, right rotation)	M6	6	
Shift rod bearing hexagon bolt (shift pedal rod)	M6	10	Thread gluing, Huitian 7272
Fuel rail hexagon flange bolt	M6	10	
Charcoal canister hexagon flange bolt (frame)	M6	10	
Air filter hexagon flange bolt (frame)	M6	10	

Project	Thread diameter (mm)	Torque (N·m)	Note
Brake rocker arm hexagon flange bolt (rear brake rod bearing)	M6	10	
Front wheel speed sensor bolt	M6	8	
Front wheel speed sensor bolt	M6	8	
Horn hexagon flange bolt	M6	10	
Rectifier hexagon flange bolt (frame)	M6	10	
Ground wire on frame hexagon flange bolt (left front)	M6	10	
Engine guard (Lower) hexagon bolt	M6	10	
Engine guard (Side) hexagon screw	M6	10	
Engine sprocket cover bolt	M6	10	
Chain guard hexagon screw (plain fork)	M6	10	
Front rear fender hexagon screw (subframe side mounting point)	M6	8	
Rear fender inner panel bracket hexagon bolt (rear fender bracket on frame)	M6	10	
Rear tail cover trim hexagon screw (left, right inner liner)	M6	8	
Rear tail cover and trim hexagon screw (frame)	M6	8	
Frame liner (left, right) hexagon screw (subframe)	M6	8	
Front rear fender hexagon screw (subframe)	M6	8	
Front rear fender trim hexagon screw (front rear fender)	M6	8	
Front rear fender trim hexagon screw (subframe)	M6	8	
Fuel tank side (left, right) connecting fuel tank lower guard (left, right) hexagon screw	M6	8	
Battery support hexagon flange bolt (frame)	M6	10	
Instrument bracket hexagon flange bolt (frame)	M6	10	

Project	Thread diameter (mm)	Torque (N·m)	Note
Front windshield bracket hexagon screw (instrument bracket)	M6	10	
Front disc brake hexagon flange bolt (front hub)	M6	10	Thread gluing, Huitian 7272
Guide chain hexagon flange bolt (mounting bracket)	M6	8	
Guide chain mounting bracket hexagon bolt (plain fork)	M6	8	
Steering damper adjusting seat hexagon flange bolt (frame)	M6	10	
Rear disc brake hexagon flange bolt (rear hub)	M6	10	Thread gluing, Huitian 7272
Front fender hexagon flange bolt (lower connecting plate)	M6	8	
Front brake pump hexagon flange bolt (rearview mirror seat)	M6	10	
Steering damper adjusting seat hexagon flange screw (upper connecting plate)	M6	10	
Front shock absorber trim hexagon screw (front shock absorber)	M6	8	
Ignition lock hexagon bolt	M8	22	
Brake rocker arm hexagon bolt (frame)	M8	25	Thread gluing, Huitian 7272
Crash bar bracket hexagon flange bolt (left, right frame)	M8	22	
Crash bar hexagon flange bolt (left, right frame)	M8	22	
Fuel tank (front and rear) hexagon flange bolt	M8	22	
Engine fixing arm linkage bracket left bottom hexagon flange bolt (engine)	M8	22	
Engine fixing arm linkage bracket left bottom hexagon flange bolt (frame)	M8	22	
Engine fixing arm linkage bracket right bottom hexagon flange bolt (frame)	M8	22	
Engine fixing arm linkage bracket right front bottom hexagon flange bolt	M8	22	
Muffler hexagon flange bolt (frame)	M8	22	
Muffler hexagon flange nut (engine)	M8	18	
Shift pedal connecting rod hexagon bolt (frame)	M8	25	Thread gluing, Huitian 7272
Handlebar clamp hexagon bolt	M8	22	

Project	Thread diameter (mm)	Torque (N·m)	Note
Upper bracket pinch hexagon flange screw	M8	22	
Cut-off switch wire bracket and engine lower reinforcement bracket (left) hexagon flange bolt (engine)	M8	22	
Guide chain bracket hexagon bolt (plain fork)	M8	15	
Upper bracket pinch hexagon flange screw	M8	22	
Front shock absorber hexagon flange bolt (Tesk caliper)	M8	35	Thread gluing, Huitian 7272
Large sprocket hexagon flange self-locking nut (buffer)	M8	37	
Large sprocket hexagon screw (buffer)	M8	37	
Front shock absorber hexagon flange bolt (front wheel axle lock)	M8	22	
Upper connecting plate hexagon flange nut (lower clamp seat of steering handle)	M8	22	
Muffler bracket hexagon flange bolt to the subframe (competitive version)	M8	22	
Rear muffler hexagon flange bolt to the muffler bracket (competitive version)	M8	22	
Engine mounting hexagon flange screw (rear)	M10	54	
Engine mounting hexagon flange nut (rear)	M10	54	
Engine mounting hexagon flange bolt (left upper side)	M10	54	Thread gluing, Huitian 7272
Engine mounting hexagon flange bolt (right upper side)	M10	54	Thread gluing, Huitian 7272
Engine mounting hexagon flange bolt (front upper)	M10	54	Thread gluing, Huitian 7272
Engine mounting hexagon flange bolt (front bottom)	M10	54	Thread gluing, Huitian 7272
Crash bar bracket hexagon flange bolt (left, right crash bar)	M10	45	
Engine fixing arm linkage bracket left hexagon flange bolt (engine)	M10	44	Thread gluing, Huitian 7272
Engine fixing arm linkage bracket right hexagon flange bolt (engine)	M10	44	Thread gluing, Huitian 7272
Rear shock absorber hexagon flange bolt (frame)	M10	44	
Rear shock absorber hexagon flange nut (frame)	M10	44	

Project	Thread diameter (mm)	Torque (N·m)	Note
Triangular rocker hexagon flange nut	M10	44	
Triangular rocker hexagon flange bolt	M10	44	
Front brake hose union bolt to front caliper)(competitive version)	M10	22	
Dedicated screw for side stand	M10	Tighten the bolt 22 N·m(1.5 lbf ft), and then tighten the hexagon bolt without moving, fasten nut 22 N·m(16.2 lbf ft)	Thread gluing Huitian 7272, grease on polished rod
Hexagon flange self-locking nut for side stand			
Brake hose with ABS union bolt (civilian version)	M10	22	
Brake hose 3 union bolt to front caliper side (civilian version)	M10	22	
Brake hose 5 union bolt to rear caliper side (civilian version)	M10	22	
Upper connecting plate double-head thread cylinder (lower clamp seat of steering handle)	M10	30	
Triangular rocker hexagon flange bolt	M10	44	
Subframe hexagon bolt (main frame)	M10	45	
U-shaped rocker hexagon flange bolt (frame)	M12	60	
Triangular rocker hexagon flange bolt (U-shaped rocker)	M12	60	
Triangular rocker hexagon flange bolt (plain fork)	M12	60	
Triangular rocker flange bolt (U-shaped rocker)	M12	60	
Triangular rocker flange nut (plain fork)	M12	60	
U-shaped rocker flange nut (frame)	M12	60	
Front wheel axle locking nut	M16	88	
Plain fork axle locking nut	M16	88	

Project	Thread diameter (mm)	Torque(N·m)	Note
Steering column locking bolt	M16	70	
Rear wheel axle locking nut	M22	128	
Steering head ring nut	M25	The first stage: 40 Nm (29.5 lbf ft), loosening the nut in the second stage, tighten the nut to 10 Nm (7.4 lbf ft). In the third stage, keep the steering head fixed and loosen it by 1/4 turn.	

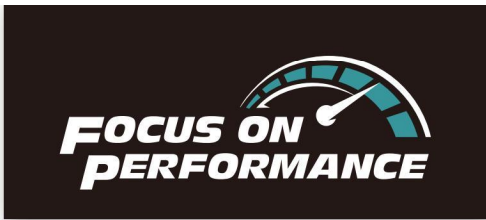

<https://www.kovemoto.com>

Tibet New Summit Motorcycle Co., Ltd. All rights reserved.

Version: 11/2024