

**KOVE** | 凯越  
机车



**KY600GY**

Two-Wheel Motorcycle Instruction Manual

TIBET NEW SUMMIT MOTORCYCLE CO., LTD.

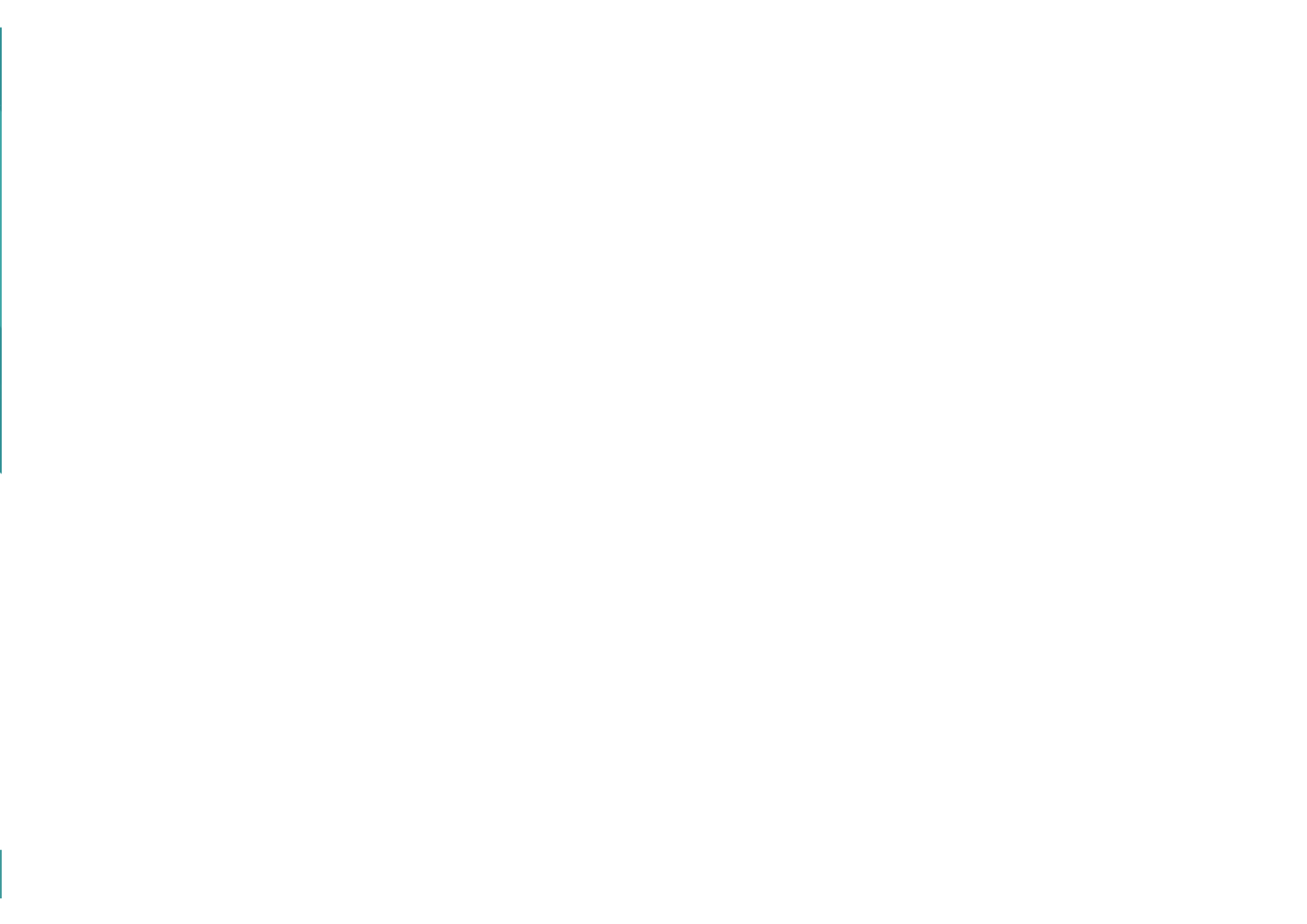

# KOVE RACING

On the world stage since 2023



From road racing to rally raids—  
facing the fastest, forging history.

**SBK** SUPERSPORT300  
FIM WORLD CHAMPIONSHIP

# WorldSBK

The world's premier production-motorcycle racing series.



October 19, 2025

KOVE 350RR claimed the WSBK-SSP300  
World Championship title.



The 2025 season marked the final year of the SSP300 class. The category will be replaced by the SportBike class

**Since entering the WSBK in 2023, KOVE secured the SSP300 overall championship in just three seasons, along with 4 race wins, 6 runner-up finishes, and 5 third-place finishes.**

# DAKAR RALLY

– The world's toughest rally raid

## 2023 Season

Three KOVE 450 RALLY bikes entered the race, and KOVE became the first manufacturer worldwide to finish Dakar with every bike on its debut.



## 2024 Season

With the newly developed in-house engine, the 450 RALLY EX achieved P3 in SS1 and P5 in SS5.

## 2025 Season

KOVE factory team secured P15 overall, reshaping global perceptions of Chinese motorcycle performance, attracting an increasing number of professional riders to choose KOVE.





## Racing Fuels Production

Beyond WSBK and Dakar, KOVE continues to raise the bar across the Rallye du Maroc, the BAJA World Cup, and the BSB Championship—showing the strength of Chinese engineering on the global stage.

If racing cannot shape the product, it loses its meaning. Results are only a by-product; the goal is always to serve the rider.

Breaking technical barriers through competition.

Advancing product performance through real racing.

## To Our Distinguished Owner

625X Two-Wheel Motorcycle Instruction Manual

First Edition (December 2025)

First of all, congratulations on your purchase of a brand new KOVEMOTO!

If you choose products of KOVEMOTO, you will become a member of the KOVEMOTO family.

This Instruction Manual introduces the main specifications, basic structure, adjustment method and maintenance knowledge of the motorcycle. It will guide you to master the basic operation of the motorcycle and eliminate or reduce common faults, which can effectively ensure driving safety, play the best performance of the vehicle, and improve the service life of the vehicle.

**This Instruction Manual contains the introduction of the basic configuration of the motorcycle. The contents and pictures are for reference only, please refer to the physical object.**

**Due to the production time, user needs and design improvements, the actual motorcycle may be different from the contents of the Manual. We reserve the right to make changes at any time, and we will no longer notify and assume any obligations. Sorry for any inconvenience caused.**

The Instruction Manual is one of the necessary accessories of the motorcycle, and when it is sold to others, it should be attached to the motorcycle.

The copyright of this Instruction Manual belongs to the company, and no reproduction is allowed without the written consent of the company, and violators will be prosecuted.

To ensure your safety, and increase your riding pleasure:

- Please read the Instruction Manual carefully.
- Please follow all recommendations and procedures in the Instruction Manual.
- Please pay close attention to the safety information recorded in the Instruction Manual and pasted on the motorcycle body.

## Safety Precautions

The safety of you and others is very important, and the safe driving of this motorcycle is an important responsibility.

To help you make an informed decision about your safety, we provide steps and other information on the safety label and in the Instruction Manual to remind you. This information is intended to alert you to the potential danger of harm to you or others.

It is impractical for us to list all the hazards associated with motorcycle riding and maintenance, and you must make the right judgment yourself.

It is prohibited to install additional electrical appliances, as this may result in battery drain.

The motorcycle is equipped with a high-speed engine. For your driving safety, it is recommended that you reduce violent driving.

You'll see important security information in a variety of forms, including:

- Safety labels on the body of a motorcycle;
- The safety information is preceded by a safety warning symbol  and one of the following three warnings : Caution, danger, and warning.

** Caution** - If you do not follow the instructions, you may be injured.

** Danger** - If you do not follow the instructions, you will cause significant casualties.

** Warning** - If you do not follow the instructions, you will cause serious casualties.

**Other important information is listed under the following headings:**

**Notes** - Information to help you avoid damage to your motorcycle, other property, or the environment.

# Contents

Motorcycle Safety .....4

User Manual .....13

Maintenance .....36

Fault Handling .....70

Relevant Information .....80

Technical Parameters .....91

# Motorcycle Safety

This section contains important information about the safe riding of motorcycles, please read this section carefully.

Safety Instructions .....	5
Safety Precautions .....	8
Riding Precautions.....	9
Spare Parts and Modifications .....	12
Loading Guide .....	12

## Safety Instructions

To enhance your driving safety, please follow these guidelines:

- Perform all routine and routine inspections as specified in the Instruction Manual.
- Before filling the tank, turn off the engine and keep away from sparks and open flames.
- Do not start the engine for a long time in a closed or semi-closed space, because the exhaust gas contains carbon monoxide, which is a toxic gas and can be fatal.

### Always wear a helmet

It has been proven that helmets and protective clothing can significantly reduce the chance of injury to the head and other parts, and reduce the degree of injury. Therefore, please be sure to wear a certified motorcycle helmet and protective clothing when driving.

### Before the ride

Make sure you're in good physical condition, paying attention, and not drinking or taking medication. Make sure that you and your passengers are wearing a certified motorcycle helmet and protective clothing. Make sure your passenger to hold onto the rear grab handle or hold your waist, place his/her feet on the pedals, and lean with you when you turn, even when the motorcycle is stopped.

### Take time to study and practice

Even if you have driven other motorcycles, you should practice riding this motorcycle in a safe area to familiarize yourself with the operation and operation of this motorcycle and adapt to the size and weight of the motorcycle.

### Have a sense of protection when riding

Always pay attention to the vehicles around you, do not think that other drivers can see you, always be prepared to make emergency brakes or avoid detours.

### Make yourself easier to see

Especially at night, wear bright reflective clothing to make yourself more eye-catching, stop so that other drivers can see you, turn on the signal light before turning or changing the lane, and when necessary, use the horn to remind pedestrians.

### Don't drink and ride

Alcohol and driving are not compatible. Never exceed your personal ability when driving, and do not exceed the speed specified by the vehicle, fatigue and negligence will weaken your ability to make correct judgments and safe driving.

### Keep your motorcycle in a safe state

It is important to take good care of your motorcycle so that your motorcycle is always in good condition. Check your motorcycle before each ride and complete all recommended maintenance and repairs. **Do not modify motorcycles or add accessories that will affect safety without authorization, and overload is strictly prohibited.**

### Dealing with incidents

Your personal safety is your first priority. If you or anyone else is injured, you should first carefully evaluate the severity of the injury and determine whether it is safe to continue driving, and call for emergency assistance if necessary. If other persons or vehicles are involved in a collision, the applicable local laws and regulations should also be followed.

If you decide to continue driving, first power the electronic ignition lock off, and then evaluate the condition of the motorcycle. Check whether there is oil leakage, check whether the key nuts and bolts are fastened, and check the steering handle, steering column, brake and wheel to ensure that the personnel and vehicle are safe. Please drive slowly and carefully. Your motorcycle may have suffered damage that will not be immediately apparent, please submit it to a special repair shop or a qualified special repair shop of KOVEMOTO for a thorough inspection as soon as possible.

## Carbon monoxide hazard

The exhaust gas contains toxic carbon monoxide, a colorless and odorless gas, and inhaling higher concentrations of carbon monoxide can cause people to lose consciousness and may even be fatal.

Do not start the engine for long periods of time in a garage or other enclosed space.

### **▲ Warning**

- If the engine is started for a long time in a closed or semi-closed space, it may cause a rapid accumulation of toxic carbon monoxide gas.
- Inhaling this colorless, odorless gas causes rapid loss of consciousness and death.
- Motorcycle engines should only be started in well ventilated outdoor areas.

## Safety Precautions

- Be careful when riding, always keep your hands on the throttle grips and your feet on the pedals.
- Make sure that the passenger grasps the grab handle or hugs your waist while driving, and puts his/her feet on the pedals.
- Always pay attention to the safety of riders, passengers and other drivers on the road.

## Protective clothing

Make sure that you and any accompanying passenger are wearing a certified motorcycle helmet, goggles and eye-catching protective clothing, and drive carefully according to the weather and road conditions.

### ■ Helmet

It is certified to safety standards, eye-catching, and sized to fit your head size.

- It must be safe and comfortable and secured with a chin strap.
- It does not obstruct the line of sight of the mask or other certified goggles.

### ■ Gloves

High-wear-resistant full-finger leather gloves.

### ■ Boots or riding shoes

Boots that are strong and slip-resistant and protect the ankle.

### ■ Clothing

It includes a protective eye-catching long-sleeved shirt suitable for riding and wear-resistant pants (or protective suits).

## ▲ Warning

- Not wearing a helmet increases the chance of serious injury in an accident.
- Make sure that you and your passengers always wear certified helmets and protective clothing.

## Riding Precautions

### Run-in period

Follow these guidelines during the first 1000 km of driving to ensure the motorcycle's later reliability and performance.

- Avoid full throttle start or rapid acceleration.
- Avoid emergency braking and rapid downshifting.
- Ride carefully.

### Brake

**Follow the following guidelines:**

- Avoid excessive emergency braking and downshifting
  - ▶ Sudden braking will reduce the stability of the motorcycle.
  - ▶ Slow down before turning, or you may slip.
- Be careful when driving on slippery roads
  - ▶ Tyres are easier to slide on slippery surfaces and require longer braking distances.
- Avoid continuous braking
  - ▶ In the long and steep slope down the slope, repeated braking will lead to serious overheating of the brake, affecting the braking effect. You should use the engine brake and use the brake intermittently to slow down.
- The front and rear brakes can be used at the same time to achieve a complete braking effect.

## ■ Anti-lock brake system (ABS)

This model is equipped with an anti-lock braking system to prevent tire lock-up during emergency braking.

- When the vehicle speed is less than 5 km/h, the anti-lock braking system does not work.
- During braking, after ABS intervention, the brake handle or Foot brake lever may slightly rebound, which is a normal phenomenon.
- Always use the recommended tyres to ensure that the anti-lock braking system works correctly.

## ■ Engine brake

When you release the accelerator, the engine braking will help the motorcycle slow down. If you want to slow down further, you can downshift to a lower gear. When going downhill on a long and steep slope, you should use engine braking and apply the brakes intermittently to slow down.

## ■ A humid and rainy environment

In a wet and rainy environment, the road surface will be wet and slippery, and the wet brake will also reduce the braking efficiency. You need to be very careful when braking. If the brake is wet, it can be intermittently repeated during low-speed driving and riding, which helps to dry the brake quickly.

## Parking

- Stay on solid, flat ground.
- If you must stop on a slightly inclined or loose ground, make sure to stop the motorcycle and make sure that the motorcycle cannot move or tip over.
- Ensure that high temperature parts do not come into contact with flammable materials.
- Do not touch the engine, muffler, brake and other high temperature parts before cooling.
- To prevent the possibility of theft, always ensure the motorcycle is powered off and the steering is locked before leaving a motorcycle unattended.

## Stop the motorcycle with the side support

1. Extinguish engine.
2. Lower side support.
3. Tilt the motorcycle slowly to the left until its weight is concentrated on the side bracket.
4. Turn the steering handle completely to the left.
  - ▶ If the steering handle is turned to the right, it will reduce stability and may cause the motorcycle to fall.
5. Long press the electronic ignition lock button until it powers off and enters the steering lock state.

## Fueling/brake fluid and fuel guide

Follow these guidelines to protect your engine and catalytic converter:

- Use only unleaded gasoline.
- It is recommended to use high octane gasoline. The use of low octane gasoline will reduce the performance of the engine.
- It is not recommended to use ethanol gasoline, which will reduce the performance of the engine.
- Do not use spoiled or contaminated gasoline, or oil-gasoline blends.
- Prevent dirt and water from entering the tank.
- Since the brake fluid has a certain corrosive effect, be sure to avoid splashing into the eyes, adhering to the skin and avoiding contact with nonmetallic materials of the vehicle when adding.

## Spare Parts and Modifications

We strongly recommend that you do not use any accessories other than KOVEMOTO, and do not modify the original design of the motorcycle, which will cause the motorcycle to be unsafe. Unauthorized modifications to your motorcycle will void your warranty service and result in your motorcycle being unable to legally drive on public roads and highways. Before you decide to add accessories to your motorcycle, first determine which modifications are safe and legal.

**It is prohibited to attach a trailer or a sidecar to a motorcycle and to modify or install other equipment at the engine installation point. Your motorcycle does not have the design of these accessories, and their use will seriously damage the maneuverability and safety of the motorcycle.**

### ▲ Warning

- Improper accessories or modifications may cause safety accidents, in which you may be seriously injured or even life-threatening.
- Please follow all instructions in the Instruction Manual for accessories and modifications.

## Loading Guide

- The additional load will affect the maneuverability, braking and stability of the motorcycle. When riding with heavy loads, be sure to maintain a safe speed.
- Please stay within the specified loading limit. The payload of the vehicle is 175kg. Do not overload it.
- Fix all luggage and place it evenly and smoothly near the center of the motorcycle.
- Do not place objects in the headlights or Mufflers.

### ▲ Warning

- Overloading or improper loading will lead to accidents, resulting in serious casualties.
- Please follow the loading instructions in the Instruction Manual.

# User Manual

This section contains important information about the operation of the motorcycle, please read this section carefully.

Parts Location Diagram .....	14
Instruments .....	18
Handlebar Switch .....	27
Electronic Ignition Lock .....	29
Start the Engine .....	31
Gear Shifting.....	32
Front Windshield Adjustment .....	33
Traction Control System .....	34
Refueling .....	35

Component Location Diagram - Standard

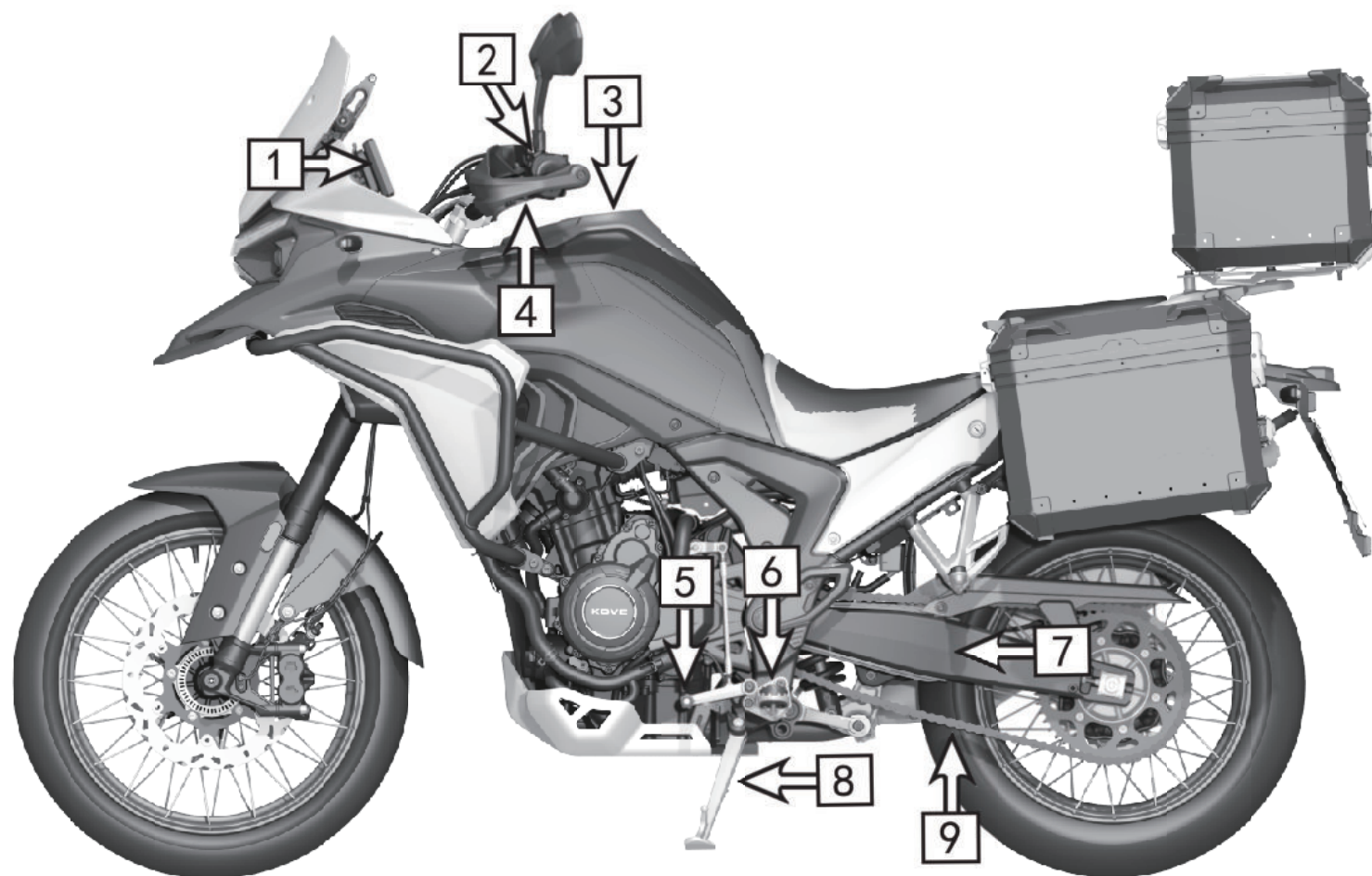

1.Instrument assembly 2.Handlebar switch-left 3.Fuel tank lock 4.Clutch lever 5.Shift pedal 6.Front footpeg assembly-left  
7.Swingarm 8.Side stand 9.Chain

Component Location Diagram - Standard

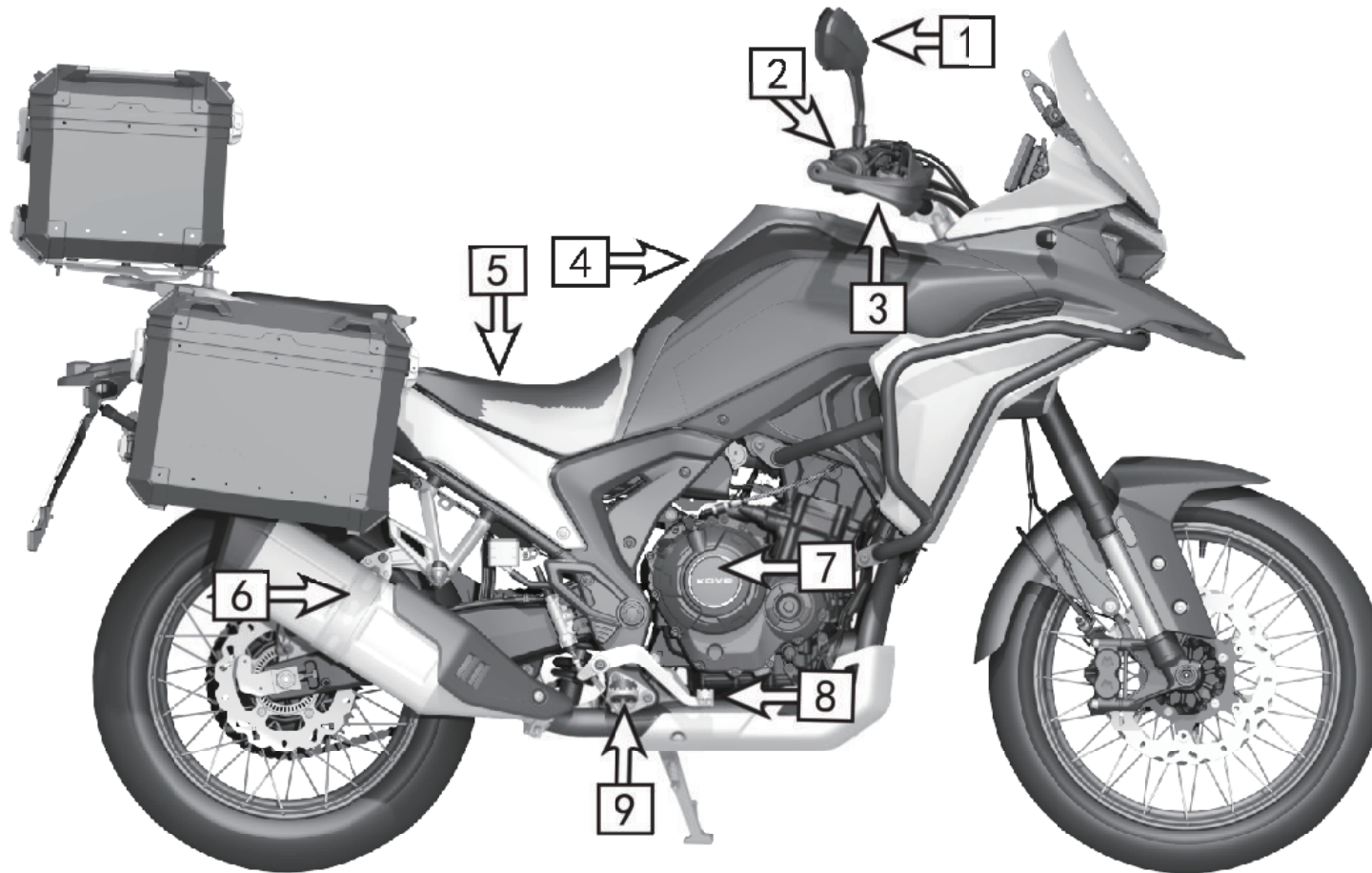

1.Rear view mirror 2.Handle switch-right 3.Front brake lever 4.Fuel tank 5.Front seat cushion 6.Muffler 7.Engine 8.Rear brake pedal 9.Front footpeg assembly - right

Component Location Diagram - High Configuration

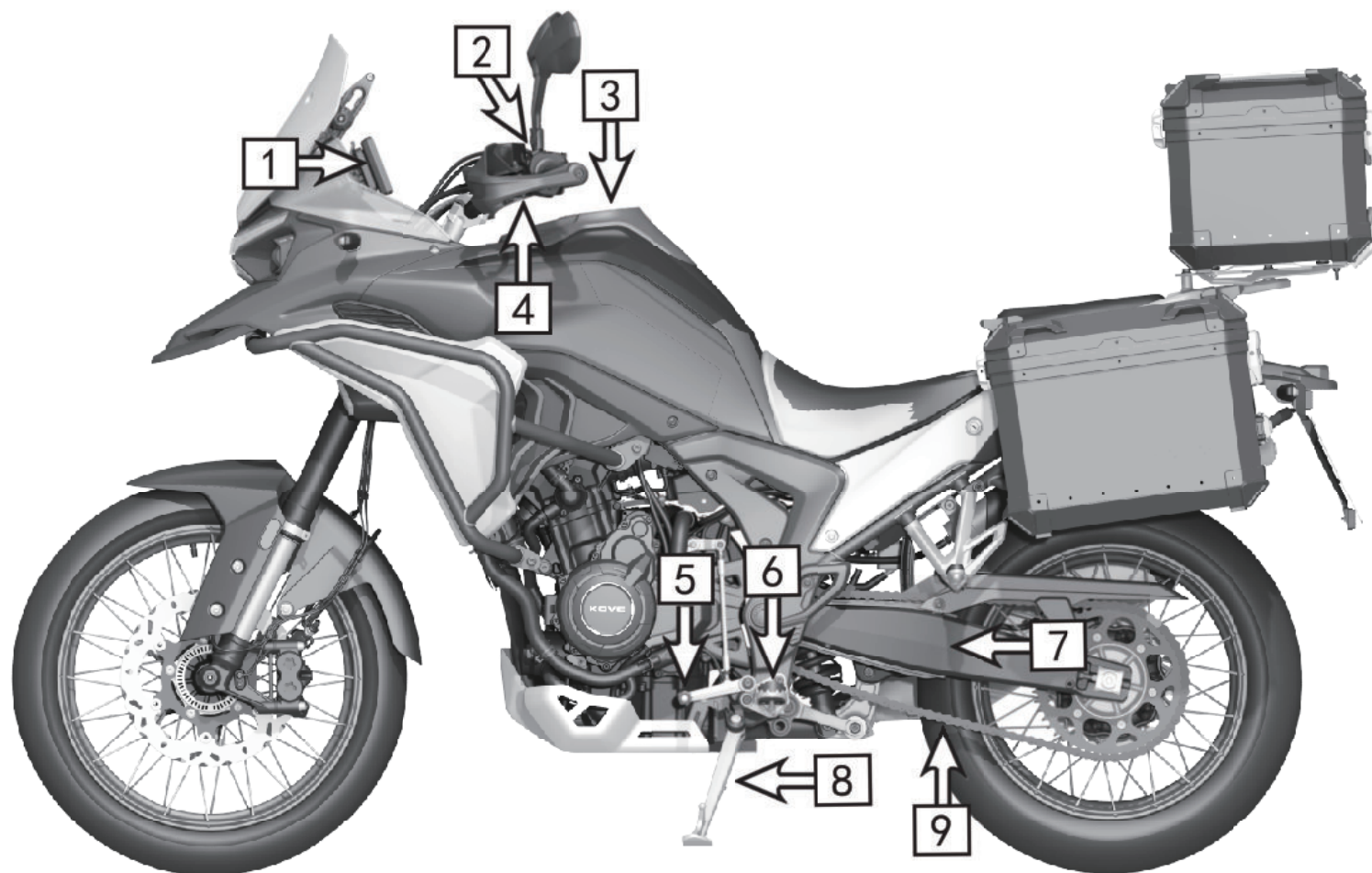

1.Instrument assembly 2.Handlebar switch-left 3.Fuel tank lock 4.Clutch lever 5.Shift pedal 6.Front footpeg assembly-left 7.Swingarm 8.Side stand 9.Chain

Component Location Diagram - High Configuration

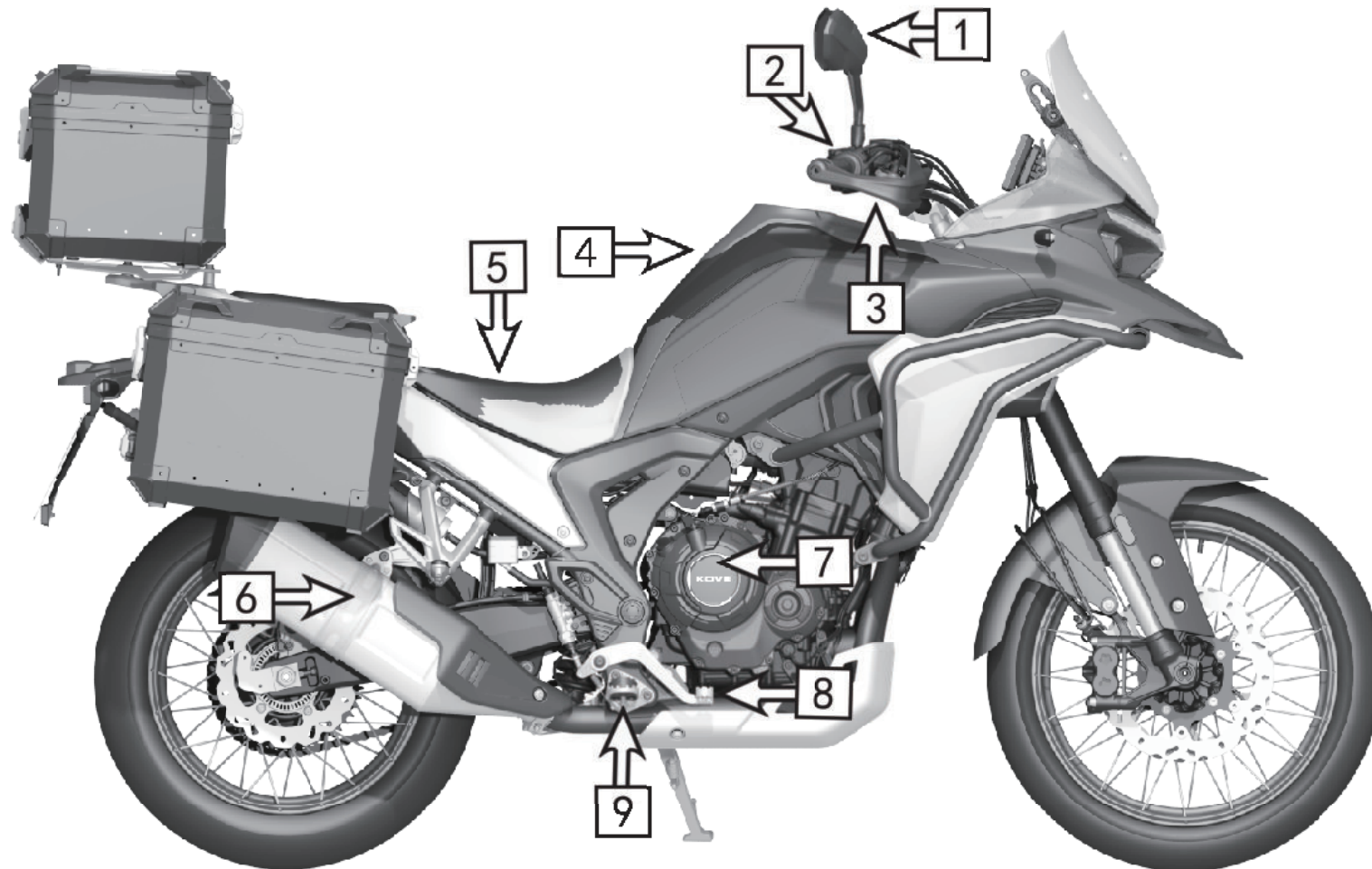

- 1.Rear view mirror 2.Right combination switch 3.Front brake lever 4.Fuel tank 5.Front seat cushion 6.Muffler 7.Engine  
8.Rear brake pedal 9.Front footpeg assembly - right

## Instruments

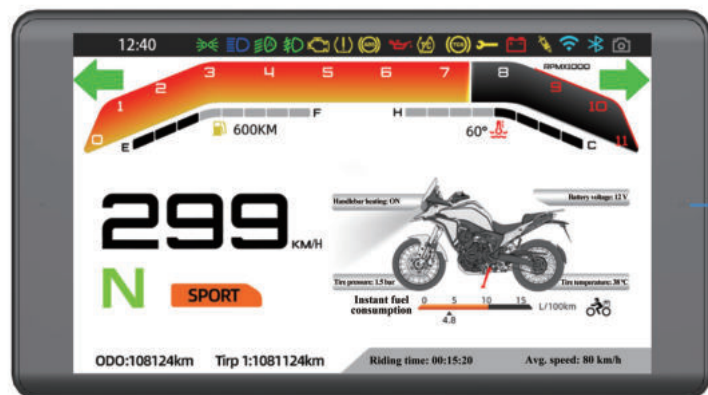

Light-sensitive hole

### Display check

When the electronic ignition switch is powered on, the instrument is powered on to play the start-up animation, and then self-test is performed, and all functional modules and symbols are displayed. If the display is missing during self-test, please visit KOVE authorized repair shop for inspection as soon as possible.

### Notes

- Due to differences in display icons across versions, the interpretation of various functions can be referenced to the model introduction of the High Configuration.

## Instrument Interface Description (High Configuration) - 1

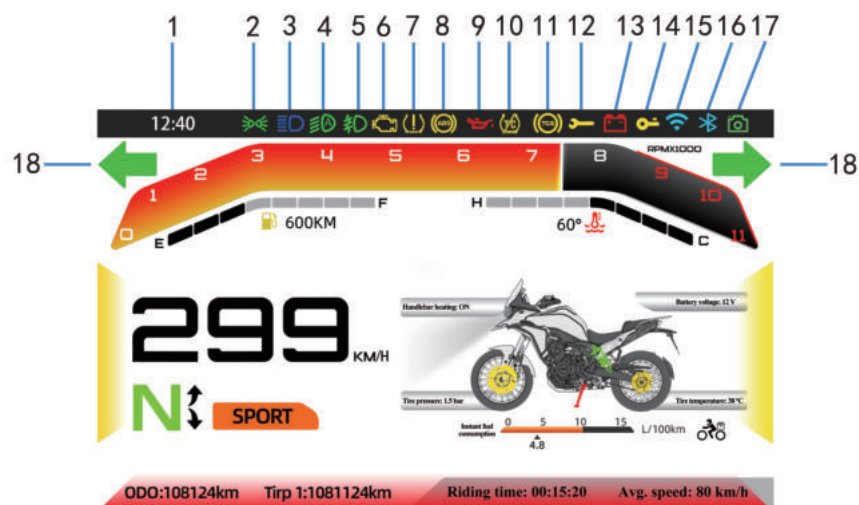

S/N	Name	Functional Description
1	Time display	Displays the instrument time
2	Position indicator light	After the vehicle is powered on, the indicator will illuminate once the position lamp is on.
3	High beam indicator	When the high beam is switched on, this light is ON
4	Automatic headlights	Display headlight mode: " " for Automatic Headlights, " " for Always On.
5	Fog lamp indicator	When the fog lamp is switched on, this light is ON
6	Electronic injection malfunction indicator light	When the electronic fuel injection system fails, this light is ON (after the engine is powered on, the light illuminates. After the normal start, this malfunction indicator goes out as a normal phenomenon)
7	TP warning	When the tire pressure data is abnormal, this light illuminates

S/N	Name	Functional Description
8	ABS malfunction indicator light	① When a fault occurs, this light is ON; ② After the whole vehicle is powered on, this lamp flashes as a normal phenomenon (0.5S on, 0.5S off). When the vehicle speed is > 5km/h, the ABS self-test is extinguished immediately after passing.
9	Oil pressure indicator	When the oil pressure is insufficient, this light is ON
10	TCS off indicator	When TCS Function is Deactivated: indicator On
11	TCS malfunction indicator light	① When TCS malfunctions: the indicator remains lit (it is normal for this indicator to stay on after the vehicle is powered on; when the vehicle speed exceeds 5 km/h, the indicator extinguishes once passing the self-test; ② When TCS Intervenes, the indicator flashes.
12	Service indicator light	When the motorcycle reaches the maintenance setting condition, this lamp is ON
13	Low battery voltage indicator	When the battery voltage is too low; this light is ON
14	Smart key indicator	When the smart key malfunctions or the battery is too low, this light is ON
	Electronic suspension malfunction indicator	This light comes on when the electronic suspension fails.
15	WIFI display	When connected to WIFI, this light is ON
16	Bluetooth display	When connected to Bluetooth, this light is ON
17	Dashcam indicator light	When the dash cam is open, this light is ON
18	Turn indicator light	The left turn indicator flashes when the left turn signal is ON The right turn indicator flashes when the right turn signal is ON When the warning indicator is ON, the left and right turn indicators flash simultaneously

## Instrument Interface Description (High Configuration) - 2

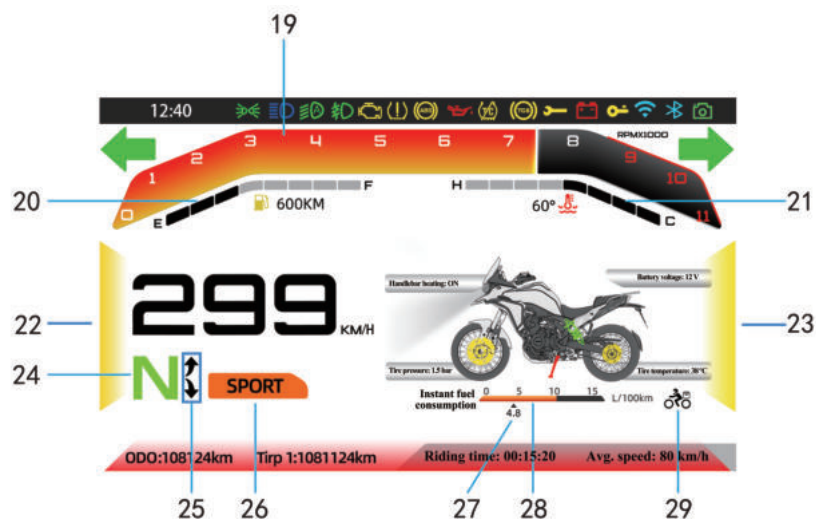

S/N	Name	Functional Description
21	Water temperature display	① When the water temperature indicator block displays red and lights up the “water temperature alarm lamp”, it means that the water temperature is too high. In the case of ensuring safety, stop for inspection, and continue driving after the water temperature drops; ② When the water temperature data is abnormal, all water temperature blocks and icon simultaneously flash
22	Left radar warning display	When a vehicle approaches rapidly from the left rear: Standard Alarm: The left side of the instrument displays yellow and flashes Enhanced Alarm: The left side of the instrument displays red and flashes
23	Right radar alarm display	When a vehicle approaches rapidly from the right rear: Standard Alarm: The right side of the instrument turns yellow and flashes Enhanced Alarm: The right side of the instrument displays red and flashes
24	Gear indicator	Display the current gear
25	Gear shift indicator	When the shift prompt is currently active, the shift indicator light flashes.
26	Riding mode	ECO is displayed in economy mode, SPORT is displayed in sport mode
27	Trip average fuel consumption	Displays the average fuel consumption value for the sub-total mileage with a refresh time of 30s.
28	Instant fuel consumption display	① When the vehicle speed is $\leq 3$ km/h, it is displayed as 0; when the fuel exceeds the maximum value, the maximum value is displayed; ② When no signal is detected for 3 consecutive seconds, it is displayed as 0;
29	Electronic suspension preload settings display	Display pattern: ① Single rider (default) ② Single rider + load (25KG) ③ Two-person ride ④ Speed-adaptive highway

S/N	Name	Functional Description
19	Tachometer	Engine speed display
20	Fuel display	Displays oil level of fuel ① When the oil level is lower than 1 bar (after a period of continuous use, the red oil level will flash at the same time as the oil level symbol), please replenish the fuel as soon as possible; ② If the fuel symbol and oil level flash simultaneously, it indicates abnormal oil level signal. Please visit KOVE authorized repair shop for inspection as soon as possible; ③ The driving range calculation result is affected by many factors such as vehicle working conditions and ride habits. The display data is for reference only.

### Instrument Interface Description (High Configuration) - 3

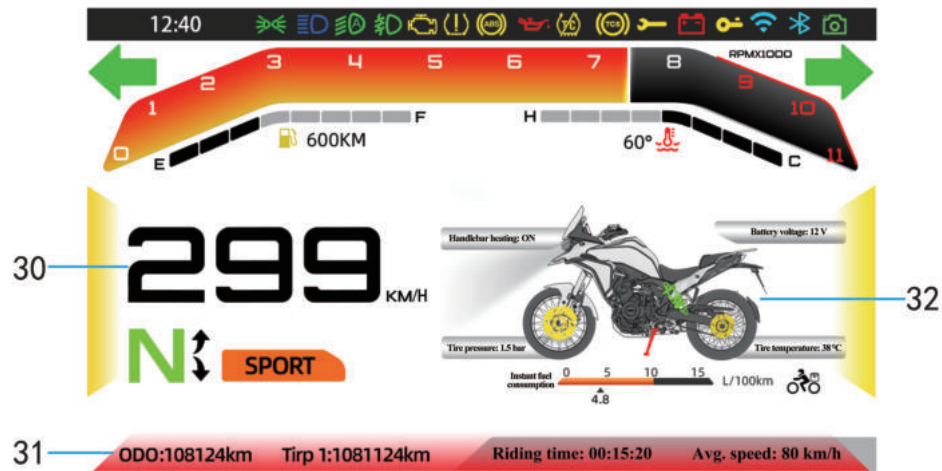

S/N	Name	Functional Description
30	Speedometer	Display the current speed
31	Riding information and rear radar collision warning display	① Display the total riding mileage, sub-total mileage, riding time, average vehicle speed, and other information; ② When the radar detects a vehicle approaching rapidly from behind with a risk of collision, the display below the instrument turns red and flashes.
32	Vehicle information and mode display	① Displays information such as vehicle handlebar heating, seat heating, battery voltage, tire pressure, and tire temperature. Altitude and weather data require a connection to a mobile phone with the KOVE APP installed to be displayed. ② Electronic rear shock absorber mode display The highway mode shock absorber icon is displayed in green. The all-terrain mode shock absorber icon is displayed in orange ③ ABS mode display Front and rear brake calipers/discs display gray: ABS on front and rear wheels enabled Front and rear brake calipers/discs display yellow: ABS on front and rear wheels disabled Front brake calipers/discs display gray, rear brake calipers/discs display yellow: Rear-wheel ABS only disabled ④ Side stand indicator Lower the side stand, then the side stand indicator light turns on. Raise the side stand, then the side stand indicator light turns off.

## Menu Instructions-1

Level 1 Menu	Level 2 Menu	Level 3 Menu	Description
Riding mode	Engine mode	ECO	Sets the engine power output mode. SPORT: Sport mode; ECO: Economy mode.
		SPORT	
	ABS mode	Fully ON	Set the ABS working status, and the current ABS working status is displayed through the instrument icon.
		Rear wheel disabled	
		Front&Rear wheel disabled	
	TCS mode	Enable	Users can choose TCS ON, TCS OFF functions (Note: Selecting TCS OFF will disable the TCS-assisted driving function. Please choose carefully)
Close			
Power-saving settings (high configuration)	Preload status/damping mode	Highway seat height custom	① The user can select different preload states and damping modes for combined use; ② The preload height is factory default; the user can adjust the seat height to a suitable level according to their needs (except for highway speed-dependent adjustment); ③ About seat height customization: Adjustment range: 795mm~820mm; Adjustment method: After selecting the seat height to be adjusted, press the "Confirm" button twice until the background color turns red, then use the "Up/Down" buttons to adjust to the appropriate seat height; ④ The highway speed-dependent adjustment mode can only be set in the parked state; ⑤ To prevent the power unit motor from overheating, do not frequently set the electronic suspension mode, as this may cause irreversible damage.
		All-terrain seat height custom	
		Highway speed-dependent adjustment	
Heating system	Heating level/heating unit	Handlebar heating	① The heating gear includes an Off setting and 3 adjustable gears; the user can select the appropriate heating gear according to their needs. ② Click the left and right button to cycle through the handlebar heating gears, and click the down button to cycle through the seat heating gears.
		Seat heating	

## Menu Instructions-2

Level 1 Menu	Level 2 Menu	Level 3 Menu	Description
Vehicle settings	Gear shift prompt	Restore to factory settings	Users can set the shift prompt RPM conditions themselves (restore factory settings: the default setting is 5500 RPM for upshifts and 2500 RPM for downshifts).
		Custom	
		Close	
	Headlight mode	Automatic headlights	When this function is selected, the instrument will automatically control the brightness of the headlights based on ambient light conditions
The headlights are always on		When this function is selected, the headlights remain lit after the engine is started	
Connection settings	WiFi connection	/	Set up and reset bluetooth/WIFI connection with the phone (to ensure normal connection, the dedicated APP on the phone needs to enable permissions as prompted; when using WIFI connection, do not choose to use instrument WIFI for internet access, otherwise it will affect the phone's internet function)
	Bluetooth connection	/	
	Reset connection	/	
Dvr recording (high configuration)	Start recording	/	<p>① In the recording settings, you can select Start Recording, Stop Recording and Delete Local Videos; among these options, Delete Local Videos will format the storage, and this operation will result in the loss of all videos, which is irreversible;</p> <p>② The instrument is equipped with built-in 32G EMMC storage and does not support memory card expansion; after the recording starts, a video file will be saved every 3 minutes; when the storage is full, new video files will automatically overwrite old ones.</p> <p>③ You can view the current camera through the front view on the DVR display. Open the KOVEMOTO Motorcycle APP, scan the QR code on the projection interface to successfully connect to the instrument, then you can download the required video files.</p> <p>Users can choose the day and night UI mode that has been used according to their preferences, and the factory default is automatic</p>
	Stop recording	/	
	Delete local video	/	
Instrument settings	Display setting	/	Users can choose the day and night UI mode that has been used according to their preferences, and the factory default is automatic
	Brightness settings	/	Users can select their preferred screen brightness level; Select Auto or low brightness level to turn on the welcome light; select the medium brightness or high brightness to turn off the welcome light.

### Menu Instructions-3

Level 1 Menu	Level 2 Menu	Level 3 Menu	Description
Instrument settings	Time settings	/	Set the instrument panel display time (if Auto Update is selected, the time will be automatically synchronized with the mobile phone after Bluetooth connection is established).
	Language settings	/	Switch between Chinese/English/Spanish
	Unit settings	/	Set the unit conversion for vehicle speed, tire pressure, and temperature
Vehicle information	Tire pressure information	Single-wheel matching	The user can set the tire pressure alarm limit. The factory default settings are: an alarm will be triggered if the front or rear tire pressure falls outside the range of 1.9 bar to 2.9 bar, or if the tire temperature exceeds 70°C.
		Alarm threshold	
		Sensor id	
	Maintenance information	/	① The first maintenance mileage is at 1000m or 1 year. This default parameter cannot be modified. After that, users can set the maintenance reminder cycle according to their actual needs. ② The maintenance reminder can only be cleared after meeting the conditions for the first guarantee. Adjustment range: 3,000–6,000 km / 30–365 days; adjustment step: 200 km / 10 days. ③ Maintenance Reminder Clearance Method: When the cursor is on the maintenance information-Level 3 Menu, long-press the "Confirm" button to clear the maintenance mileage; the maintenance indicator light will turn off and the system will enter the next maintenance cycle.
	Vehicle diagnostics	/	Display ECU malfunction, ABS malfunction, BCM malfunction
Instrument version	/	Display panel version	

#### Notes

- Icon Filling: ① Gray indicates the selection mode before settings; ② White indicates the current cursor position; ③ Fill with blue after selecting "Confirm".
- Use Up/Down buttons for left-right menu cycling.

**The instrument functions are as follows:**

**Menu switch:**

Press the ENT key briefly to enter the main menu; press the up and down keys briefly to scroll through pages; long-press the down key to reset the Sub-total Mileage data.

**Information viewing:**

When the mobile phone is connected with Bluetooth, the message display panel will reflect the information pushed by the mobile phone. Press the SET key to view the details, and press ESC key to clear it.

**Function setting:**

Press the ENT key to enter the instrument menu. Parameters such as riding mode, handlebar/seat cushion heating, headlight mode, instrument brightness, time, and language can be configured via the human-machine interaction menu.

**Instrument and mobile phone interconnection:**

1.The positioning function, navigation function, information push function, weather function, automatic time function, altitude display and other functions in the TFT instrument can only be realized after interconnection with the mobile phone installed with the relevant APP.

2.Steps to install the phone APP: ① Enter Main Menu settings; ② Select connection settings; ③ Use a phone connected to the internet to scan the "WIFI connection" on interface, then download and install the APP as prompted; ④ Enable the phone bluetooth/WIFI to realise the interconnection with the instrument (for optimal user experience, please refer to the APP usage guide when using the phone APP).

3.When the instrument needs to be disconnected from the phone, enter the phone setting menu and select Disconnect Bluetooth/Disconnect WIFI.

Notes

- If you need to modify the riding mode or electronic suspension mode, it must be conducted while the vehicle is parked.

## Instrument Angle Adjustment

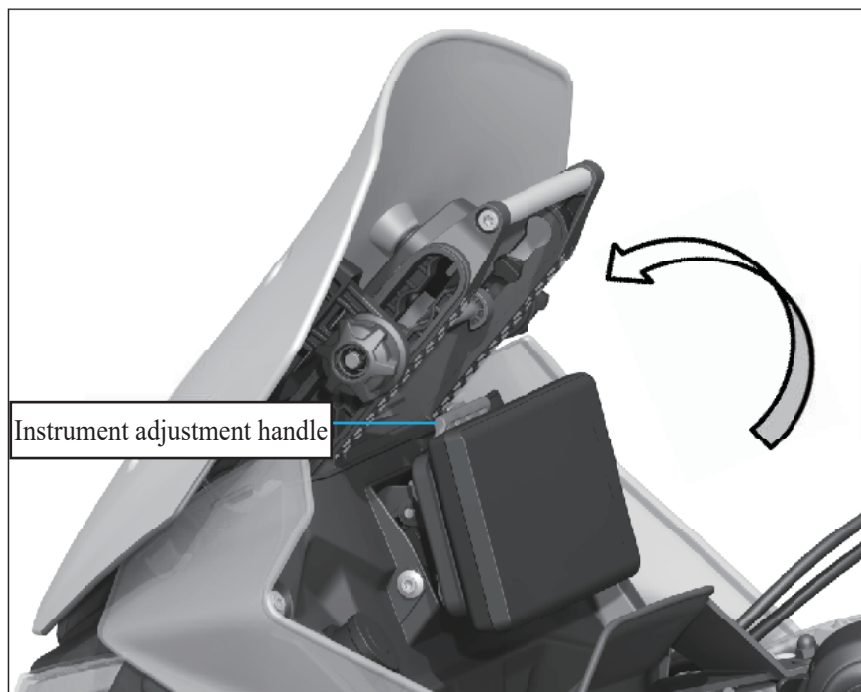

The instrument adjustment base is equipped with multiple fixed grooves. By pressing the adjustment handle, you can adjust the instrument to your preferred angle.

### **⚠ Warning**

- The instrument angle should be adjusted when the motorcycle is stationary, and must not be operated while in motion.

## Handlebar Switch

### Instrument Angle Adjustment

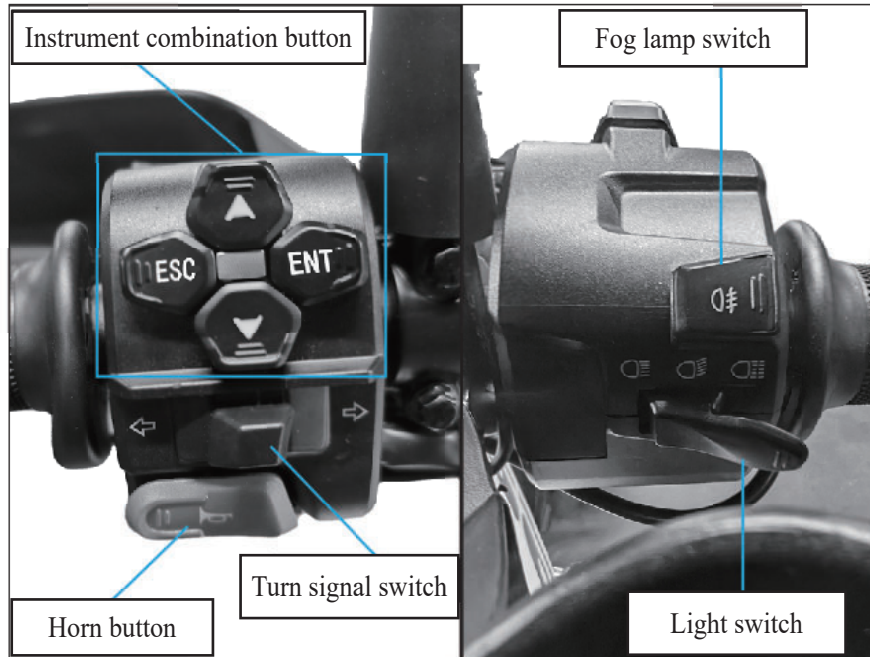

**Menu switch:** This combination button is used to set different functions of the instrument.

▲▼ : Switch up and down

▲▼ : Select to switch Up and Down

ESC: Back button

ENT: Confirm/Menu button

### Horn button:

📣 Press this button to sound the vehicle's horn.

### Turn signal switch:

⬅️ Turn on the left turn signal: toggle the switch to the left, and the turn signal switch returns to its original position after operation.

➡️ Turn on the right turn signal: toggle the switch to the right, and the turn signal switch returns to its original position after operation.

OFF Turn off the turn signal: When the turn signal switch is in the middle position, press this button to turn off the turn signal.

### Fog lamp and lighting switches:

The fog lamp and light switch are located on the back of the handlebar switch. The fog lamp function has three modes: fog lamp mode, high-brightness mode, and flashing mode (the instrument panel displays the fog lamp indicator icon, but does not show mode switching). Long press the fog lamp switch to cycle through the modes, and the fog lamp will flash twice to indicate successful mode switching.

☰ Turn on the headlight flasher

☰ Turn on the high beam

☰ Turn on the dipped beam

☰ Fog lamp switch

## Right Combination Switch

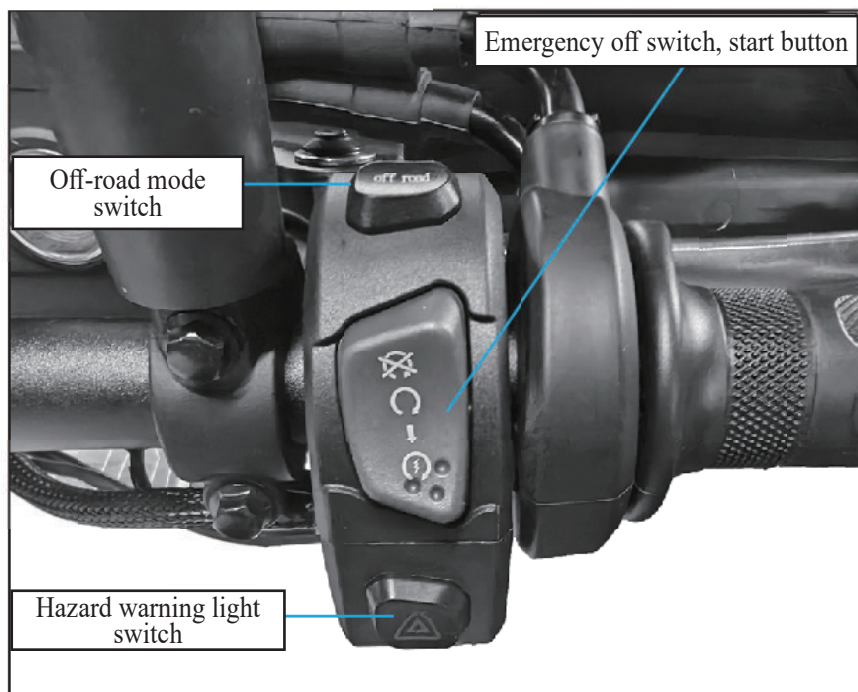

### Hazard warning light switch:

△ After the emergency button is pressed, the left and right turn signal lamps flash at the same time.

### Notes

- To extend the lifespan of the switch, it is recommended to blow out any accumulated water inside the switch after car washing or heavy rain.

### Emergency OFF switch:

Only when the switch is in "○"(ON) position, the engine can be started;

When the switch is in "⊗"(OFF) position, the engine cannot be started.

- In case of emergency, switch to the "⊗" (stop) position to extinguish the engine.

### Electric starter button:

When the OFF switch is set to "○" position:

- ① If the engine is in neutral, press the "⊕" button to start the engine.
- ② If the engine is not in neutral, users should retract the side stand and squeeze the clutch handle, then press the "⊕" button to start the engine.

### Off-road mode switch:

- ① The off-road switch has higher priority than the riding mode set on the instrument panel.
- ② Press the switch briefly, and an alert "Please confirm whether to enable Off-Road Mode" will pop up on the instrument panel; press the Confirm button to activate Off-Road Mode, or press the Return button to cancel the operation.
- ③ Press the switch briefly again to close the off-road mode and restore the previous mode.
- ④ After enabling off-road mode, ECU: Sport; ABS: Front&Rear wheel disabled; TCS: OFF; Electronic suspension: all-terrain

## Electronic Ignition Lock

### PKE Lock Body

This motorcycle features a one-touch electronic ignition lock. Simply bring the smart remote key near the vehicle and press the electronic lock button to power on the entire system.

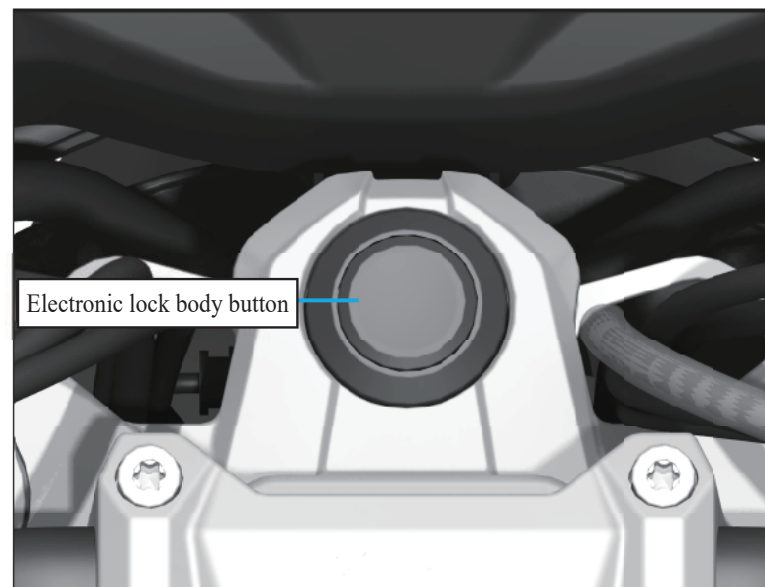

Initial state	Lock body button	Steering lock release + power on	Power on	Power off	Steering locked	Lock indicator light color		Additional notes
						Success	Failure	
Steering locked	Short press/Long press	√				/	/	Condition description: 1. The power of both the vehicle and key is normal; 2. Detection range < 1.8 M.  The remote key is within the sensing range
Power off state	Short press		√			Blue	Yellow light flashes three times	The remote key is within the sensing range
Power on state				√		Green light on for 1.5 s	Yellow light flashes three times then turn back to blue light	Vehicle speed < 3 km/h
Power off state	Long press (>1.5 s)				√	Purple light on for 1.5 s	Red light flashes three times	Turn the steering handlebar all the way to the left (align the lock tongue with the frame lock bore);

## Remote Control Key

The remote key battery typically lasts for 2 years. When the battery is sufficiently charged, pressing the remote control button will cause the indicator light to display turquoise green. When the battery is low, pressing the remote control button will cause the indicator light to display yellow.

If the remote key battery is too low, phenomena such as reduced remote range and delayed button response may occur. It is recommended to regularly check the remote range and indicator light status, and replace the battery promptly if any abnormalities are observed.

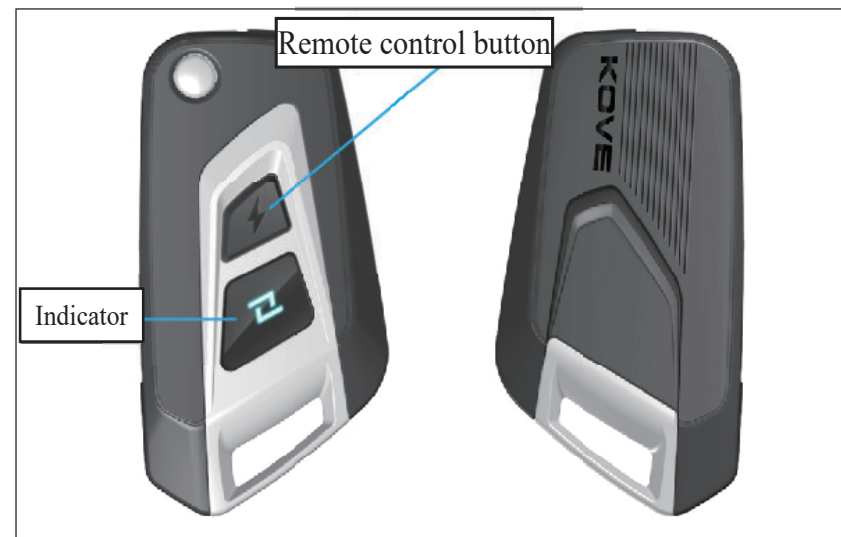

Initial State	Remote Control Button Operation Method	Steering Lock Release & Power On	Locate Vehicle & Power Off	Additional Notes
				Condition Description: 1. The power of both the vehicle and key is normal; 2. Detection range < 1.8 m.
Power Off State	Short press one time		√	Within a 50-meter range, the lock mechanism controls the vehicle's turn signal to flash three times.
Power On State	Short press one time		√	Power off the lock body; The vehicle cannot be locked if any of the following conditions are met: speed $\geq 3$ km/h, rotational speed $\geq 1000$ rpm, or missing signal; If the speed is < 3 km/h and the rotational speed is < 1000 rpm with normal signal, it can be locked.
Power Off & Steering Lock Status	Quickly short press twice	√		Within a 50-meter radius; When unlocking the steering lock, the lock mechanism controls the turn signal to flash twice; When powered on, the lock body controls the turn signal to flash 3 times.

## Notes

- During parking (including parking for a long time), the PEK lock body must be powered off or the steering locked to ensure the safety of the vehicle and prevent the battery from "losing power".
- Do not push the motorcycle while the steering mechanism is locked, otherwise it will be out of balance.

## Start the Engine

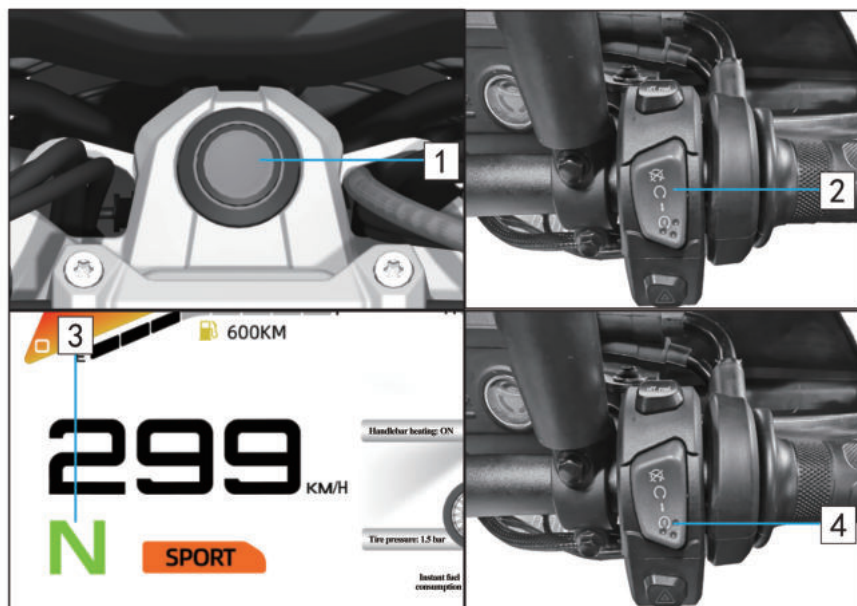

Regardless of whether the engine is cold or hot, please follow the instructions below to start the engine.

1. Open the electronic lock to the power on state.
2. Make sure that the engine switch is in the "  " (ON) position.
3. Shift the gear to neutral, or pull the clutch lever and retract the side stand, then start the motorcycle with the transmission in gear.
4. With the throttle fully closed, press the starter button to start the motorcycle.

### **If the engine fails to start:**

If the engine does not start within 3 seconds, wait for 10 seconds before repeating step 4.

### Notes

- If the engine starts but idles unevenly, slightly increase the throttle.
- Prolonged high-speed idling and rotation can harm the engine and exhaust system.
- Sudden acceleration or prolonged idling at high speed for more than 5 minutes may cause the exhaust pipe to discolor.
- If the throttle is fully open, the engine will not start.

## Shift Gears

Your motorcycle features 6 forward gears with a 1-down, 5-up shifting pattern.

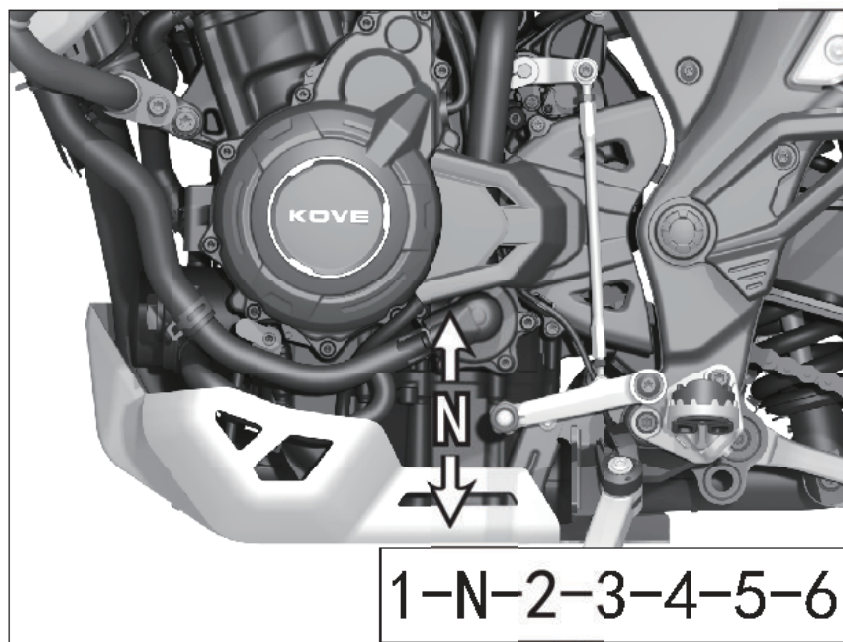

### How to shift gears:

Warm up the engine to ensure smooth operation.

1. When the engine is idling, disengage the clutch and press the gear shift pedal downward to engage the low gear (1st gear).
2. Gradually increase the engine speed while slowly releasing the clutch lever, coordinating these two actions to ensure a smooth start.
3. When the motorcycle reaches a steady riding state, reduce the engine speed, disengage the clutch, and lift the gear shift pedal to engage the 2nd gear, and so on.

### Things to pay attention to while driving:

1. Avoid unnecessary engine idling, and do not allow the engine to idle at high speeds, as this can severely damage the components.
2. Driving with the clutch partially engaged will quickly wear out the clutch plates.
3. If you feel the engine lacks power while climbing a slope, promptly shift to a lower gear.
4. While riding, especially when going downhill or at high speeds, do not use only the front brake or coast in neutral, and do not ride without holding the handlebars.
5. When stopping, reduce the throttle, disengage the clutch at the same time, and then apply the brakes.

### Front Windshield Adjustment

This motorcycle's front windshield is equipped with a height-adjustable mechanism. By simultaneously pulling the adjustment handles on both the left and right sides of the windshield bracket, you can adjust the windshield's vertical position. The windshield bracket features three sets of adjustment bores. After adjustment, ensure both left and right adjustment handles maintain the same height in a horizontal position.

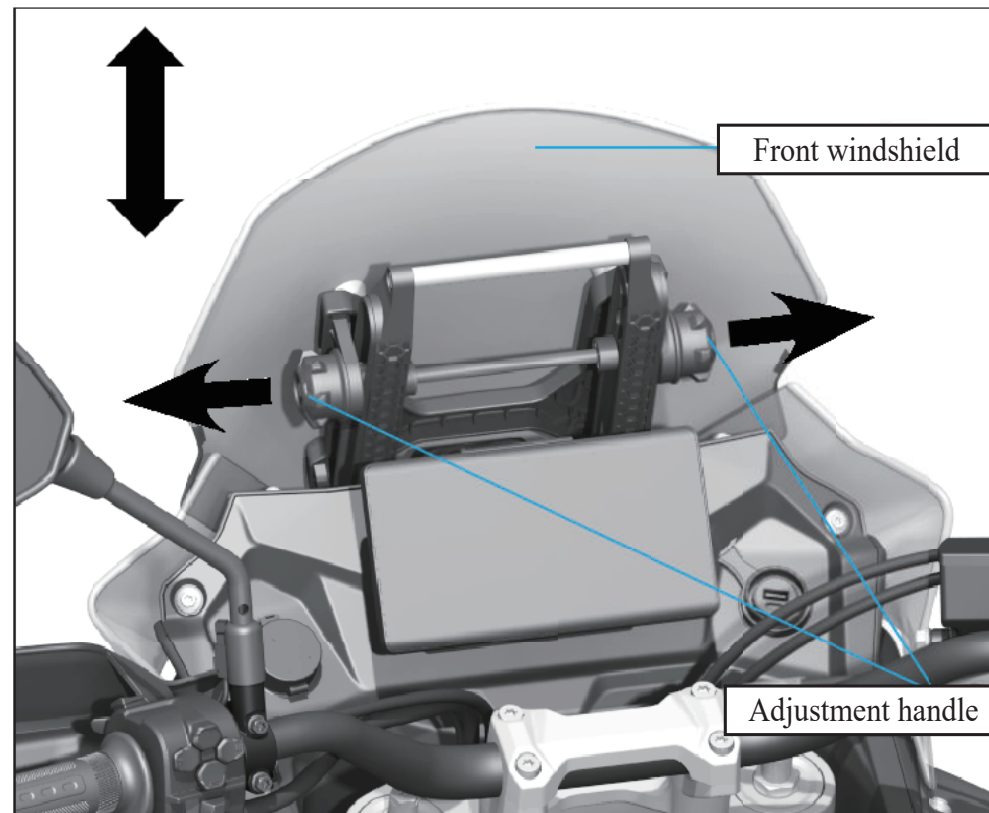

## Traction Control System (TCS)

The motorcycle is equipped with TCS (Traction Control System), which allows the motorcycle to achieve optimal traction during driving. It effectively suppresses the rear wheel slippage during starts, sudden acceleration, etc., on slippery surfaces (such as ice, snow, rain, muddy), thereby improving driving stability and safety.

You can turn the TCS function on or off through instrument settings. It is recommended to keep the TCS function on unless there are special circumstances. When TCS is turned off and the rear wheel loses grip, the system will not request torque reduction, which may cause the vehicle to yaw or crash. The rider should adjust their riding style accordingly.

On slippery surfaces, TCS will not operate due to the engine's inherent braking intervention. If you suddenly decelerate by releasing accelerator, it may cause uncontrollable rear wheel slippage. Do not suddenly close the accelerator, especially when riding on slippery surfaces.

TCS may not be able to handle rapid refueling operations on rough roads. When accelerating, please consider the road and weather conditions, as well as your skills and physical condition. If motorcycle is stuck in mud, snow, or sand, temporarily turning off the TCS can make it easier to get motorcycle out. Turning off the TCS helps maintain control and balance during off-road riding.

Always use the tire specifications, wheel speed sensors, and ring gears recommended by KOVE to ensure the TCS run properly.

When the TCS function is active, you may feel a weaker power output from the vehicle. This is normal and there is no need to worry or take any additional measures.

### Notes

- While riding, if the TCS indicator turns on, it may indicate a malfunction in the TCS function. Please power off the electronic lock and then power it back on. If the indicator still remains on after **the vehicle speed exceeds 5km/h**, it indicates an abnormality in the TCS function. Please take the vehicle to an authorized KOVEMOTO repair shop as soon as possible for troubleshooting.

## Refueling

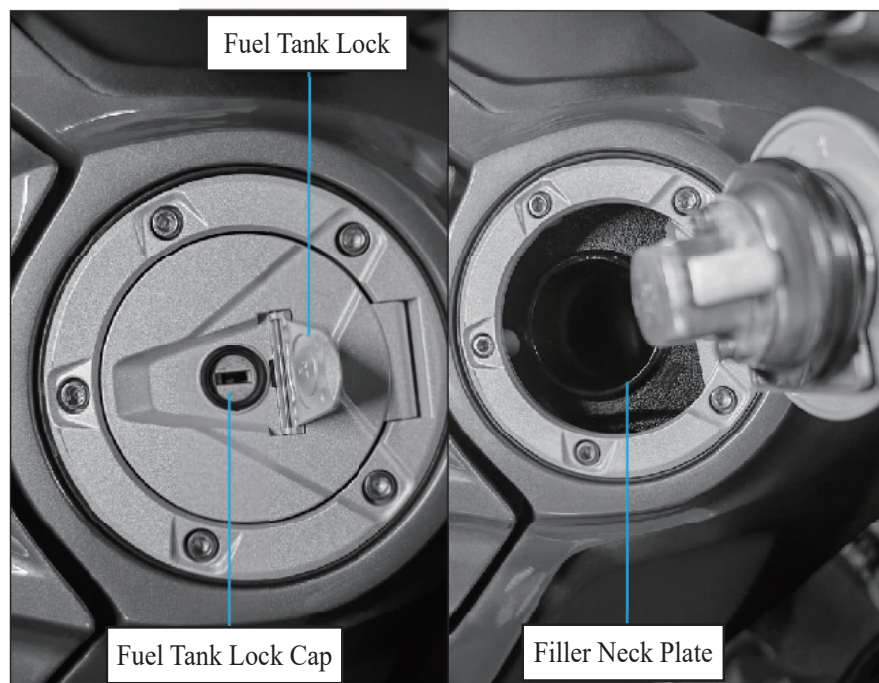

### Open the fuel tank cap:

Lift the lock cover, insert the mechanical key, and turn it clockwise to open the fuel tank cap.

### Close the fuel tank cap.

1. After refueling, press down the oil tank until it locks.
2. Remove the key and close the oil tank.

### When refueling:

After stabilizing the motorcycle with side stand, open oil tank cap for refueling. Do not refueling above the filler neck plate. The fuel tank capacity is 21 liters. The capacity of the fuel tank is 20 L. It is recommended to use 92lb or above unleaded gasoline. After the fuel is filled, close and lock the fuel tank cap..

### ⚠ Warning

- When not refueling, the fuel tank lock cover must seal the keyhole to prevent mud or water from entering the lock cylinder and causing damage.
- When refueling, always do so outdoors, ensure the engine is turned off, stay away from heat sources, sparks, or open flames, and immediately wipe up any spills.

# Maintenance

Please carefully read the "Maintenance" and "Maintenance Guidelines" sections before preparing for maintenance.

Maintenance.....	37
Maintenance Interval Table .....	38
Critical Component Torque Periodic Inspection Checklist .....	39
Maintenance Guidelines .....	40
Replacement Parts .....	41
Removal and Installation of Body Components.....	48
Engine Oil.....	51
Coolant.....	53
Brake.....	55
Side Stand.....	57
Drive Chain.....	58
Clutch.....	60
Accelerator.....	61
Front Shock Absorber Adjustment .....	62
Rear Shock Absorber Adjustment.....	65
Headlight .....	69

## Maintenance

### The Importance of Maintenance

Always maintain your motorcycle in good condition, as it is essential for your safety, protecting your property, achieving optimal performance, preventing breakdowns, and reducing air pollution.

Maintenance is a crucial responsibility for motorcycle owners. Make sure to perform checks before each ride and conduct regular inspections according to the maintenance interval table.

Please follow these guidelines during maintenance:

- Turn off the engine and switch the electronic lock to the power off state.
- Park the motorcycle on a firm and level surface using the side stand, or support it with a maintenance stand.
- Wait for the engine, muffler, brakes, and other high-temperature components to cool down before starting operations; otherwise, it may cause burns.
- Start the engine under specified conditions and ensure it is in a well-ventilated environment.

### **▲ Warning**

- Failure to perform regular maintenance before riding or to properly address faults may result in serious or fatal accidents.
- Please follow the inspection, maintenance recommendations, and maintenance interval table provided in the user manual.

### Maintenance Interval Table

The vehicle should be serviced within the specified time frame. To ensure safety, only authorized KOVEMOTO service centers are qualified for the maintenance. The meanings of the symbols in the table are as follows:

I: Inspect, clean R: Replace A: Adjust L: Lubricate

Maintenance Item		Odometer					Cycle 1 year	Notes	
		1000Km	10000Km	20000Km	30000Km	40000Km			
★	Throttle control system	I	I	I	I	I	I	After the mileage reaches 40,000 km, maintenance should be repeated at each maintenance interval starting from 10,000 km. ※ This item should be serviced by personnel from an authorized KOVEMOTO Motorcycle service center. If the user has specialized tools, repair accessories, and repair skills, they can also perform the maintenance themselves. Repair instructions can be found in this Instruction Manual. ※※ To ensure safety, this project can only be serviced by authorized maintenance personnel from an authorized KOVEMOTO Motorcycle service center. <b>Notes:</b> 1. When riding in dusty or heavily polluted areas, the air filter element should be cleaned or replaced more frequently to reduce maintenance intervals. 2. When the operating conditions are harsh, the engine oil and filter should be replaced more frequently to reduce maintenance intervals. 3. Brake pad replacement can only be performed by personnel at an authorized KOVEMOTO Motorcycle service center. 4. When the tire wears to the △ TW <sup>1</sup> mark on the sidewall or the wear limit indicator at the center of tire, it must be replaced by personnel from an authorized KOVEMOTO Motorcycle service center.	
★	Air filter element		R	R	R	R	R		Note 1
★★	Valve clearance			I/A		I/A	I		
★	Engine oil	Replace every 5000Km after the first service at 1000Km					R		Note 2
★	Oil filter element	Replace the oil at the same time					R		
	Transmission chain	Inspect or adjust after every 1,000 km, after car washing, and after riding in rainy weather or humid areas					I/A		
	Brake pad wear	I	I	I	I	I	I		Note 3
★	Brake system	I	I	I	I	I	I		
★	Clutch	I	I	I	I	I	I		
★	Fasteners		I	I	I	I	I		
★★	Steering bearing	I	I	I&L	I	I&L	I&L		
★★	Tire		I	I	I	I	I		Note 4
★★	Front and rear wheel bearings		I	I	I	I	I		
	Battery	I	I	I	I	I	I		
★★	Fuel system fuel line		I	I	I	I	I		
★★	Fuel filter		R	R	R	R	R		
★★	Spark plug		I	I/R	I	I&R	I&R		
★★	Plain fork bearing		I&L	I&L	I&L	I&L	I&L		
★★	Brake fluid		I	I	I	R	Replace every two years		
	Coolant		I	I	I	R	Replace every two years		

### Critical Component Torque Periodic Inspection Checklist

S/N	Name of Fastening Location	Recommended Inspection Material
1	Front and rear wheel axle tightening	Torque inspection is required during each maintenance cycle.
2	Upper and lower triple clamps tightening to secure the front shock absorber.	
3	Upper triple clamp and steering stem tightening	
4	Steering stem 4-slot nut tightening	
5	Steering handlebar lower clamp base tightening	
6	Engine sprocket installation tightening	
7	Engine mounting fastening	
8	Rear shock absorber fastening	
9	Fastening of cradle bolts	
10	Muffler to engine	
11	Front and rear brake caliper tightening	
12	Rear brake pump tightening	
13	Shift lever and adjustment rod end bearing tightening	
14	Brake pedal and adjusting lever end bearing tightening	
15	Entire brake line tightening	
16	Fuel rail tightening	
17	Fuel pump tightening	During each maintenance cycle inspection or replacement, perform maintenance according to the specified torque and sealing method.
18	Front and rear brake discs tightening	
19	ABS ring gear	

Note: For torque cycle inspection items not specified in this Instruction Manual, the torque standards shall be followed as per our company's "Maintenance Manual".

## Maintenance Guidelines

To ensure safety, you are responsible for performing a pre-ride inspection and making sure that any issues identified have been resolved. Pre-ride inspection is essential.

Inspection Items	Inspection Details
Handlebar	Smooth and flexible rotation, free from play or looseness
Brake system	Check its operating condition, and inspect the front and rear brake fluid levels and brake pad wear.
Fuel level	Sufficient fuel for the planned journey (refuel if necessary)
Accelerator	Check if it can open smoothly and close completely in all steering positions.
Clutch	Check its operating condition and adjust the free stroke if necessary.
Wheels/tires	Check its usage status and tire pressure, and inflate if necessary.
Drive chain	Inspect its usage condition and sag, and adjust and lubricate if necessary.
Lighting, horn	Check the lighting system and horn to ensure they are functioning correctly.
Engine oil level	Add engine oil as needed and check for leaks.
Instrument Indicators	Check if all indicators on the instrument panel are functioning properly.

## Replacement Parts

### Battery

#### ■ Inspect and replace the battery.

1. Before installing the battery, if the electrodes are found to be dirty, clean them thoroughly before installation; otherwise, poor contact may lead to malfunction.
2. If during use, the battery exhibits abnormal phenomena such as deformation, overheating, or smoking, stop using it immediately and have it inspected by an authorized KOVEMOTO Motorcycle service center.
3. If the battery is stored in a high-temperature or humid environment for an extended period, it may malfunction or experience a shortened lifespan. Before reuse, ensure the battery's appearance and functionality are normal.
4. If the vehicle fails to start, check whether the battery is functioning properly. If the battery is damaged, replace it immediately.
5. When installing the battery, ensure the battery terminal bolts are securely tightened.

#### **If the battery is not used for an extended period, please note the following:**

- To prevent over-discharge, the battery should be charged every two months.
- When the battery is not in use, it should be stored in a cool, dry environment, and the positive and negative terminals should be protected from short-circuiting.

#### Notes

- Improper handling of batteries may harm the environment and human health. Please dispose of used batteries in accordance with local environmental regulations.
- The addition of electrical appliances may cause battery drain and even electrical system malfunction.

## Fuse

Fuses protect your motorcycle's electrical circuits. If any electrical components of your motorcycle stop functioning, inspect and replace the blown fuse.

### Inspect and replace the fuses

Close the electronic lock to power it off, then remove and check the fuse. If the fuse is blown, replace it with a fuse of the same specification. Refer to the "Technical Parameters" section for the fuse Parameters.

If the fuse blows frequently, there may be a hidden issue with the electrical system. Please have it inspected by a authorized KOVEMOTO Motorcycle service center.

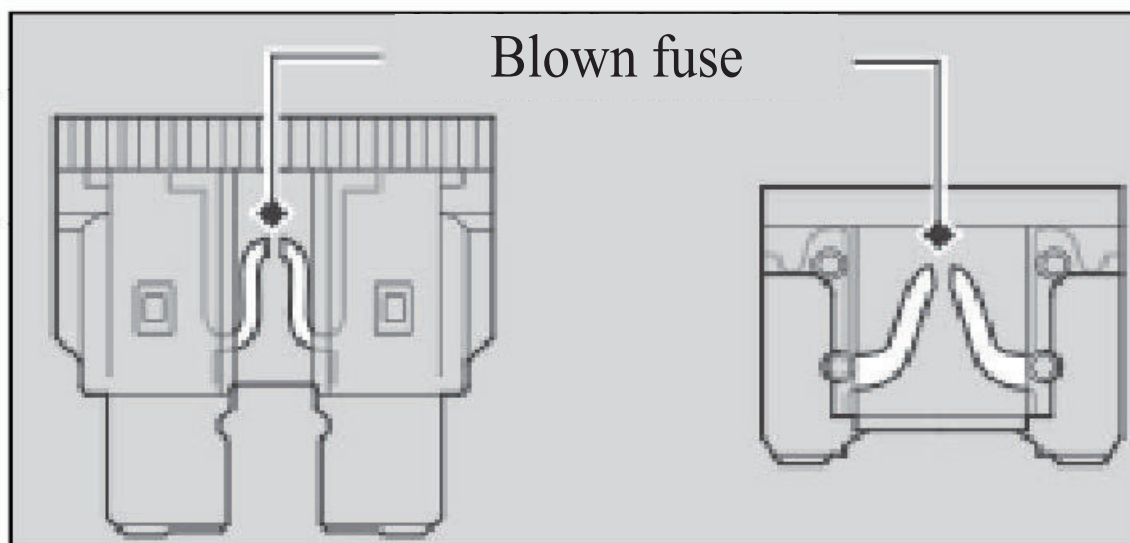

### Notes

- Fuses must be replaced with ones of the same rating. Using a fuse with a higher rating increases the risk of damaging the electrical system and may pose a fire hazard.
- Installing non-KEVOMOTO electrical accessories can overload the electrical system, lead to battery discharge, and even damage the system.

## Engine Oil

Engine oil consumption and degradation vary depending on riding conditions and usage duration. The higher the engine speed, the faster the oil consumption rate. When operating at high speeds or high RPM for extended periods, shorten the oil change interval. Regularly check the engine oil level and add the recommended engine oil if necessary.

When used in extreme temperatures, oil degrades more rapidly. Dirty or aged oil should be replaced promptly.

### ■ Choosing Engine Oil

The initial engine oil should be SN\_10W/40, and the maintenance engine oil should be API-classified SN grade or higher.

#### Notes

- Brake fluid can damage plastic and painted surfaces. If spilled, wipe it off immediately and clean thoroughly.
- Recommended brake fluid: DOT4 or equivalent.
- Use coolant specifically designed for non-aluminum engines, as ordinary tap water or mineral water can cause corrosion.

## Brake Fluid

Do not add or replace brake fluid except in an emergency. Only use brake fluid that has been freshly taken from a sealed container. If you have added brake fluid, please have the brake system inspected by an authorized KOVEMOTO Motorcycle service center as soon as possible.

## Coolant

Only use the original undiluted KOVE Motorcycle pre-mixed coolant, which offers superior protection against corrosion and overheating. Regularly check the coolant level and promptly add more if it falls below the minimum mark. The coolant has a freezing point of -40°C and a boiling point of 110°C.

## Drive Chain

The drive chain must be regularly inspected and lubricated. If frequently ridden on poor road surfaces, at high speeds, or with repeated rapid acceleration, the chain should be checked more often.

If the drive chain does not operate smoothly, produces unusual noises, has damaged rollers or loose pins, or missing or bent seals, have the chain inspected by an authorized KOVEMOTO Motorcycle service center.

Also inspect the drive sprocket and driven sprocket. If either shows wear or damaged teeth, have them replaced by an authorized KOVEMOTO Motorcycle service center.

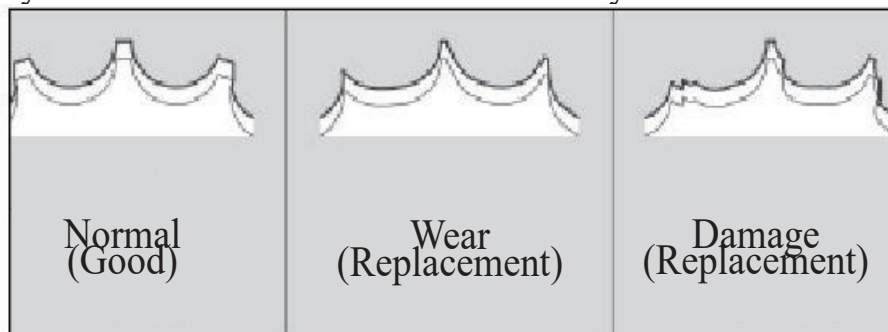

### Notes

- Using a new drive chain on worn sprockets will accelerate chain wear; both the drive chain and sprockets should be replaced simultaneously.
- Recommended lubricant: Specialized lubricant for chain oil seals.

## Cleaning and Lubricating

After checking the sag, clean the chain and sprockets while rotating the rear wheel using a dry cloth, a chain cleaner for sealed chains, or a neutral detergent. If the chain is dirty, use a soft brush. After cleaning, dry it and lubricate with the recommended chain oil.

Avoid using steam cleaners, high-pressure cleaners, wire brushes, volatile solvents like gasoline and benzene, scrubbing agents, chain cleaners, and lubricants that are not specifically designed for oil-sealed chains, as they may damage the chain oil seals.

Avoid getting lubricant on the brakes or tires, and refrain from using excessive lubricant to prevent it from splashing onto clothing or the motorcycle.

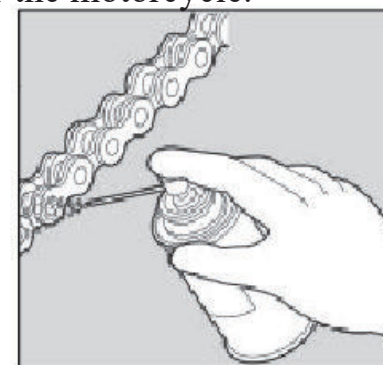

## Tire (Inspection/Replacement)

### Tire specifications

Front tire: 110/80 R19

Rear tire: 150/70 R17

### Abnormal wear check

Inspect the tire's contact surface for any signs of abnormal wear. Inspect the tread depth

Check the tread wear indicator marks; if the wear reaches the indicators, replace the tire immediately. Check the tire pressure  
When you feel the tire pressure is low, measure it with a pressure gauge. Check the tire pressure when the tires are cool, and do this at least once a month. Ensure the valve core cap is securely tightened; replace it with a new one if necessary.  
The standard tire pressure is: Front tire: 230 kPa; Rear tire: 250 kPa.

### Check the damage

Inspect the tires for cuts, cracks, exposed fabric, tire cords, nails, or other foreign matters embedded in the sidewall tread, and also check for any abnormal bulges or swelling on the tire sidewall.

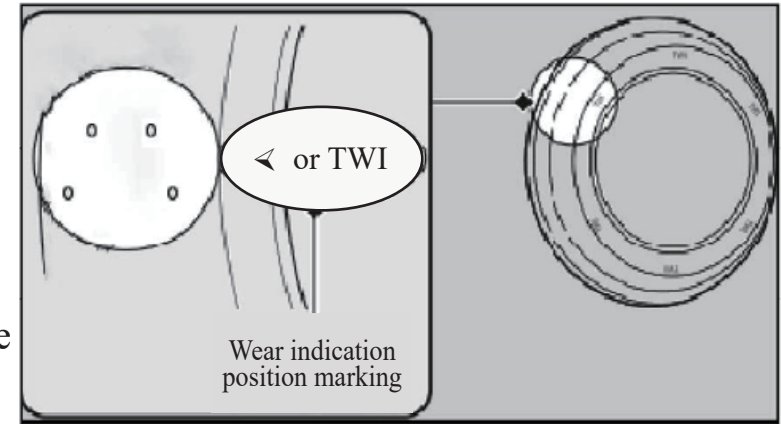

**Whenever replacing tires, follow these guidelines:**

- Use the recommended tires or equivalent products with the same size, structure, speed rating, and load capacity.
- After installing the tires, use the original KOVEMOTO motorcycle wheel balancer or equivalent equipment to balance and align the wheels.
- This motorcycle rim is designed for use with inner tubeless tires. Do not install Inner tube in tire yourself. If Inner tube is installed, it will rub against rim during rapid acceleration or braking, and the excessive heat will cause Inner tube to burst.

**▲ Warning**

- Using excessively worn or improperly inflated tires can lead to accidents, resulting in serious injuries or fatalities. Please follow the relevant tire inflation and maintenance guidelines provided in the Instruction Manual.
- Installing unsuitable tires can impair handling and stability, potentially causing accidents and even endangering lives.
- Always use the tire size and type recommended in this Instruction Manual.

## Air Filter

This motorcycle is equipped with a paper air filter element. Do not perform maintenance yourself. It should be cleaned or replaced by an authorized KOVEMOTO Motorcycle service center.

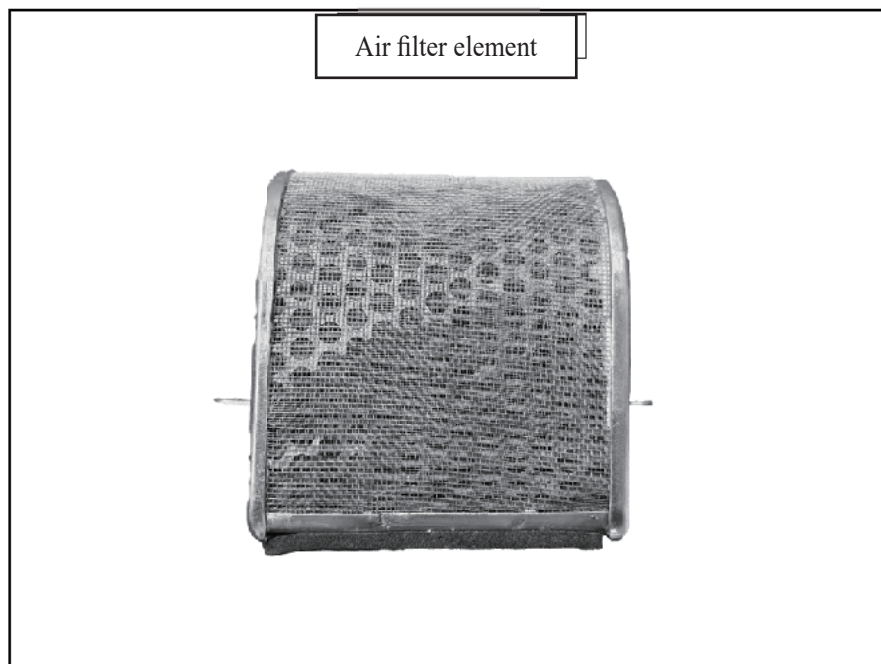

## Tools

The onboard tools are embedded under seat cushion towards the back.

You can use the onboard tools to conduct some simple repairs, fine-tune, and replacement of parts.

- Double-ended screwdriver
- CM5 pry tool
- Double-ended wrench 8\*10
- Double-ended wrench 12\*14
- Hexalobular internal wrench
- Toolkit

## Removal and Installation of Body Components

### Battery

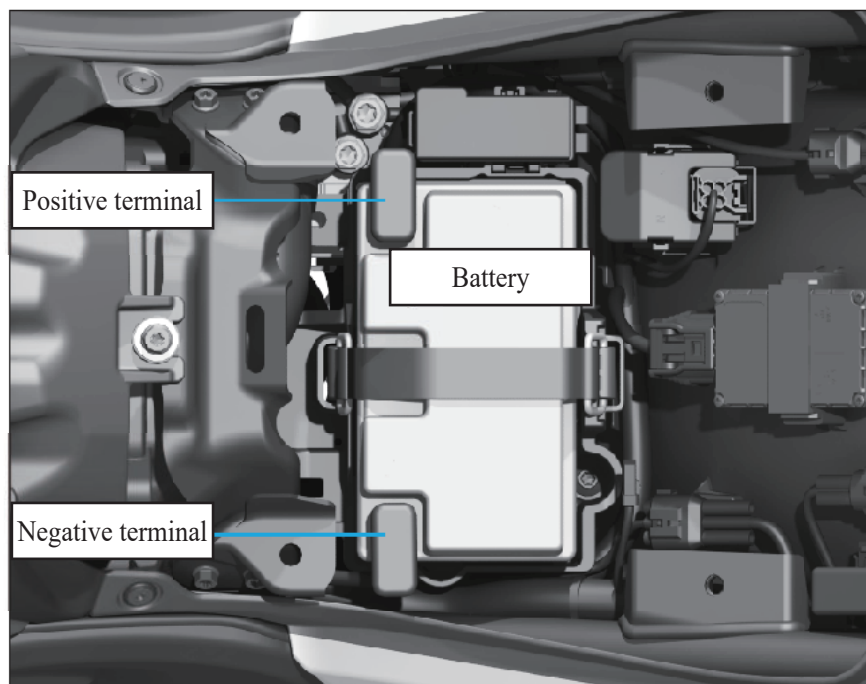

#### ■ Disassembly

Make sure the electronic lock is in the off state.

- 1.Remove the seat cushion.
- 2.Release the rubber strap from the back.
- 3.Disconnect the negative (-) terminal of the battery.
- 4.Disconnect the positive (+) terminal of the battery.
- 5.Remove the battery, being careful not to leave the bolts and nuts.

#### ■ Installation

Install all parts in the reverse order of removal, ensuring to connect the positive terminal (+) first and the negative terminal (-) last; ensure that the bolts and nuts are tightened.

## Seat Cushion

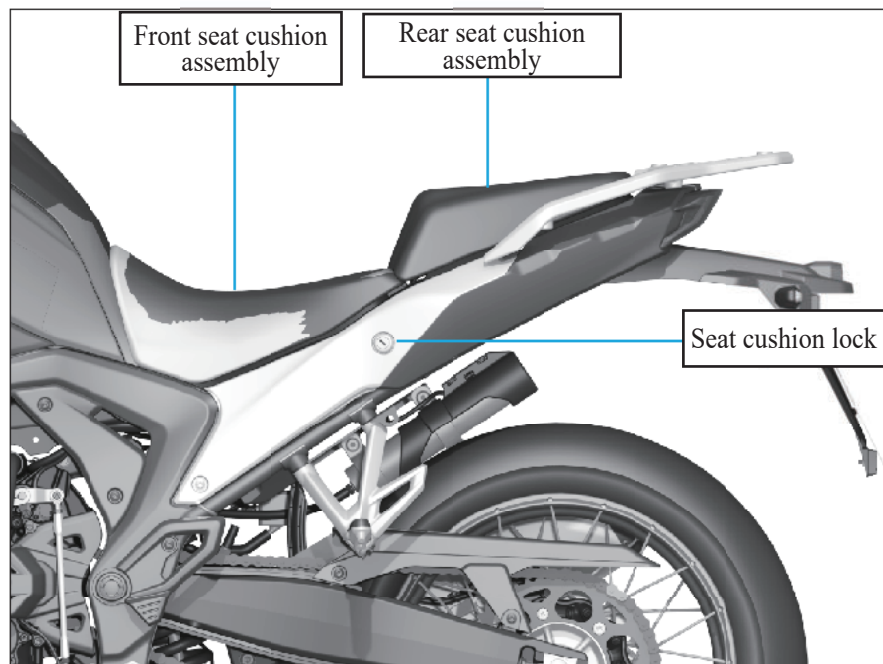

### Disassembly

1. Insert the mechanical key into the seat cushion lock, rotate the key clockwise, and at the same time, lift the rear end of the rear seat cushion assembly upwards to disengage it from the lock, and finally, apply slight force backwards to remove the rear seat cushion assembly.
2. Use the on-board tools to remove the bolts at the rear left and right positions of the front seat cushion assembly, then lift and disconnect the seat cushion heating harness connector.

### Installation

1. First, connect the seat cushion heating harness plug, align the rear end of the front seat cushion assembly with the rear mounting bores, and secure the screws.
2. Insert the front and rear pins of the rear seat cushion assembly into the frame slot respectively.
3. Align the seat lock pin with the lock hole, press the rear part of the seat downward, insert the lock pin into the lock hole of the seat lock and lock it automatically by the lock tongue, and pull it up slightly to ensure that the seat is firmly locked in place.
4. When the seat cushion is closed, the seat cushion will automatically lock.

### Notes

- Ensure the seat pin is securely inserted into the frame slot; otherwise, the seat may not support your weight and could be damaged.

## Three Cases (Optional)

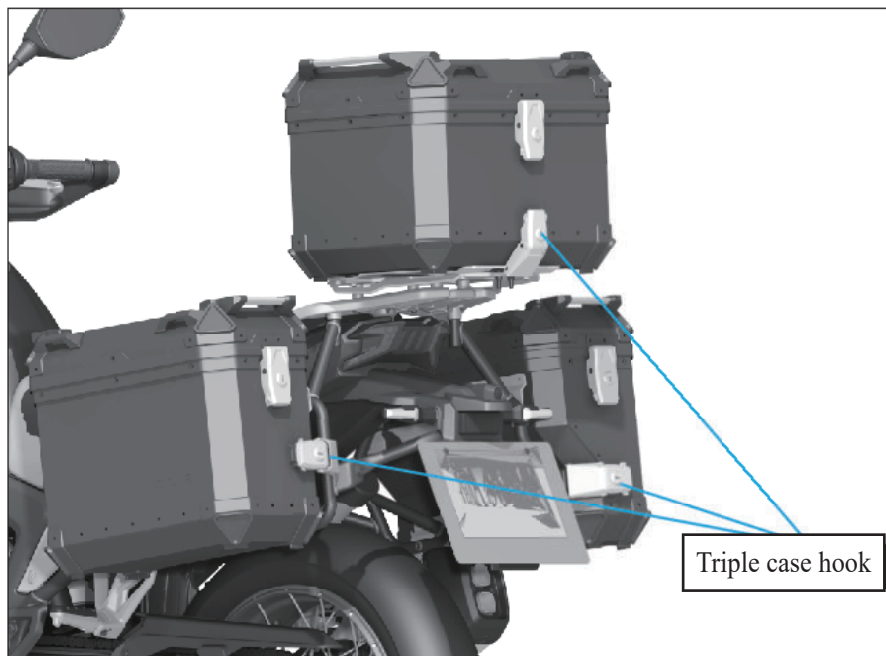

### Disassembly

1. Open the case hooks that connect the triple cases to the mounting bracket.
2. Lift the side case upward to disengage the four slots on the back of the side case from the mounting pegs on the side case bracket.
3. From front to rear, disengage the four slots at the bottom of the top case from the mounting hooks on the top case bracket.

### Installation

1. Align the four slots on the back of the side case with the mounting hooks on the side case bracket, then lower the side case from top to bottom so that the slots engage with the hooks.
2. Attach the hook to the side case mounting piece to secure the side case.
3. Align the slots at the bottom of the top case with the mounting hooks on the top case bracket, then slide the top case from rear to front so that the slots engage with the hooks.
4. Attach the hook to the top case mounting piece to secure the side case.

### Notes

- The maximum load capacity for each side case is 10 kg, and for the top case it is 5 kg.
- When riding with side cases, ensure proper left-right balance. Do not exceed a maximum speed of 120 km/h.

## Engine Oil

### Inspect and top up engine oil

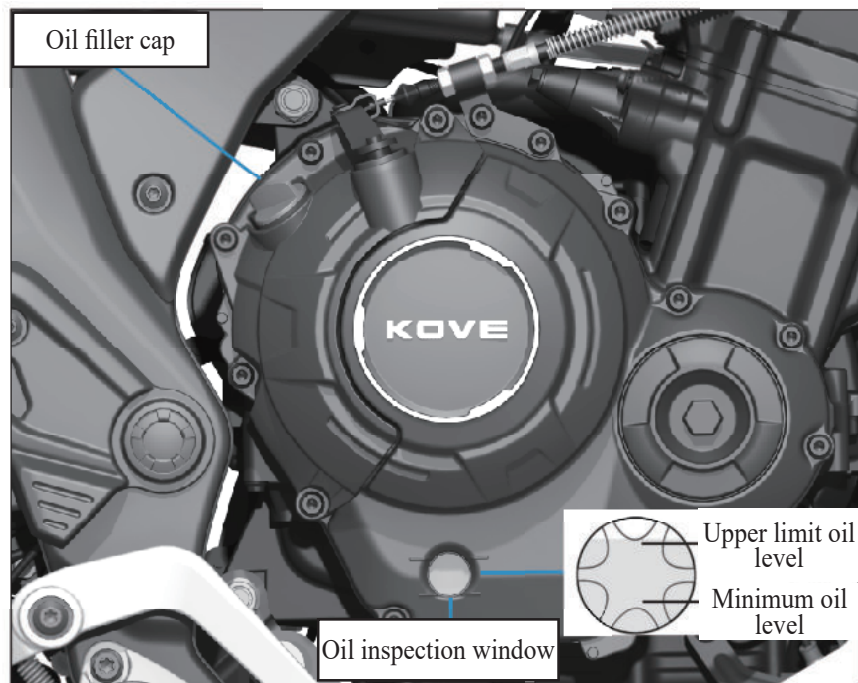

### Check the engine oil

1. Idle for 3-5 minutes, close the electronic lock to power off, then wait another 2-3 minutes.
2. Place the motorcycle vertically upward on a stable and flat ground, check whether the oil level is between the upper and lower limit mark from the engine oil inspection window.

### Add the engine oil

When the engine oil level is below or close to the lower limit mark, add the recommended engine oil.

1. Remove the engine oil filler cap, add the recommended oil to the upper mark of the oil level. Do not exceed the upper limit mark, and ensure that no foreign matters enter the engine oil filler. If there is any spillage, wipe it off immediately.
2. Reinstall and tighten the engine oil filler cap.

### Notes

- Long-term skin contact with oil shall be avoided. Wash thoroughly after contact with oil.
- Overfilling or underfilling the oil will damage the engine. Do not mix oils of different brands and grades, as this will affect lubrication and clutch operation.
- The used engine oil and container are harmful to health and the environment. They cannot be disposed of as household waste and should be handled in accordance with local environmental regulations.

## Replace the engine oil and the oil strainer

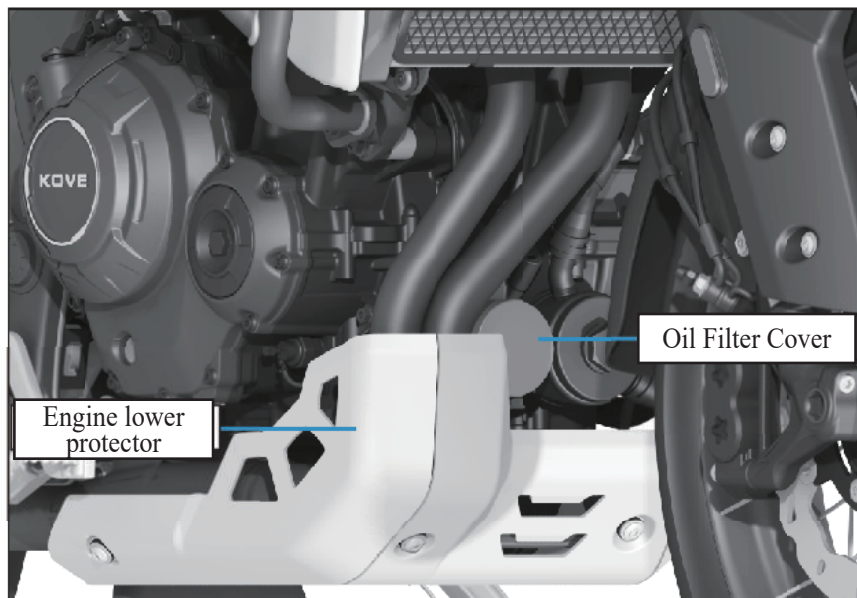

### Replace the engine oil and the oil filter

Special tools are required to replace the engine oil and the oil filter. We recommend that the inspection and maintenance be completed by an authorized KOVEMOTO Motorcycle service center. Please refer to the "Maintenance Interval Table" for the maintenance interval of engine oil and oil filter.

1.If the engine is cold, please idle for 3-5 minutes, close the electronic lock to power-off state, and then wait for another 2-3 minutes.

2.Park the motorcycle on a stable, level surface and place an oil drain pan beneath the drain bolt.

3.Remove the filler cap, oil drain bolt, and sealing washer, then drain the engine oil, ensuring the old gasket is not stuck to the engine.

4.Use filter wrench to remove the filter, drain the remaining engine oil, and ensure that the old rubber ring is not stuck to the engine.

5.Apply a thin layer of engine oil to the rubber seal on the new oil filter.

6.Install a new engine oil filter and tighten it (torque: 12 N·m).

7.Install a new sealing washer on the oil drain bolt and tighten the oil drain bolt (torque: 28 N·m).

8.Add the recommended original engine oil into the crankshaft tank, and tighten the oil filler cap after filling.

9.Check the engine oil for leakage.

**When replacing the engine oil filter, the required oil level: 3.2 L**

**When the engine oil filter is not replaced, the required oil level: 2.8 L**

**When reassembling after disassembling the engine, the required oil level: 3.4 L**

### Notes

- Using the wrong engine oil and oil filter strainer can seriously damage the engine.
- Dispose of the engine oil and oil filter strainer at the appropriate recycling center.
- Use the specified KOVEMOTO original engine oil and oil filter.

## Coolant

### Inspect the coolant level

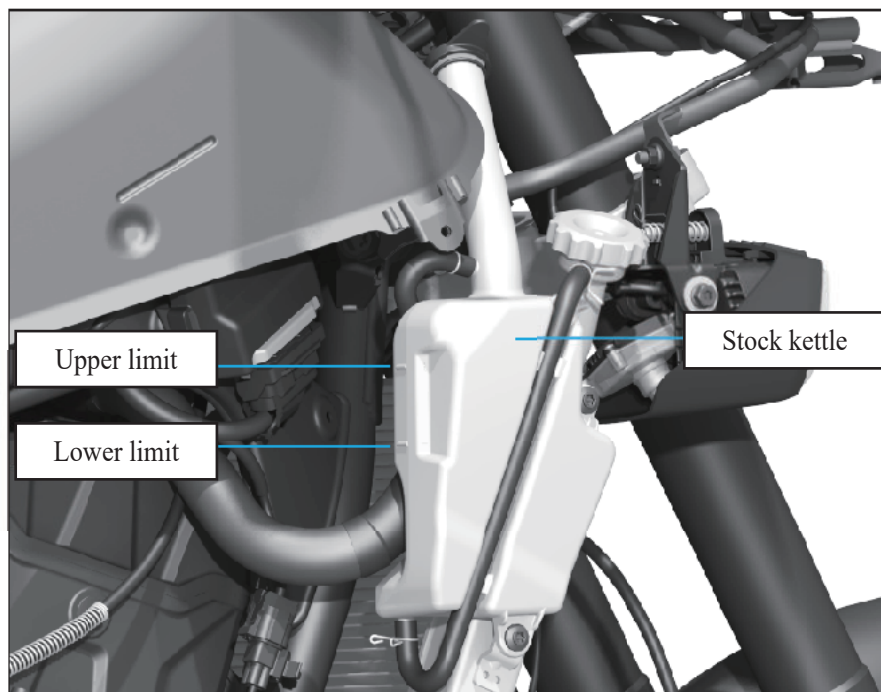

Check the coolant level in the reservoir when the engine is cool.

1. Park the motorcycle on a firm and flat level.
  2. Keep the motorcycle upright.
  3. Check if the coolant level in the water reservoir is between the upper limit and lower limit marks.
- If the coolant level drops significantly or the reservoir is empty, there may be a serious leak. Please have it inspected by an authorized KOVEMOTO Motorcycle service center.

### Add coolant

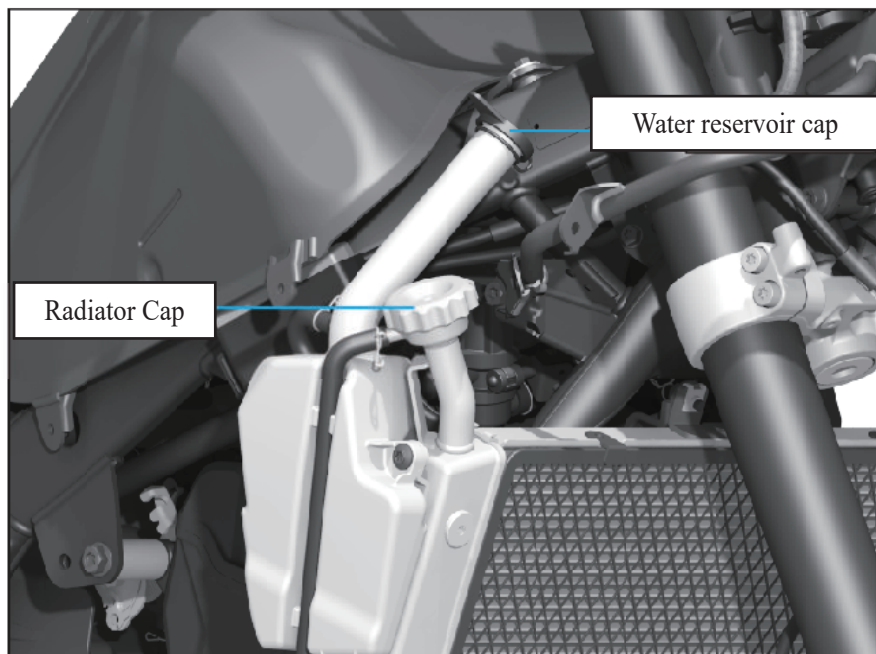

If the coolant is below lower limit, add the recommended coolant until the level reaches upper limit.

When adding the coolant, open the radiator cap to release pressure when the engine is cool, then open the water reservoir at the other end to add coolant. Ensure no foreign matter enter the cap opening and do not exceed upper limit during the process.

After completing the addition, reinstall the relevant caps.

### Replace the coolant

Unless you possess the appropriate tools and qualified mechanical skills, please entrust the coolant replacement to the authorized KOVEMOTO Motorcycle service center.

**Coolant capacity:**

**Radiator (including all water channels): 1.8L**

**Water reservoir (between upper limit and lower limit): 0.26 L**

#### **▲ Warning**

- Do not remove the radiator cap while the engine is still hot, as this may cause the coolant to spray out and potentially cause burns.

## Brake

### Inspect the brake fluid

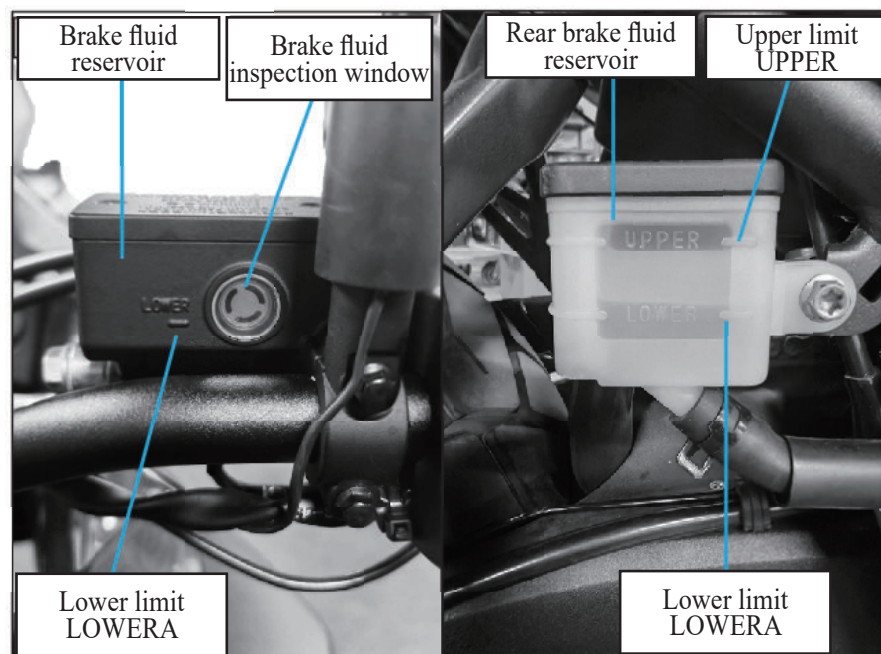

1. Place the motorcycle vertically on a firm and flat ground.
2. Check if the brake fluid reservoirs are horizontal.
3. Check if the brake fluid is visible in the inspection window. If the brake fluid level is below the lower limit of the inspection window, add it immediately.

If the brake fluid level in the oil cup is lower than the lower limit (LOWER) level mark or the free stroke of the brake rod and pedal is out of limit, users must check whether the brake pad is worn. If the brake pad is not worn, there may be leakage. Please have it repaired by an authorized KOVEMOTO Motorcycle service center.

### Check the brake pads

Inspect the condition of the brake pad wear indicator. If the brake pad wears down to the indicator mark, it must be replaced.

**Front** Inspect the brake pad from beneath the brake caliper.  
Brake pad lining thickness: 3.5mm (indicator mark indicates the wear limit)

**Rear** Inspect the brake pad from the right rear of the brake caliper.  
Brake pad lining thickness: 6.5mm (indicator mark indicates the wear limit)

If necessary, have the brake pads replaced by an authorized KOVEMOTO Motorcycle service center (when the wear limit is reached, both the left and right brake pads must be replaced simultaneously).

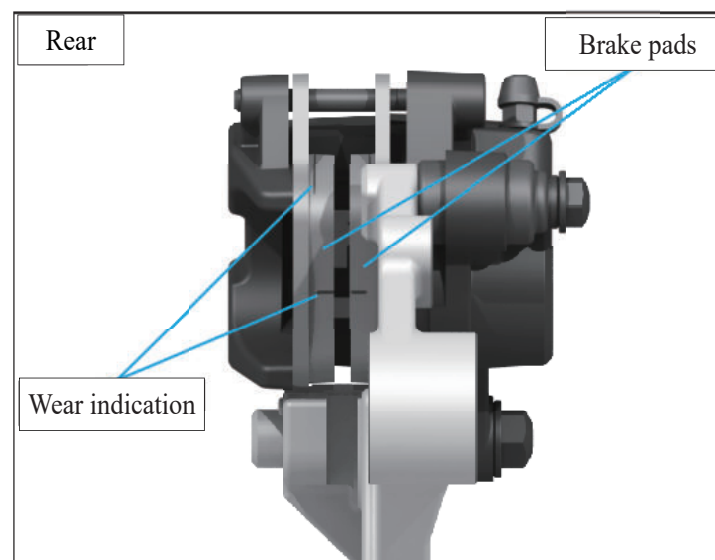
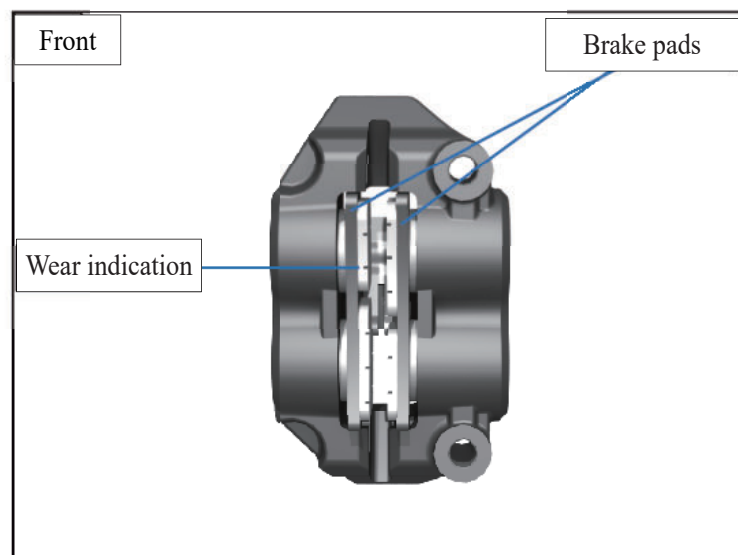

## Side Stand

### Check side stand

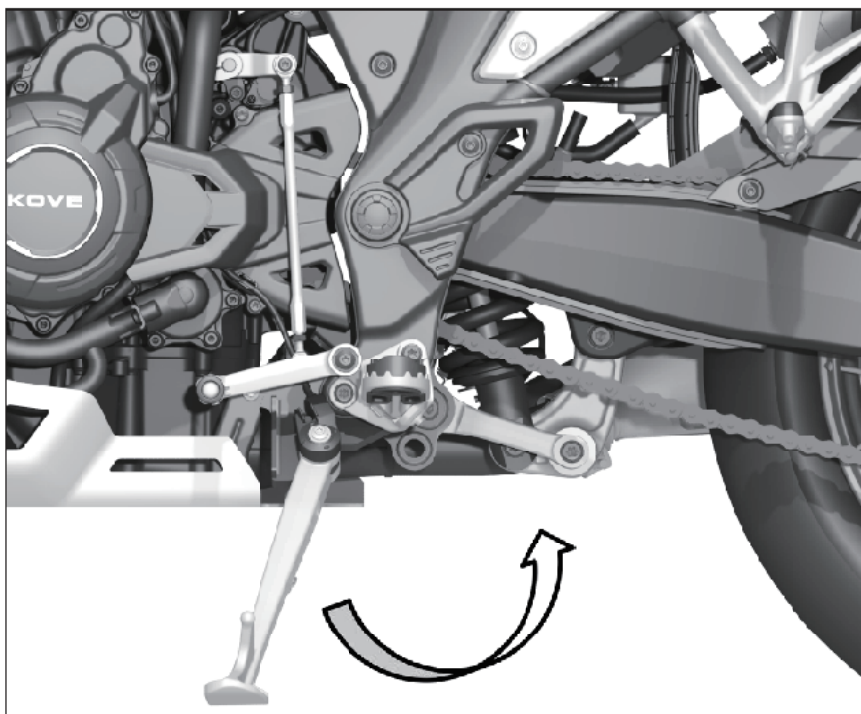

1. Check if the side stand operates smoothly. If the side stand is stuck or makes a squeaking noise, clean the pivot area and lubricate with clean grease.
2. Check the spring damages or inelasticity.

## Drive Chain

### Check the drive chain sag

Check the sag at various points along the chain. If the sag is inconsistent at any point, some links may be bent or kinked. Please have the chain inspected by an authorized KOVEMOTO motorcycle service center.

1. Put the transmission into neutral and turn off the engine.
2. Place the motorcycle vertically on a firm and flat ground.
3. Determine the chain sag by pushing the chain toward the swingarm in the area behind the chain guard.
4. Rotate the rear wheel forward and check if the chain operates smoothly.
5. Inspect the sprocket.
6. Clean and lubricate the drive chain.

Drive chain sag: 30-45 mm

If the sag exceeds 45mm, you must not continue riding the motorcycle.

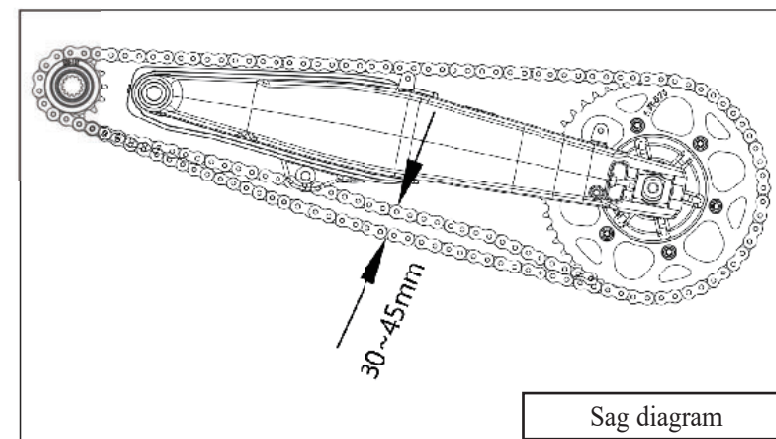

### Notes

- When inspecting the drive chain sag, ensure that the upper section of the chain is properly tensioned.

## Adjust the sag of the drive chain

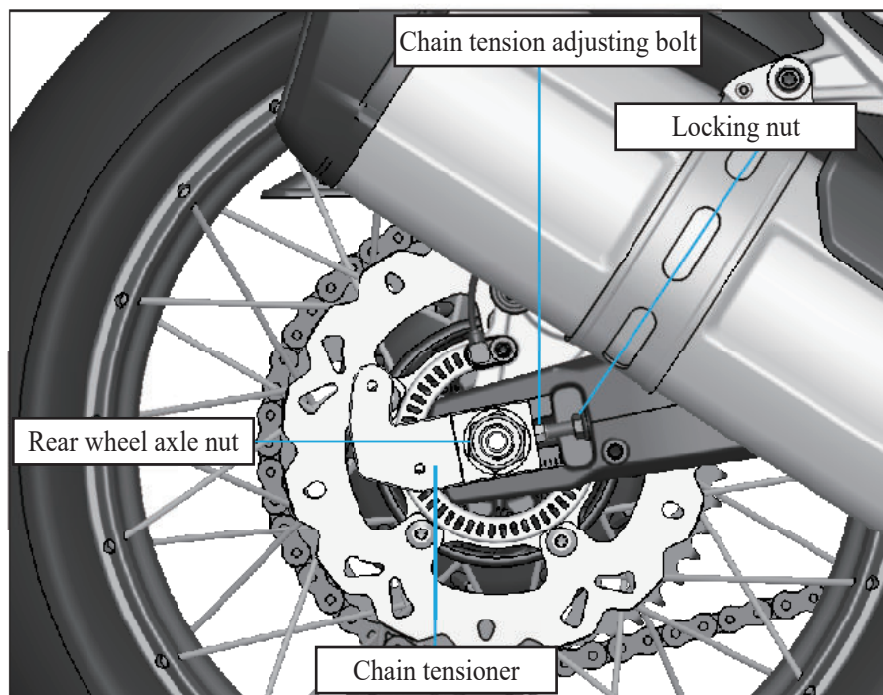

When adjusting the sag of the drive chain:

1. Put the transmission into neutral and turn off the engine.
2. Place the motorcycle vertically on a firm and flat ground.
3. Loosen the rear wheel axle nut.
4. Loosen the locking nut and chain tension adjusting bolt with an open-end wrench.
5. Rotate the chain tension adjusting bolt to adjust the chain tension. The chain tension adjustment range is 30-45mm (see sag diagram for details).
6. Push the chain in the direction of the swingarm at the middle of the lower part of the rear swingarm, to determine the reasonable sag of the chain.
7. The left and right chain adjuster should be adjusted to the same scale line.

### Notes

- When adjusting the drive chain sag, ensure that the upper section of the chain is taut.

## Clutch

Clutch lever free stroke: 10-20mm

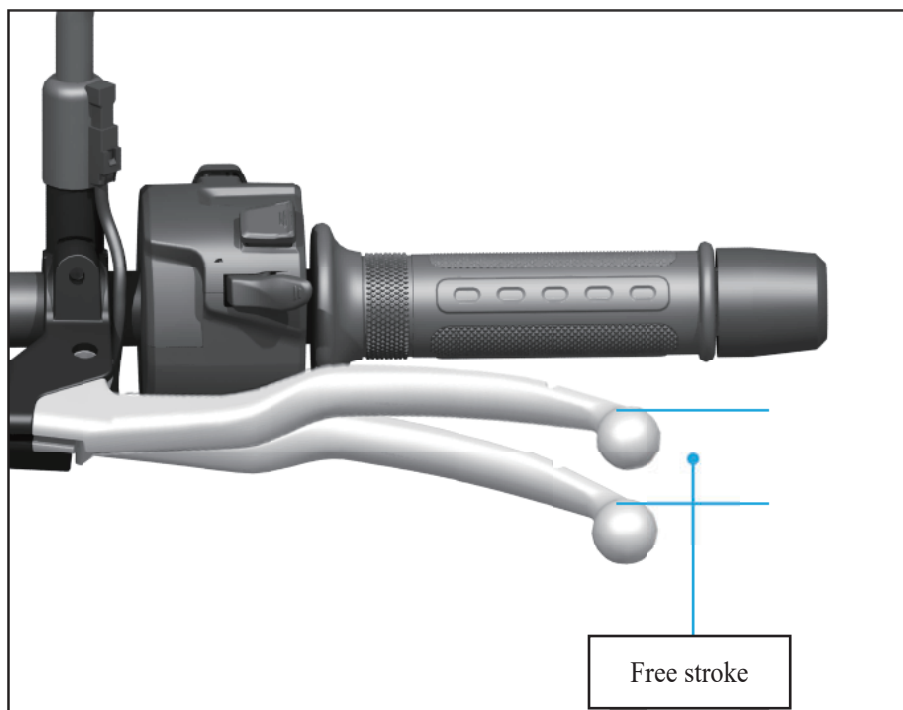

Inspect the clutch cable for any bends or signs of damage. If necessary, have it replaced by an authorized KOVEMOTO motorcycle service center.

Lubricate the clutch cable with a dedicated cable lubricant to prevent premature wear and corrosion.

### Notes

- Incorrect adjustment of the free stroke can lead to premature wear of the clutch.

## Accelerator

### Inspect the throttle

With the engine off, check if the throttle can smoothly transition from fully closed to fully open in all handlebar positions and if the free play is correct.

If the throttle operation is not smooth, it automatically closes, or the cable is damaged, have it inspected by an authorized KOVEMOTO motorcycle service center.

Free play of the throttle handle flange: 2-6mm

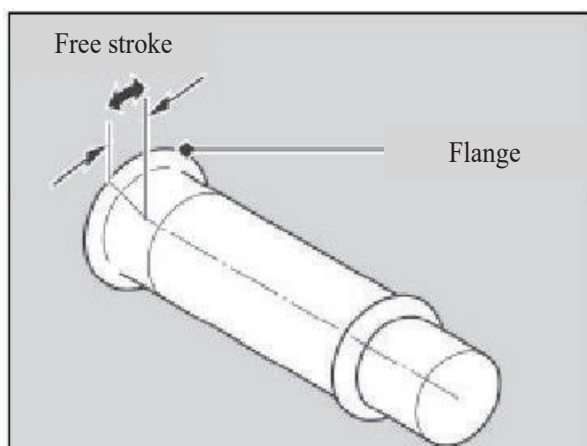

### Notes

- Do not turn the adjuster beyond its natural limit.

### Adjust the brake handle

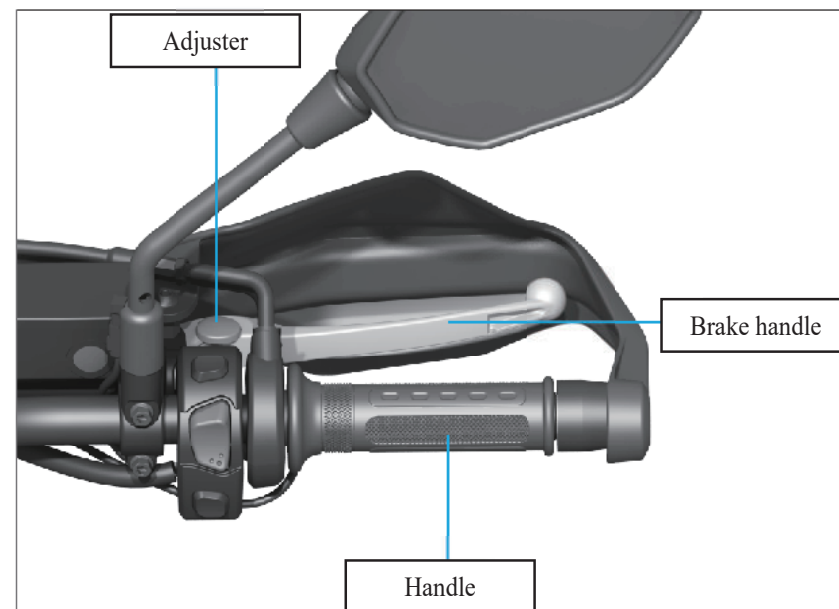

You can adjust the distance between the top of the brake handle and the handlebar grip.

### Adjustment method

Push the hand brake lever outward to the desired position while rotating the adjuster until the numbers align with the markings. After adjustment, check whether the brake handle works correctly before riding.

## Front Shock Absorber Adjustment

### Compression Damping Adjustment

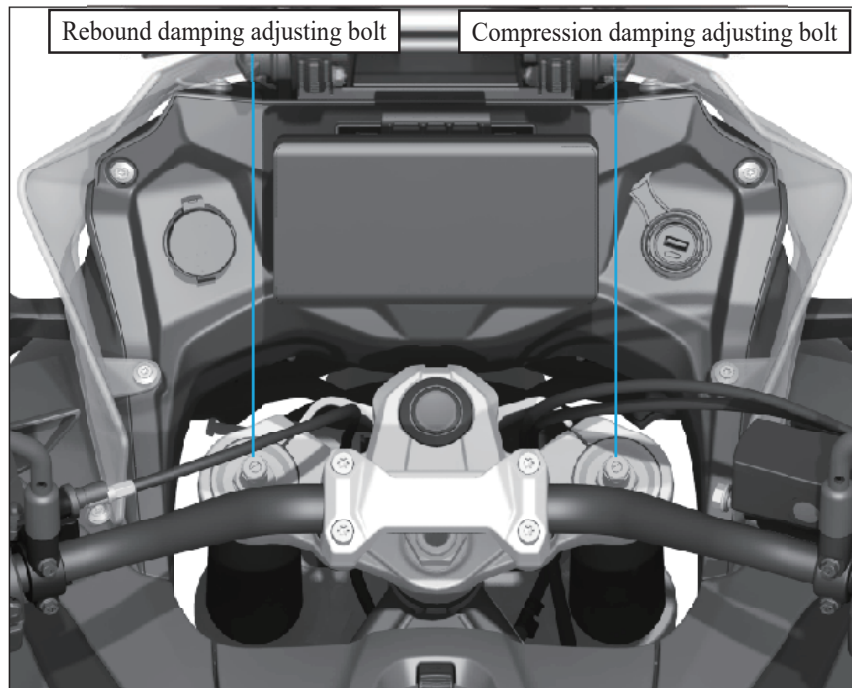

The adjustment of the compression damping affects the speed at which the front shock absorber compresses. The front shock absorber's compression damping is located on the right side of the shock absorber and is engraved with "COMP". Adjust the slotted part of the stud center.

The compression damping has  $22 \pm 2$  clicks. Rotating the adjusting bolt clockwise (H) increases compression damping, while rotating it counterclockwise (S) decreases compression damping.

#### **Set standard compression damping:**

1. Clockwise rotate the compression damping adjuster until it cannot be rotated.
2. Rotate the adjuster in a counterclockwise direction. The standard compression damping is set by rotating it 10 clicks counterclockwise from the fully tightened position ( where a click sound is heard).

#### Notes

- Do not apply excessive torque to the adjusting bolt, as it may damage the adjustment device. The adjusting torque shall not exceed  $0.5\text{N}\cdot\text{m}$ .

## Compression Damping Adjustment

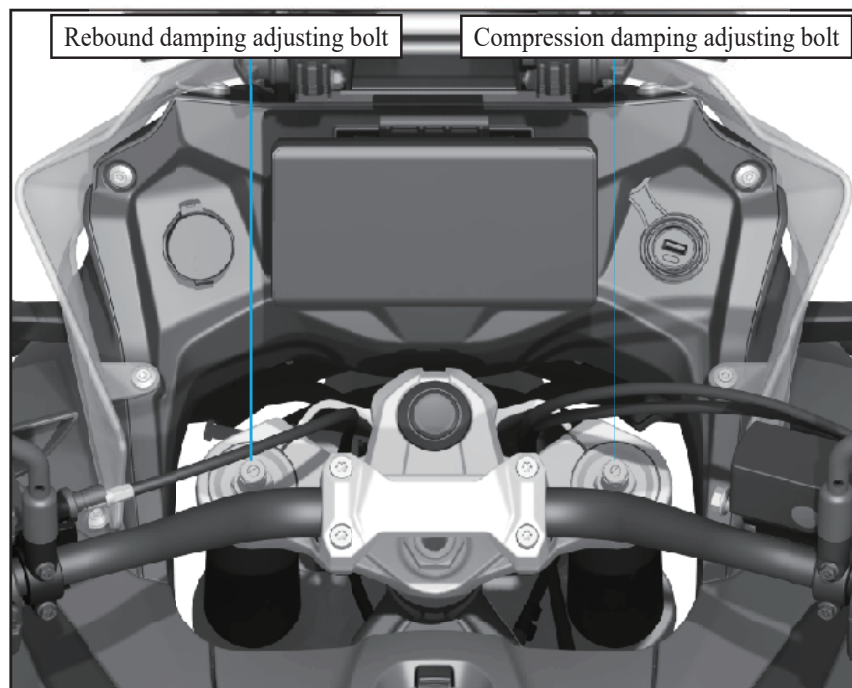

The adjustment of rebound damping will affect the rebound speed of the front shock absorber. The rebound damping of the front shock absorber is marked "TEN" on the left side of the front shock absorber. Adjust the slotted part of the stud center.

The front shock absorber has  $22 \pm 2$  rebound damping clicks. Rotating the adjustment bolt clockwise (H) increases rebound damping, while rotating it counterclockwise (S) decreases rebound damping.

### Set the standard rebound damping:

1. Clockwise rotate the spring-back rebound damping adjuster until it cannot be rotated.
2. Rotate the adjuster in a counterclockwise direction. The standard rebound damping is set by rotating it 7 clicks counterclockwise from the fully tightened position ( where a click sound is heard).

### Notes

- Do not apply excessive torque to the adjusting bolt, as it may damage the adjustment device. The adjusting torque shall not exceed  $0.5\text{N}\cdot\text{m}$ .
- By turning the adjuster clockwise, both compression damping and rebound damping can be

## Spring Pre-Compression Adjustment

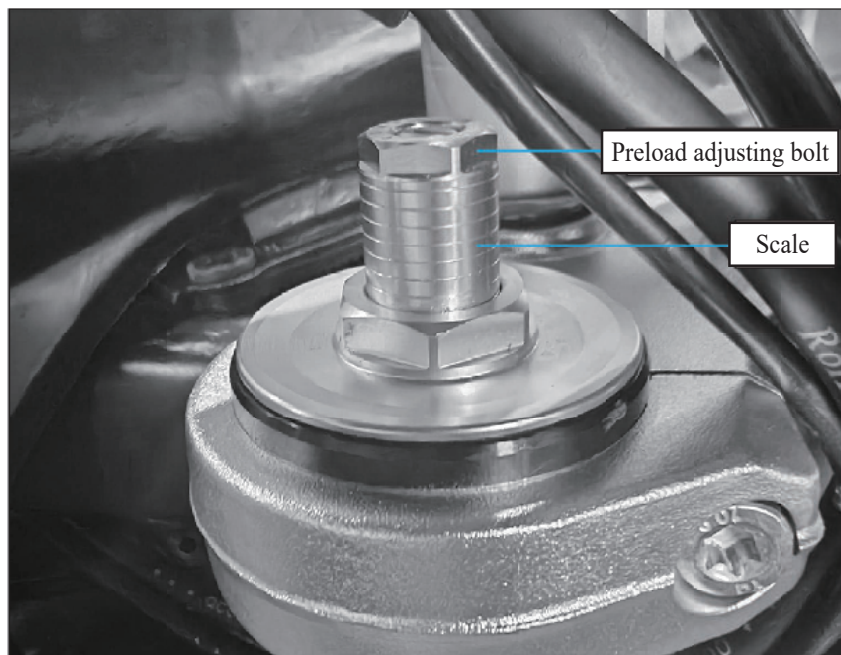

Spring pre-compression adjustment affects the force required to compress the spring. The higher the pre-compression, the greater the force required for the spring to compress the same distance; the lower the pre-compression, the less force the spring needs to compress the same distance. Adjust the hexagonal part of the front shock absorber stud.

Rotate the preload adjusting bolt clockwise to increase the spring preload, counterclockwise to decrease it.

Rotate the preload adjusting bolt clockwise to reduce the spring preload.

When adjusting the spring pre-compression, ensure the scale marks on both the left and right sides of the shock absorber are equal, with one mark representing 2mm.

You can make adjustments based on your weight and riding conditions. Ensure that after each adjustment, the bolts on left and right shock absorbers are set to the same position.

## Rear Shock Absorber Adjustment

The rear shock absorber assembly includes a shock airbag containing high pressure nitrogen. Do not attempt to remove, repair or dispose of the device. Piercing or exposure to flame may also cause an explosion, causing serious injury. Repair or disposal should be completed by special repair shop of KOVEMOTO.

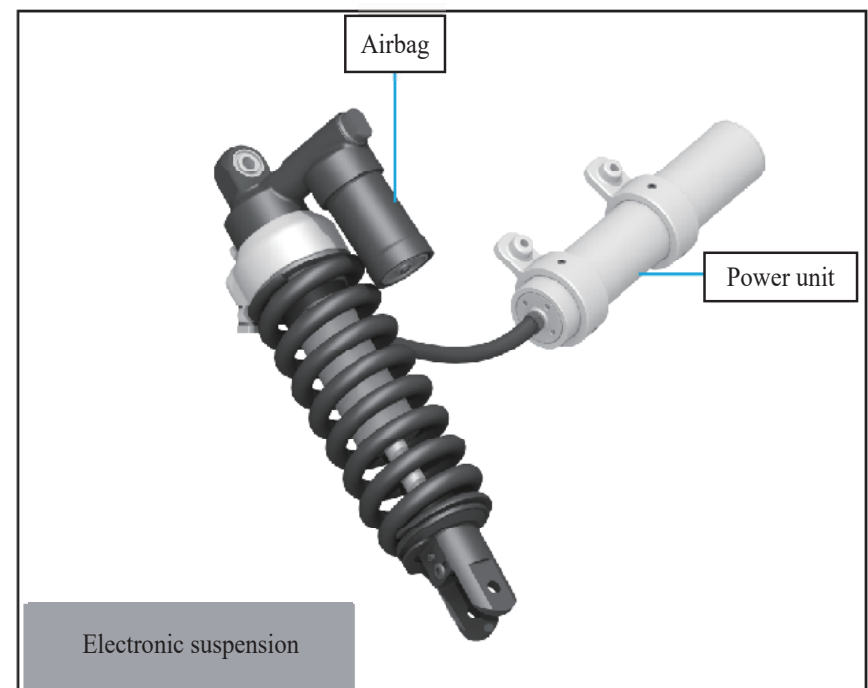
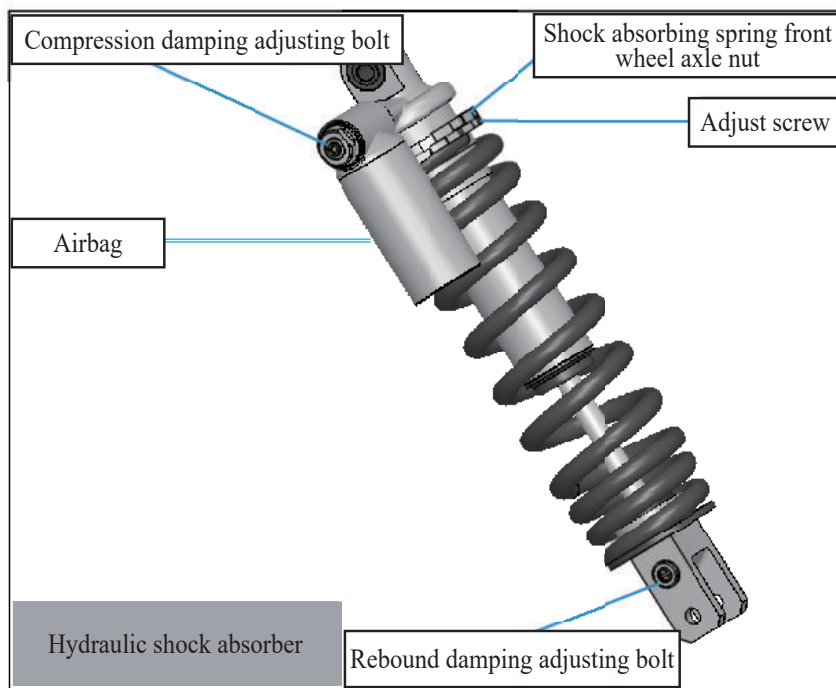

### Notes

- The high-configuration electronic suspension system features electronic preloading, allowing for quick adjustment of preload status and resistance mode via the instrument control interface, eliminating the need for manual adjustment.

## Spring Preload Adjustment

Adjust the spring preload after the engine has been stationary for some time. Loosen the shock absorber spring locking nut, then rotate the shock absorber spring preload adjusting nut to adjust the spring preload.

Rotate the knob clockwise to increase the spring preload and reduce the spring length.

Rotate the knob counterclockwise to reduce the spring preload and increase the spring length. The preloaded spring (standard) length is  $251.5 \pm 1.5$  mm.

After the adjustment is completed, hold the adjusting nut and tighten the shock absorber spring lock nut (torque:  $35 \pm 3$  N·m).

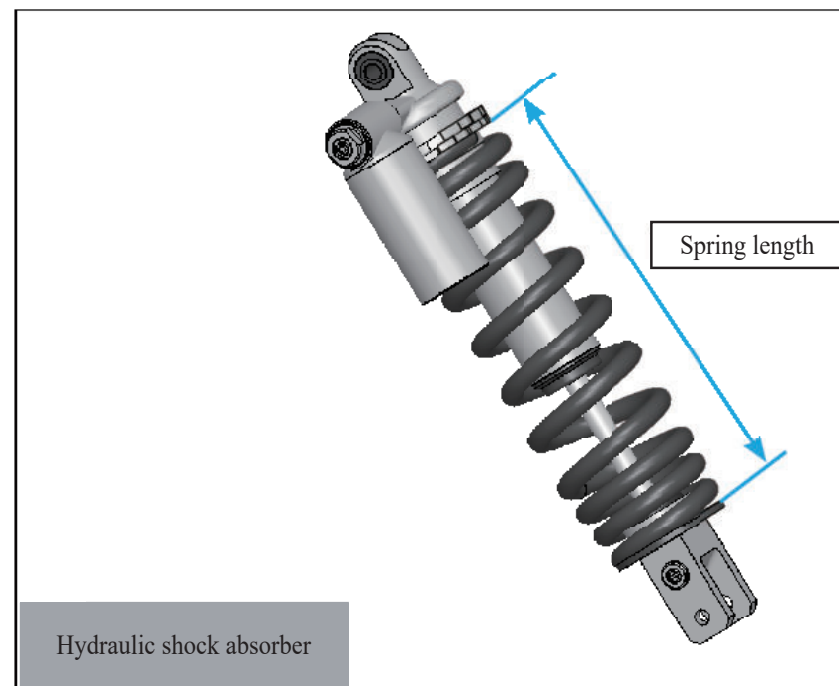

### Compression Damping Adjustment

The compression damping adjuster is located at the upper left of the rear shock absorber, with 20 clicks of compression damping. The compression damping increases after clockwise (H) adjustment, and the compression damping decreases after counterclockwise (S) adjustment.

#### Set standard compression damping:

1. Rotate the adjuster clockwise (H) until it cannot be rotated.
2. Rotate the adjuster counterclockwise for 10 clicks from the hardest position.

### Rebound Damping Adjustment

The spring-back rebound damping adjuster is located at the lower left end of the rear shock absorber, with 20 clicks of rebound damping. Rotating the adjusting bolt clockwise (H) increases rebound damping; rotating it counterclockwise (S) reduces rebound damping.

#### Set the standard rebound damping:

1. Rotate the rebound damping adjusting bolt clockwise (H) until it cannot be rotated.  
Rotate the adjuster in a counterclockwise (S) direction. The standard rebound damping is to rotate 8 clicks counterclockwise from the hardest position (where a click sound is heard).

### Notes

- Gently rotate the adjusting bolt to prevent damage to the shock absorber.
- When adjusting compression damping or rebound damping, always use a properly sized tool to avoid damaging the device.
- Make sure that the adjusting bolt is firmly in the fixed position during each adjustment.
- The adjusting torque for compression damping and rebound damping shall not exceed 0.5 N·m.

## Shock Absorber Inspection

**Check and clean all parts of the shock absorber regularly to ensure optimum performance:**

1. Check that the front shock absorber dust seal are clean and that there is no soil or dirt on the front shock absorber.
2. Check for oil stains under the spring strut dust seal. If there are signs of oil leakage, replace the damaged dust seal and oil seal.
3. Pinch the hand brake lever and press the handlebar back and forth several times to check whether the front shock absorber rebounds smoothly.
4. Press the seat cushion several times to check whether the rear shock absorber works smoothly.

## Headlight

### Adjust the headlight beam

You can adjust the angle of the headlight beam by rotating the adjusting screw, and the clockwise rotation is the overall rise of the headlight beam; The counterclockwise rotation is the overall decline of the headlight beam. Please comply with local laws and regulations.

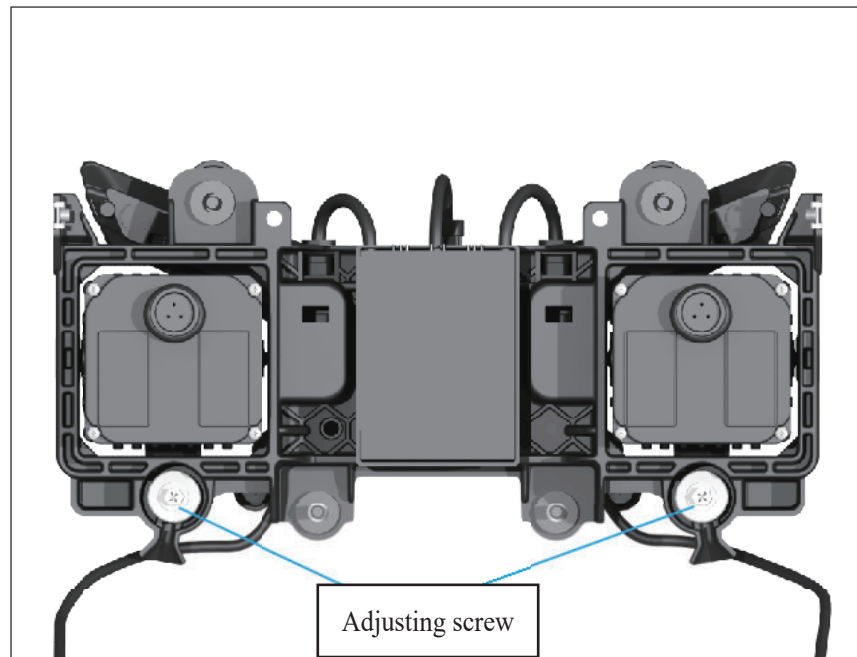

# Fault Handling

The Engine Fails To Start .....	71
The Warning Indicator is On or Flashing .....	72
Puncture .....	74
Removing The Wheel .....	75
Electrical Malfunction .....	78

## The Engine Fails To Start

### Engine no-start (starter motor operates)

#### Inspect the following items:

- Verify that the correct engine start sequence is being conducted.
- Check if there is fuel in the tank.
- Check whether the battery voltage is too low.
- Check if side stand retracted.

### Starter motor failure

#### Inspect the following items:

- Verify that the engine start sequence is correct.
- Ensure that the engine OFF switch is in the operating position.
- Check whether the battery voltage is too low, the fuse is blown, or the battery connection is loose. If the problem persists, please have it inspected by an authorized KOVEMOTO motorcycle service center.

## The Warning Indicator is On or Flashing

### Oil pressure indicator

If the oil pressure indicator is on, push the motorcycle to a safe side of the road and turn off the engine, and take the following measures:

1. Check the engine oil level and add oil if necessary.
2. You can continue to ride only after the indicator goes out.
3. When the oil is at or near the lower limit, a rapid increase in speed may cause the indicator light to illuminate.
4. If the oil level is at a normal level and the indicator is still on, please turn off the engine and contact the special repair shop of KOVEMOTO.
5. If the engine oil drops quickly, your motorcycle may leak oil or have other serious problems, please send it to the special repair shop of KOVEMOTO.

### Electronic injection malfunction indicator light

If the EFI fault indicator comes on while riding, there may be a serious problem with your electronic fuel injection system. Please slow down and have it inspected by a KOVE authorized service center as soon as possible.

### Turn indicator light

If the turn signal flashes abnormally or at an increased frequency during use, promptly check for any faults to prevent incorrect signals from causing safety hazards. Besides, have it inspected and repaired at an authorized KOVE motorcycle service center as soon as possible.

### Notes

- Continued driving at low oil pressure can seriously damage the engine.

### ABS fault indicator (Anti-lock braking system)

If the ABS fault indicator shows any of the following conditions, it indicates a fault in your ABS, and emergency braking will not provide anti-lock function. Please have it inspected by a KOVE authorized service center as soon as possible.

- During riding, the ABS fault indicator stays on or flashes .
- When the electronic lock is powered on, the indicator does not illuminate.
- When the speed is above 5 km/h, the indicator does not extinguish.

The ABS fault indicator may flash or stay on under the following conditions:

- Rotating the front wheel alone.
- Rotating the rear wheel alone.
- The rear wheel gets slippery.
- Riding on special road surfaces.

The electronic lock can be closed to the power-off state, then briefly press the electronic lock button to power on and reset the system.

### Water temperature indicator

If the water temperature indicator is on during the ride, push the motorcycle to a safe side of the road and turn off the engine, and take the following measures:

- 1.Wait for cooling down: Do not open the water tank cap immediately (hot coolant can spray out and cause injury). Let the engine sit for at least 30 minutes until the coolant temperature drops to normal.
- 2.Check coolant level: After cooling down, open the water tank cap and check the coolant level. Add coolant if necessary.
- 3.Check for leakages and malfunctions: Inspect the water pipes and water tank for any leakages, and ensure the fans are running properly. If you detect any leakages or fan issues, do not continue riding. Take your motorcycle to an KOVEMOTO authorized repair shop for maintenance.
- 4.Short-distance emergency (only when necessary): If the warning indicator extinguishes after replenishing the coolant and there is no leakage, you may drive at low speed for a short distance to the repair shop. Continuously monitor the temperature gauge during the trip and stop immediately if the warning indicator comes on again.

#### Notes

- Continuing to ride with an overheated engine can cause serious engine damage.
- Running the engine at high speed in neutral for an extended period may trigger a high coolant temperature alarm.

## Puncture

Repairing a flat tire or removing a wheel requires special tools and professional skills. We recommend leaving such maintenance tasks to a KEVO authorized repair shop. If you have performed overtightened tire repair, be sure to have tire inspected or tire replace KOVE authorized service center.

### **Perform emergency repairs using a tire repair kit.**

If your tire has a minor puncture, you can use an inner tubeless tire repair kit to perform emergency repairs.

Follow the instructions provided by the tire emergency repair kit. Riding a motorcycle with a temporarily repaired tire is very dangerous, and the speed should not exceed 50 kilometers per hour. Please have the tire replaced as soon as possible at an KEVO motorcycle repair shop.

### **▲ Warning**

- Riding a motorcycle with a temporarily patched tire is extremely hazardous. If the patch fails, it could lead to an accident, causing severe injuries or fatalities.
- If you must ride a motorcycle with a temporarily repaired tire, ride cautiously and slowly, not exceeding 50 km/h, until the tire is replaced.

## Removing The Wheel

### Front wheel

If you need to remove the wheel to repair a punctured tire, follow the steps below. Be careful not to damage the wheel speed sensor and ABS ring gear when removing and installing the wheel.

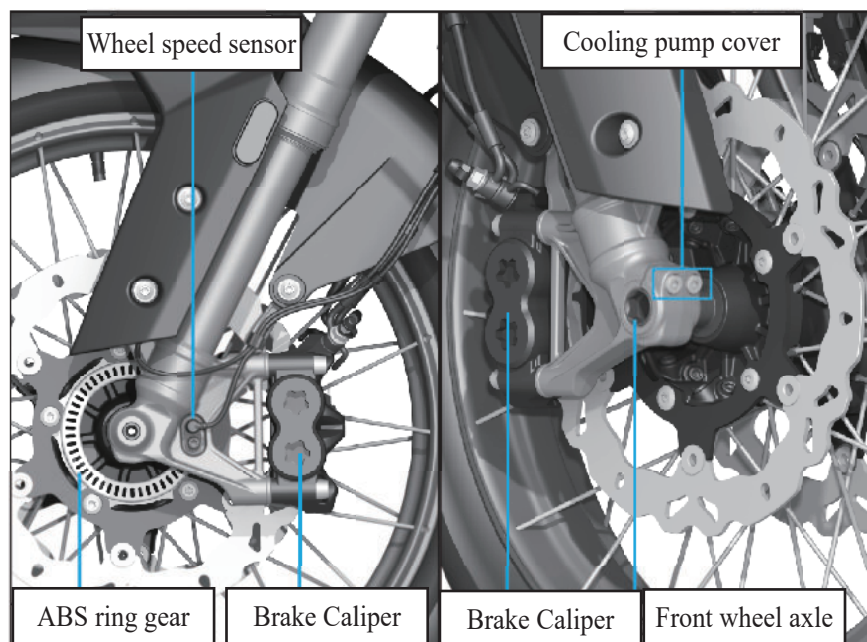

### Disassemble:

1. Securely support your motorcycle with a maintenance bracket or a crane and lift the front wheels off the ground.
2. Remove the front fender.
3. Remove the left and right brake calipers.
  - Support the brake caliper assembly well and do not hang it on the brake hose. Do not twist the brake hose.
  - Avoid getting lubricating oil, engine oil or dirt on the brake disc or brake pad.
  - When the brake caliper is removed, do not pull the brake handle.
  - Be careful to prevent the brake caliper from scratching the wheel during removal.
4. Loosen the wheel shaft locking bolt and front wheel axle.
5. Remove the front wheel axle and front wheel.

## Installation

1. Clean the front axle and the locking bores of the front shock absorber. Apply grease evenly around the groove between the main and auxiliary lips of the front hub oil seal.
  2. Place the front wheel between the front shock absorber, insert bushing (left) into the left mounting bore of the front wheel.
  3. Insert the front wheel axle through the front wheel from right to left and tighten it (front wheel axle M16, torque  $70 \pm 2 \text{ N}\cdot\text{m}$ ).
  4. Place the front wheel on the ground, then shake the front fork up and down a few times to ensure it returns to the correct position.
  5. Install the brake caliper, squeeze the hand brake lever, and tighten the bolts (torque:  $45 \text{ N}\cdot\text{m}$ ). Prevent the brake caliper from scratching the wheel during installation. Please use a new assembly bolt when installing the brake caliper.
  6. Install the two right-side locking bolts (front wheel axle locking bolt M8, torque:  $22 \text{ N}\cdot\text{m}$ ) and the front fender.
  7. Lift the front wheel off the ground, and after releasing the brake lever, check if the wheel turns smoothly.
- If a torque wrench was not used during the installation process, please take it to an authorized KOVEMOTO motorcycle service center as soon as possible. Improper installation may result in reduced braking performance.

## Notes

- When reinstalling the wheel or caliper, carefully position the brake disc between the brake pads to prevent scratching them.
- When installing the front wheel, first tighten the front axle, then secure the lock bolt on the right side of the front axle. The order of these steps cannot be reversed.

## Rear wheel

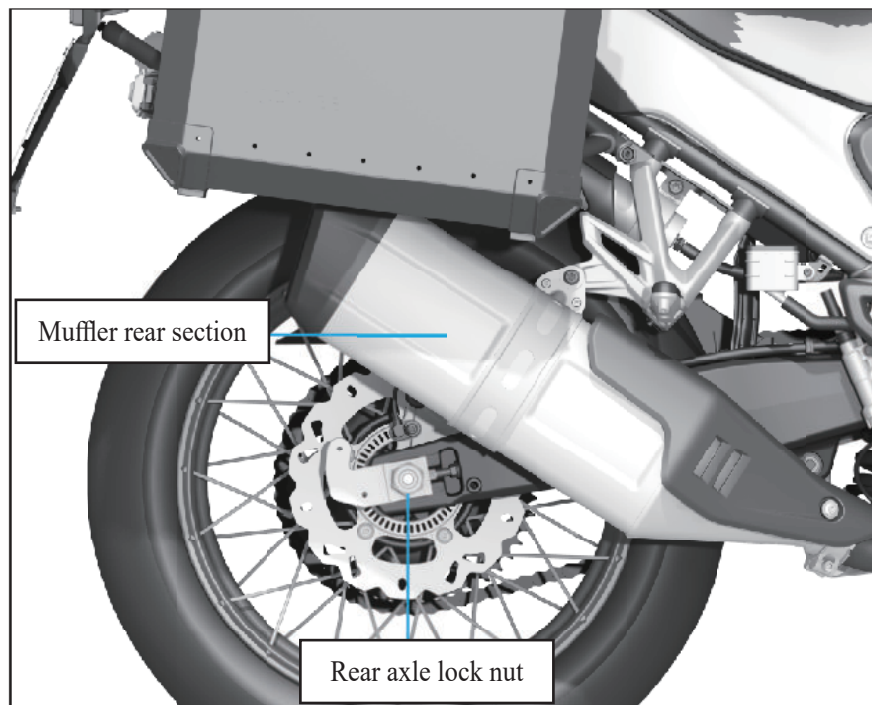

### Disassembly

1. Park the motorcycle on a firm and flat level.
2. Firmly support your motorcycle with side brackets or service bracke and lift the rear wheels off the ground.
3. Remove the rear section of the muffler assembly and chain guard.
4. Remove the rear wheel axle nut, rear wheel axle, and rear wheel bushing.

5. Remove the rear wheel.

### Installation

1. Install the rear wheel in the reverse order of removal to prevent the brake caliper from scratching the wheel during installation.
2. Align the rear wheel bore with the rear swingarm bore. First, install the rear wheel bushing (the bushing should be lubricated with grease), then insert the rear wheel axle from left to right into the wheel assembly bore.
3. Reinstall the drive chain onto the drive sprocket and adjust the drive chain sag.
4. Tighten the rear wheel axle nut (Torque: 128 N·m).
5. Install the chain guard and the rear section of the muffler.
6. Check the wheels; they should be rotating freely.

If a torque wrench was not used during the installation process, please take it to an authorized KOVEMOTO motorcycle service center as soon as possible. Improper installation may result in reduced braking performance.

### Notes

- When reinstalling the wheel or caliper, carefully position the brake disc between the brake pads to avoid scratches.

## Electrical Malfunction

### Fuse Blown

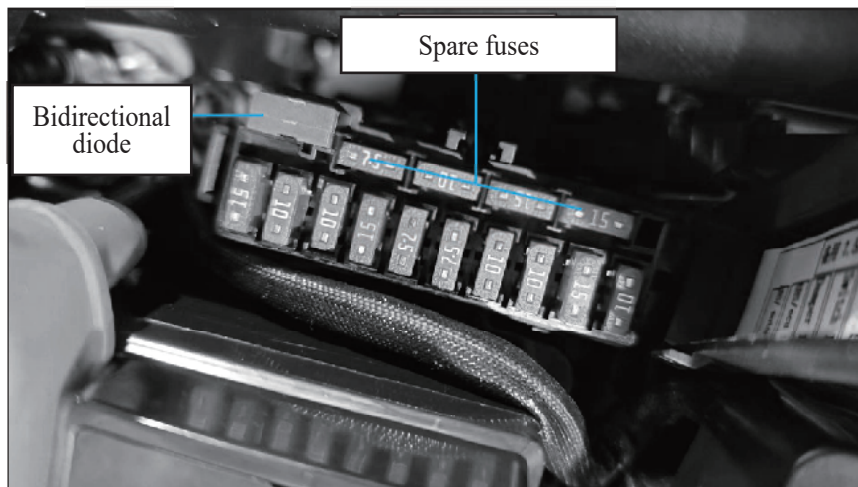

### Replace the fuse wire.

1. Remove the seat cushion.
2. Open the fuse box, remove the fuse, and check if the fuse is blown. If blown, be sure to replace it with the fuse with the same specification.
3. Close the fuse box cover and install the seat cushion.

### Notes

- Before handling the fuse, please refer to "Inspect and replace the fuses".
- The bidirectional diode is not a fuse; it is part of the starting control circuit. Damage to this component will result in a no-start condition.

## Battery Dead

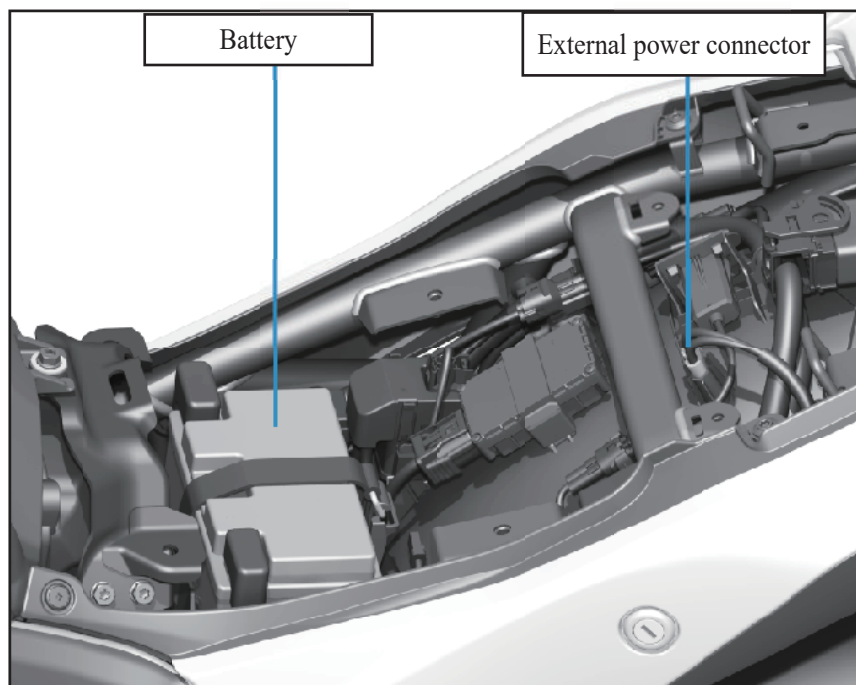

### Battery Charging

Please charge the battery using a dedicated motorcycle lead-acid battery charger. Remove the battery from the motorcycle before charging. If the battery does not recover after charging, please contact the authorized KOVEMOTO Motorcycle service center.

### Emergency Jump Start

When the vehicle battery is discharged, the engine can be quickly started by connecting a 12 V motorcycle-specific jump starter to the external power connector located under the seat cushion, avoiding the inconvenience of waiting for roadside assistance or replacing the battery.

After starting the vehicle using the emergency jump-start function and riding for approximately 30 minutes, if the engine still cannot be restarted after being turned off, please contact an authorized KOVE motorcycle service center.

### Notes

- Avoid using a car battery charger or a motorcycle lithium battery charger for charging, as this may result in battery damage or even a fire.
- The emergency jump start should only be used in urgent situations. Remove the jump starter immediately after starting the engine.

# Relevant Information

Key.....	81
Storage Box .....	82
Instruments and Millimeter-Wave Radar.....	83
Motorcycle Care .....	84
Motorcycle Parking .....	87
Motorcycle Transport .....	88
You and Your Environment .....	88
Vehicle Identification Number, Engine Number, and Nameplate.....	89
Catalytic Converter.....	90

## Key

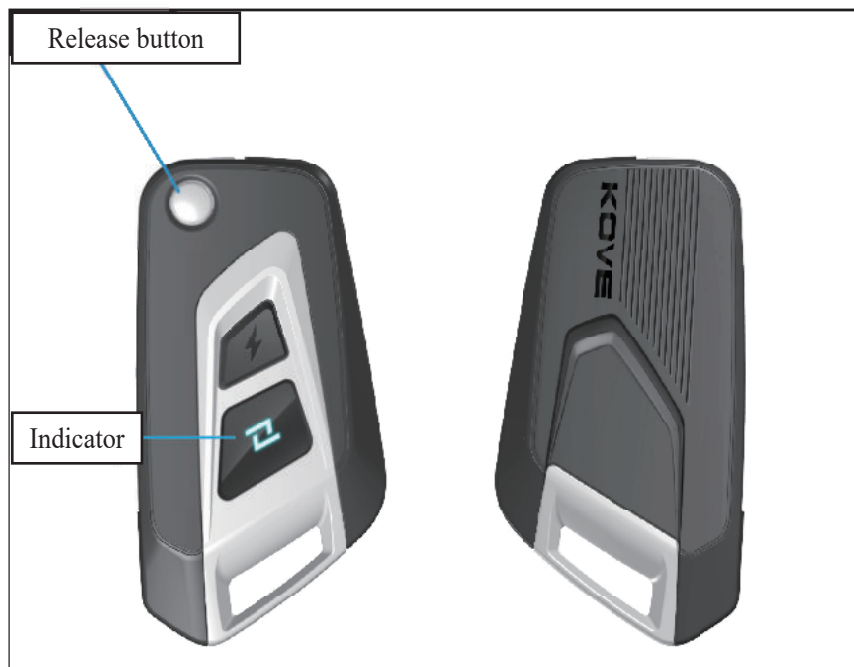

This motorcycle is equipped with an electronic remote key. Press the release button at the bottom of the remote key, and the mechanical key will automatically pop up. To retract it, hold down the release button while folding

### Notes

- To prevent loss, please keep your keys in a safe place. If a key is lost, you will need to purchase an original KOVE key for matching.

and pushing the mechanical key into the slot until it securely locks into place.

- The mechanical key is used to open the fuel tank lock and seat cushion lock. Insert and turn the key gently to avoid excessive force that may damage the lock cylinder.
- Avoid prolonged exposure to direct sunlight or high-temperature environments.
- Do not grind, drill, or alter the shape of the mechanical key in any way.
- When the remote range decreases, the buttons respond slowly, or the indicator light dims, replace the battery with the same model promptly to prevent leakage that may damage internal circuits.
- Avoid dropping, squeezing, or soaking the key in water. Wipe it dry promptly in humid ambient, and consider using a waterproof key cover for added protection.
- Do not store the key together with hard metal objects (e.g., coins, tools) or strong magnetic items (e.g., mobile phones, induction cookers) for extended periods to prevent signal interference or damage to the casing.

## Storage Box

The motorcycle's front storage box is located in front of the fuel tank lock, providing a convenient place to store keys, towels, change, and other personal items to prevent them from being scattered or forgotten.

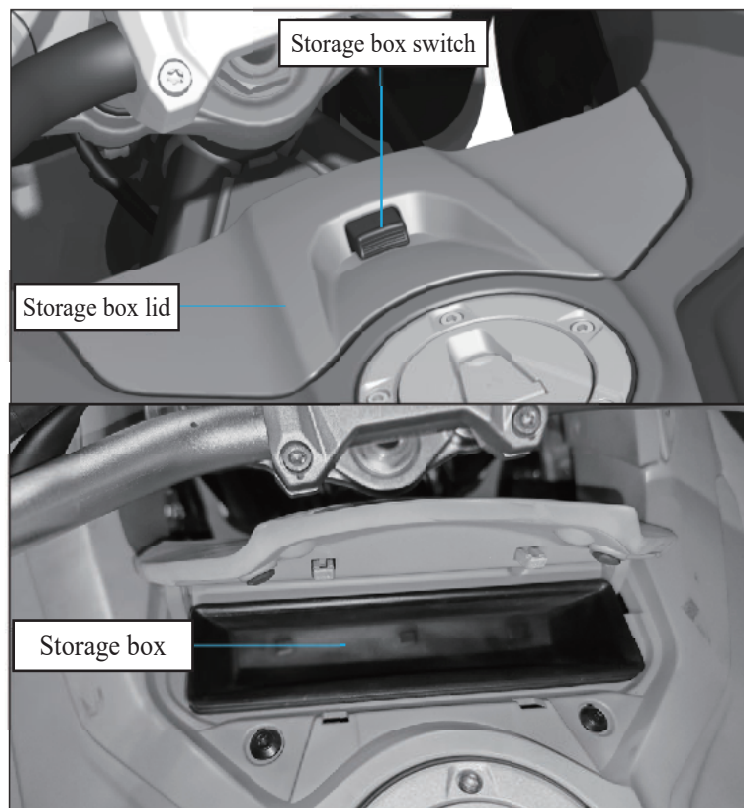

### Opening Method:

- Press the storage box switch and flip upward to open the storage box lid.
- The storage box has limited capacity, so you should plan the item dimensions in advance.
- It is not advisable to leave valuables on motorcycles to prevent loss or theft.
- Close the storage box lid before driving to ensure stored items are secure and stable, preventing them from falling or compromising driving safety during travel.

### **Warning**

- The storage box is located near the fuel tank; avoid storing flammable or explosive items such as lighters.

## Instruments and Millimeter-wave Radar

### Odometer, Trip Meter (Sub-total)

#### Odometer

When the reading exceeds 999,999, the display will lock at 999,999. Trip Meter

When the reading exceeds 999.9, the display will automatically reset to zero.

### Millimeter-wave Radar

The rear of the motorcycle is equipped with millimeter-wave radar sensors, enabling the following assisted driving functions:

- ① LCA (Lane Change Assist) – Assists the rider in determining the appropriate timing for lane changes;
- ② RCW (Rear Collision Warning) – Alerts the rider of vehicles approaching from behind to reduce the risk of rear-end collisions
- ③ BSD (Blind Spot Detection) – Compensates for limited rider visibility and issues warnings for targets in the blind spot.

Every time the vehicle is powered on, the rear mirror radar indicator light flashes twice for self-test. If there is no self-test or the indicator light does not flash after powering on, your radar warning system may be malfunctioning. Please have it inspected and repaired at an authorized KOVE Motorcycle service center as soon as possible.

## Motorcycle Care

Regular cleaning and polishing ensure a long motorcycle lifespan. A clean motorcycle makes it easier to spot potential faults. It is particularly noteworthy that anti-icing seawater and salt scattered on the road can accelerate corrosion. Be sure to clean the motorcycle thoroughly after driving on the coastal or above-mentioned road.

### Cleaning

Wait for the engine, muffler, brakes, and other high-temperature components to cool before cleaning.

1. Thoroughly rinse the motorcycle with a low-pressure hose to remove loose dirt.
2. If necessary, use a sponge or soft towel dipped in mild detergent to remove dust and dirt.
3. Thoroughly rinse the motorcycle with ample clean water and dry it using a clean, soft cloth.
4. After drying the motorcycle, lubricate the moving parts, ensuring that no lubricant splashes onto the brakes or tires. Oil-contaminated brake discs, brake pads, brake drums, or brake shoes can significantly reduce braking performance and may lead to accidents.
5. After washing and drying the motorcycle, lubricate the drive chain promptly.
6. Waxing helps prevent corrosion.

Avoid using products containing strong detergents or chemical solvents, as these substances can damage the motorcycle's metal parts, paint, and plastic components. Do not wax the tires and brakes.

If your motorcycle has parts with a matte finish, avoid waxing these matte surfaces.

## Cleaning Precautions

- Avoid using a high-pressure water jet:
  - ▶ High-pressure water jets can damage moving parts and electrical components, rendering them irreparable.
  - ▶ Moisture from the intake port may be drawn into the throttle body or enter the air filter.
- Avoid direct water rinsing of the muffler:
  - ▶ Water in the muffler may cause starting problems and rust. If detected, remove all traces and dirt immediately.
- Dry the brakes:
  - ▶ Water reduces braking performance. After washing, intermittently use the brakes at low speed, repeatedly pressing the brake pedal lightly to generate heat from friction, drying the water until braking efficiency is restored.
- Avoid direct water contact beneath the seat cushion:
  - ▶ Water entering under the seat cushion may damage electrical appliance parts.
- Avoid rinsing the air filter directly with water.
  - ▶ If the air filter gets wet, the engine may fail to start.
- Avoid direct water contact near the headlight:

After washing or riding in the rain, the internal lens of the headlight may temporarily fog up, but this does not affect its functionality. However, if you notice a significant accumulation of water or ice inside the lens, have it inspected by an authorized KOVEMOTO Motorcycle service center.
- Avoid waxing or polishing matte finishes:
  - ▶ Use sufficient water and a mild cleanser to clean matte paint surfaces, and dry them with a clean, soft cloth.

### Aluminum Components

Aluminum corrodes when exposed to dirt, mud, or salt. Regularly clean aluminum components and follow these guidelines to prevent scratches:

- Avoid using stiff brushes, steel wool, or any abrasive cleaning materials.
- Do not drive or scrape against the curb.

### Panel

Follow these guidelines to prevent scratches and damage:

- Gently clean with a sponge and sufficient water.
- Clean with diluted detergent and rinse thoroughly with ample water to remove stubborn stains.
- Avoid exposing the instrument panel and lamp covers to corrosive liquids like gasoline and brake fluid.

### Notes

- Remove all traces and dirt immediately upon noticing rust in the muffler.

### Mufflert

The muffler can also get dirty from mud or dust. Use a wet sponge with cleaning agent to remove the mud or dust, then rinse thoroughly with clear water, and dry with suede or a soft towel. If necessary, burn marks can be removed with a commercially available compound of fine texture, and then rinsed in the same manner as mud and dust.

If the muffler is painted, use a neutral detergent to clean the exhaust pipe and the painted surface of the muffler. If you are unsure whether the muffler is painted, contact a authorized KOVEMOTO service center.

## Motorcycle Parking

If you leave your motorcycle outdoors, you should consider using a full motorcycle cover. If you do not ride for an extended period of time, please follow these guidelines:

- Wash the motorcycle and wax all painted surfaces (excluding matte finishes), then apply anti-rust oil to all chrome parts.
- Lubricate the drive chain.
- Place the motorcycle on a maintenance stand and elevate it with wooden blocks to ensure both tires are off the ground.
- After rain, remove the body cover and dry it in a ventilated place.
- Remove the battery to avoid discharging.

Fully charge the battery and store it in a cool, well-ventilated area. If you leave the battery in place, disconnect the negative terminal to prevent discharge. Before reusing a stored motorcycle, inspect all items as specified in the maintenance interval table.

## Motorcycle Transport

If you need to transport your motorcycle, use a motorcycle trailer, loading ramp, or flatbed truck equipped with a lifting platform, and secure it with motorcycle tie-down straps. Never attempt to tow a motorcycle with its wheels on the ground.

### Notes

- Towing a motorcycle can severely damage the drivetrain.

## You and Your Environment

Owning and riding a motorcycle is an enjoyable experience, but you must take responsibility for protecting the environment.

### Select the appropriate detergent

Use biodegradable detergents when washing your motorcycle, and avoid sprays containing chlorofluorocarbons (CFCs) as they harm the protective ozone layer in the atmosphere.

### Waste Recycling

Sort the oil and other toxic wastes into approved containers and send them to the recycling center. Call the local national public affairs or environmental service office for the recycling center in your area and the disposal method of non-recyclable wastes. Do not pour used engine oil into trash cans, sewers or ground, because the used oil, gasoline, coolant and cleaning solvent contain toxic substances, which will hurt cleaners, pollute drinking water, lakes, rivers and seas.

## Vehicle Identification Number, Engine Number and Nameplate

When registering a motorcycle, you must provide the vehicle identification number and engine number. These unique identifiers are used to distinguish your motorcycle. When ordering replacement parts, ensure you record these numbers and store them in a secure location.

### Vehicle Identification Number (VIN)

The VIN is engraved on the right side of the frame upright tube

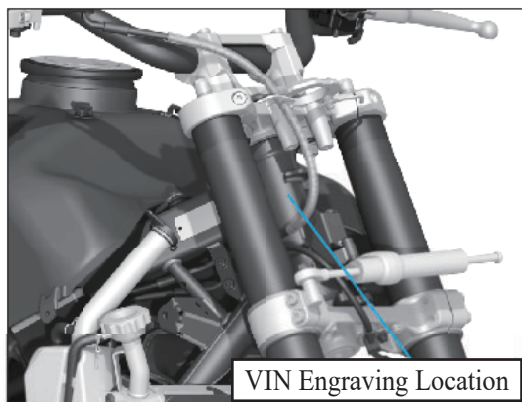

### Engine Number

The engine number is engraved on the crankcase, which locates at the right side of crankcase

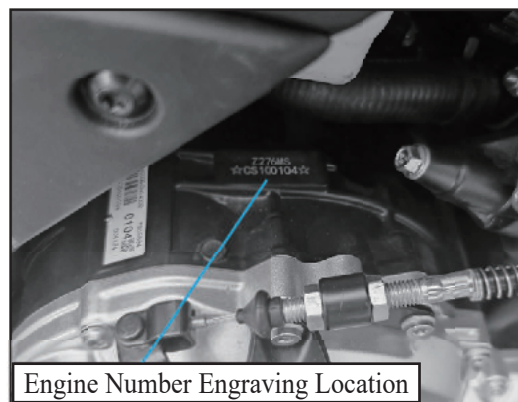

### Nameplate

The nameplate is riveted to the right side of the main frame beam tube.

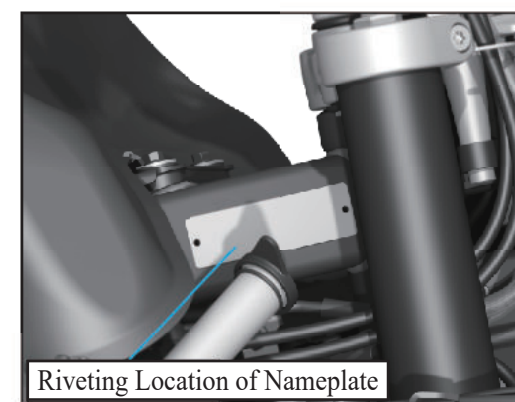

## Catalytic Converter

This motorcycle is equipped with a three-way catalytic converter. The catalytic converter contains precious metals as catalysts for high-temperature chemical reactions, transforming hydrocarbons (HC), carbon monoxide (CO), and nitrogen oxides (NO<sub>x</sub>) in the exhaust into compliant mixtures.

A faulty catalytic converter can pollute the air and reduce your engine's performance. When replacing it, always use genuine Buick motorcycle parts.

Follow these guidelines to safeguard your motorcycle's catalytic converter:

- Only unleaded gasoline should be used, as leaded gasoline can damage the catalytic converter.
- Maintain the engine in optimal operating condition.
- If the engine fails to start, backfires, stalls, or exhibits other poor performance, stop riding immediately and turn off the engine. Have the motorcycle inspected by an authorized KOVEMOTO motorcycle service center.

# Technical Parameters

Vehicle-Related Parameters .....	92
Torque Parameters .....	94
Frame Tightening Torque.....	95

**Vehicle-Related Parameters -1**

Vehicle Model	KY600GY	Engine Model	Z276MS
Overall length (mm)	2290	Cylinder diameter (mm) × Stroke (mm)	76.0×64.0
Overall width (mm)	935	Compression ratio	11.5:1
Overall height (mm)	1395	Maximum power (kw/r/min)	47.0 ± 2% / 8500 ± 1.5%
Wheelbase (mm)	1495	Maximum torque (N·m/rpm)	57.0 ± 2% / 7000 ± 1.5%
Curb weight (kg)	218	High/low idle speed (rpm)	2400±250/1350±100
Payload (kg)	175	Cylinder capacity (mL)	581
Carrying capacity	2 person	Spark plug	CPR8EA-9 (NGK)
Front tire specifications	110/80R19	Spark plug gap (mm)	0.8-1.0
Rear tire specifications	150/70R17	Valve clearance (mm)	Intake valve: 0.10-0.15
Maximum speed (km/h)	175		Exhaust valve: 0.15-0.20

**Vehicle-Related Parameters - 2**

Lubricating oil capacity (L)	3.4	Main fuse	30A
Fuel capacity (L)	21	Fog lamp, welcome lights	LED lamp
Primary transmission ratio	1.826	Headlight	LED lamp
First gear	3.285	Front position lamp	LED lamp
Second gear	2.105	Rear position lamp/Brake lamp	LED lamp
Third gear	1.600	Front turn signal	LED lamp
Fourth gear	1.300	Rear turn signal	LED lamp
Fifth gear	1.150	Rear license plate lamp	LED lamp
Sixth gear	1.043	Turn indicator light	LED lamp
Final transmission ratio	3.333	Instrument indicator light	LED lamp
Battery	12V8.6Ah (lead-acid battery)	Ignition mode	ECU controls ignition

**Torque Parameters**

Fastener Type	Torque	Fastener Type	Torque
5mm bolt and nut	6	6mm Screw	8
6mm bolt and nut	12	6mm flange bolt (8mm head, small flange)	10
8mm bolt and nut	22	6mm flange bolt (8mm head, large flange)	12
10mm bolt and nut	60	6mm flange bolt (10mm head) and nuts	12
12mm bolt and nut	80	8mm flange bolt and nut	22
5mm screw	5	/	/

**Notes**

- Except for the specified torque, the standard torque values in the above table apply to this vehicle.

### Vehicle Body Bolt Torque

Item	Thread Diameter (mm)	Torque (N·m)	Notes
ABS and ABS bracket	M6	10	
ABS bracket and frame	M6	10	
BCM bracket and frame	M6	10	
ECU and rear fender front section	M5	5	
U swingarm and frame	M10	54	
U swingarm and triangular cradle	M10	54	
Left/right bumper and frame	M8	22	
Left/right bumper and headlight bracket	M8	22	
Side case hoist and side case bracket	M6	10	
Side case bracket mounting bolt	M8	22	
Side case bracket fixing plate and frame	M8	22	
Side case bracket fixing plate and electric deceleration unit	M8	22	High Configuration
Side case bracket guard bar mounting bolt	M8	22	
Adjusting and tightening nut of the shift rod	M6	5	
Shift rod and gear shift pedal	M6	10	
Shift rod and shift rockerarm	M6	10	
Shift pedal assembly and frame	M8	22	
Shift rockerarm and engine gear shift lever	M6	10	
Side windshield and headlight housing	M5	5	
Side windshield and instrument housing	M5	5	

Item	Thread Diameter (mm)	Torque (N·m)	Notes
Side tilt sensor	M5	5	
Frame large panel trim part and frame	M6	10	
Frame engine lower protector right frontbracket and engine	M6	10	
Vehicle body front mounting point and frame	M6	10	
Vehicle body and frame	M6	10	
Water reservoir and radiator	M6	10	
Storage box cover and inner lining	ST4.2	1	
Storage box and fuel tank	M6	10	
Ground wire and frame	M6	10	
Headlight bracket and frame	M8	22	
Rear sprocket connected to buffer	M8	35	
Idle stepper motor mounting screw	ST4.8	2	
Idle stepper motor mounting base	M5	4	
Windshield grille and fuel tank side protector	M5	5	
Front section of air deflector and frame	M6	10	
Battery box and battery box bracket	M6	10	
Battery positive and negative wire bolt	M5	4	
Electronic lock assembly and upper connecting plate	M8	22	
Regulating rectifier and frame	M6	10	
Engine heat shield connected to engine	M6	11	
Engine fuel drain bolt	M12	28	

Item	Thread Diameter (mm)	Torque (N·m)	Notes
Engine rear upper suspension	M10	60	
Engine rear lower suspension	M10	60	
Engine front suspension (left and right) and frame	M10	60	
Engine upper suspension (left and right) and frame	M10	60	
Engine lower protector and engine lower protector right front bracket	M6	10	
Engine lower protector and engine lower protector left front bracket	M6	10	
Engine lower protector and muffler front section, left rear bracket	M6	10	
Engine lower protector left rear bracket and frame	M6	10	
Engine lower protector left front bracket mounting bolt	M6	10	
Engine sprocket cover and engine	M6	10	
Engine front sprocket locking bolt	M10	45	
Steering handlebar counterweight mounting bolt	M6	8	
Steering handlebar upper clamp and lower socket	M8	22	
Steering stem locking nut	M24	108	
Height position sensor mounting bolt	M6	10	High Configuration
Millimeter-wave radar mounting nut	M6	6	
Rear fender rear section bracket weld assembly and frame	M6	10	
Rear fender rear bracket weld assembly and rear fender rear section	M5	5	
Rear fender rear bracket and vehicle body left and right	M5	5	
Rear fender inner panel and rear fender rear bracket	M5	5	
Rear mounting point of front section of rear fender	M6	10	

Item	Thread Diameter (mm)	Torque (N·m)	Notes
Front mounting point of front section of rear fender	M5	5	
Rear disc brake and rear wheel hub	M8	30	
Rear reflector	M6	6	
Rear grab handle mounting bore and frame	M10	44	
Rear grab handle front mounting bore and frame	M8	22	
Rear shock absorber controller and battery box	M6	10	High Configuration
Rear shock absorber guard and front section of rear fender	M5	5	
Rear shock absorber spring pre-load locking nut	/	12	
Rear shock absorber upper to frame	M10	45	
Rear shock absorber lower and triangular cradle	M10	45	
Rear shock absorber wire clip and swingarm	M6	8	
Rear footpeg bracket assembly -left/right and frame	M8	22	
Rear wheel speed sensor mounting	M6	10	
Rear wheel front fender and fender bracket	M5	3	
Rear wheel front fender bracket and rear brake caliper bracket	M6	10	
Rear wheel front fender bracket with chain adjuster - right	M6	10	
Rear wheel axle locking nut	M20	128	
Rear license plate mounting nut	M5	5	
Rear tailgate and vehicle body	M6	10	
Rear brake pump rod end bearing and brake arm	M6	10	
Rear brake pump push rod adjusting and tightening nut	M5	6	

Item	Thread Diameter (mm)	Torque (N·m)	Notes
Rear brake pump and frame	M6	10	
Rear brake switch	M10	32	
Rear brake pedal and brake rockerarm	M5	5	
Rear brake fluid reservoir and frame	M6	10	
Rear Brake hose and swingarm	M5	5	
Spark plug installation	M10	16	
Oil Filter Cover	3/4-UNF (2B)	12	
Engine oil filter connector	M20	27	
Oil pressure sensor	M10	11	
Accelerometer bracket and front shock absorber	M6	10	
Oiler mounting screw	ST4.8	2	
Throttle valve locking pipe clamp screw	M5	3	
Thermostat cover mounting bolt	M6	11	
Intake pipe locking pipe clamp screw	M5	3	
Air filter element mounting screw	ST4.2	1	
Air filter element cover mounting screw	ST4.2	1	
Upper and lower housing of air filter	ST4.2	1	
Air filter and throttle valve	M5	5	
Air filter and seat cushion bracket	M6	10	
Horn and frame	M6	10	
Cooling pump cover mounting bolt	M6	11	

Item	Thread Diameter (mm)	Torque (N·m)	Notes
Cooling pump pipe connector mounting bolt	M6	11	
Cooling pump drain bolt	M6	11	
Clutch lever assembly mounting bolt	M6	10	
Chain guard and swingarm	M6	10	
Chain adjuster locking nut	M8	16	
Chain clip with swingarm	M6	8	
License plate lamp pressure plate	ST3.5	1	
Swingarm shaft locking nut	M16	88	
Swingarm axle trim and frame	M6	10	
Cylinder head drain bolt	M6	11	
Front/rear wheel spokes	M5	6	
Headlight housing and headlight assembly	M5	5	
Headlight housing and front upper fender assembly	M5	5	
Front headlight assembly and headlight bracket	M6	10	
Front windshield upper bracket and lower bracket	M6	6	
Front windshield lower bracket and headlight housing	M6	10	
Front windshield and front windshield upper bracket	M5	6	
Front fender assembly and front shock absorber bottom cylinder	M6	10	
Front disc brake and front wheel hub	M8	30	
Front and rear oil reservoir filler cap fastening bolt	M5	2	
Front shock absorber lower cylinder locking front wheel axle	M8	22	

Item	Thread Diameter (mm)	Torque (N·m)	Notes
Front shock absorber adjuster end cover bolt	M8	22	
Front shock absorber damper inner rod and regulator end cap tightening nut	M6	15	
Front footpeg bracket - L/R and frame	M8	22	
Front wheel speed sensor and front shock absorber bottom cylinder	M6	10	
Front wheel axle locking	M16	70	
Front upper fender - L/R and front upper fender trim	M5	5	
Front upper fender - L/R and fuel tank side protector	M5	5	
Front upper fender lower protector and lower connecting plate	M5	5	
Front upper fender trim and headlight housing	M5	5	
Front upper fender trim assembly and headlight bracket	M6	10	
Front position lamp assembly	ST4.2	1	
Externally mounted drive box for front fog lamp	ST3.5	1	
Front brake pump mounting bolts	M6	10	
Front brake caliper and shock absorber bottom cylinder	M10	45	
Front seat cushion and frame	M6	8	
Fuel pump and fuel tank	M5	5	
Three-in-one sensor mounting screw	ST4.8	2	
Triangular cradle and swingarm	M10	54	
Radiator fan and radiator	M6	10	
Radiator upper mounting point and frame	M6	10	
Brake rockerarm and frame	M8	22	

Item	Thread Diameter (mm)	Torque (N·m)	Notes
Upper bracket wire hook	M5	6	
Upper bracket and front shock absorber (locking)	M8	22	
Camera bracket	ST4.2	1	High Configuration
Handlebar grip - left and handlebar tube	M4	5	
Handlebar switch - left/right mounting screw	ST4.8	2	
Hand-operated windshield left and right cover cap nuts	M6	4	
Double-threaded stud to lower socket of steering handlebar	M10	30	
Double-threaded stud and upper bracket locking nut	M8	22	
Water pump mounting bolt	M6	11	
Extension bracket and front windshield lower bracket	M6	10	
Taillight assembly and frame	M6	10	
Top case mushroom mounting bolt	M6	10	
Top case latch mounting bolt	M6	10	
Top case and rear grab handle	M8	22	
Top case bracket mounting bolt	M8	22	
Fog lamp bracket - L/R and headlight bracket	M6	10	
Fog lamp bracket - L/R and fog lamp assembly	M6	10	
OFF switch and side stand	M6	10	
Lower protector and lower protector bracket	M6	10	
Lower protector - L/R and lower protector	M6	10	
Lower bracket and front shock absorber (locking)	M8	22	

Item	Thread Diameter (mm)	Torque (N·m)	Notes
Muffler pipe clamp	M8	22	
Muffler rear section and rear footpeg assembly - right	M8	22	
Muffler shield and muffler	M6	10	
Muffler front section and frame	M8	22	
Muffler front section and engine	M8	22	
Oxygen sensor wire hook and engine	M5	6	
Oxygen sensor connected to muffler front section	M12	20	
Instrument housing and headlight housing	M5	5	
Instrument housing and adjustment base	M5	5	
Instrument bracket and instrument	M5	5	
Fuel rail and throttle valve	M6	10	
Accelerator cable A/B (steering handlebar end)	M5	4	
Accelerator cable A/B (throttle end)	M5	6	
Accelerator cable and oiler	M5	3	
Fuel tank side protector and fuel tank	M6	10	
Fuel tank rear mounting point	M8	22	
All connecting screws of fuel tank protector assembly	ST4.8	1	
Fuel tank front mounting point	M6	10	
Fuel tank upper protector and fuel tank	M6	10	
Fuel tank lock mounting bolt	M5	6	
Fuel tank lower protector, frame, and radiator assembly	M6	10	

Item	Thread Diameter (mm)	Torque (N·m)	Notes
Fuel tank lower protector and front upper fender assembly	M5	5	
Fuel tank lower protector and fuel tank side protector	M5	5	
Fuel tank lower protector and fuel tank lower protector trim	ST4.2	1	
Fuel tank middle protector, side protector and fuel tank	M6	10	
Brake caliper bleed screw	M5	6	
Brake hose 1 and ABS	M10	32	
Brake hose 1 and frame	M6	10	
Brake hose 1 and front brake pump	M10	28	
Brake hose 2, 5 and front brake caliper	M10	28	
Brake hose 2 and ABS	M10	32	
Brake hose 2 and frame	M6	10	
Brake hose 2 and lower connecting plate	M6	10	
Brake hose 3 and ABS	M10	32	
Brake hose 4 and ABS	M10	32	
Brake hose 4 and rear brake caliper	M10	28	
Main cable and rear fender rear section	ST4.2	1	
Seat cushion lock base and frame	M6	10	
Seat cushion bracket and frame	M6	10	
8-slot adjusting nut	M25	First stage: 40N·m, second stage: loosen the adjusting nut by two turns and then tighten it to 10N·m, third stage: keep the direction fixed and loosen by 1/4 turn	

Item	Thread Diameter (mm)	Torque (N·m)	Notes
Side bracket and frame	M10		Fasten the bolt to 10 N·m and loosen by 1/3 turn, then hold the bolt head steady and tighten the locking nut to a torque of 22 N·m





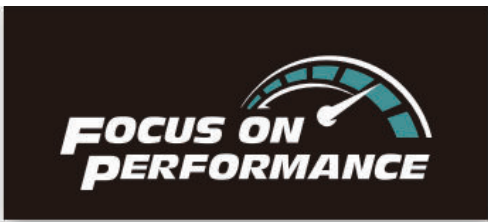

<https://www.kovemoto.com>

Tibet New Summit Motorcycle Co., Ltd. All rights reserved.

Version: 11/2024