

To our distinguished owner

KY600 International Version/Euro 5+ Two-Wheel Motorcycle Instruction Manual First Edition (March 2025)

First of all, congratulations on your purchase of a brand new KOVEMOTO!

By choosing KOVEMOTO motorcycles, you become part of the KOVEMOTO motorcycle family.

This Instruction Manual introduces the main specifications, basic structure, adjustment method and maintenance knowledge of the motorcycle. It will guide you to master the basic operation of the motorcycle and eliminate or reduce common faults, which can effectively ensure driving safety, play the best performance of the vehicle, and improve the service life of the vehicle.

**This Instruction Manual contains the introduction of the basic configuration of the motorcycle. The contents and pictures are for reference only, please refer to the physical object.**

**Due to the production time, user needs and design improvements, the actual motorcycle may be different from the contents of the Manual. We reserve the right to make changes at any time, and we will no longer notify and assume any obligations. Sorry for any inconvenience caused.**

The Instruction Manual is one of the necessary accessories of the motorcycle, and when it is sold to others, it should be attached to the motorcycle.

The copyright of this Instruction Manual belongs to the company, and no reproduction is allowed without the written consent of the company, and violators will be prosecuted.

To ensure your safety, and increase your riding pleasure:

- Please read the Instruction Manual carefully.
- Please follow all recommendations and procedures in the Instruction Manual.
- Please pay close attention to the safety information recorded in the Instruction Manual and pasted on the motorcycle body.

## Safety Precautions

The safety of you and others is very important, and the safe driving of this motorcycle is an important responsibility. To help you make an informed decision about your safety, we provide steps and other information on the safety label and in the Instruction Manual to remind you. This information is intended to alert you to the potential danger of harm to you or others.

It is impractical for us to list all the hazards associated with motorcycle riding and maintenance, and you must make the right judgment yourself.

It is forbidden to install electrical equipment, because the battery used in the motorcycle equips with a relatively low capacity, and the installation of electrical equipment may cause a loss of power.

The motorcycle is equipped with a high-speed engine. For your driving safety, it is recommended that you reduce violent driving.

You'll see important security information in a variety of forms, including:

- Safety labels on the body of a motorcycle;
- The safety information is preceded by a safety warning symbol  and one of the following three warnings : Caution, Danger, and Warning.

**The meanings of the three warnings are as follows:**

 **Caution** - If you do not follow the instructions, you may be injured.

 **Danger** - If you do not follow the instructions, you will cause serious casualties.

 **Warning** - If you do not follow the instructions, you will cause serious casualties.

Other important information is listed under the following headings:

**Notes** - Information to help you avoid damage to your motorcycle, other property, or the environment.

## Contents

Motorcycle Safety ..... 4

User Manual ..... 13

Maintenance ..... 29

Fault Handling ..... 55

Relevant Information ..... 65

Technical Parameters ..... 75

# Motorcycle Safety

**This section contains important information about the safe riding of motorcycles, please read this section carefully.**

Safety Instructions .....	5
Safety Precautions.....	8
Riding Precautions .....	9
Spare Parts and Modifications .....	12
Loading Guide .....	12

## **Safety instructions**

To enhance your driving safety, please follow these guidelines:

- Perform all routine and routine inspections as specified in the Instruction Manual.
- Before filling the tank, turn off the engine and keep away from sparks and open flames.
- Do not start the engine for a long time in a closed or semi-closed space, because the exhaust gas contains carbon monoxide, which is a toxic gas and can be fatal.

## **Always wear a helmet**

It has been proven that helmets and protective clothing can significantly reduce the chance of injury to the head and other parts, and reduce the degree of injury. Therefore, please be sure to wear a certified motorcycle helmet and protective clothing when driving.

## **Before the ride**

Make sure you're in good physical condition, paying attention, and not drinking or taking medication. Make sure that you and your passengers are wearing a certified motorcycle helmet and protective clothing. Make sure your passenger to firmly grip the passenger handholds or hold your waist, place his/her feet on the pedals, and lean with you when you turn, even when the motorcycle is stopped.

## **Take time to study and practice**

Even if you have driven other motorcycles, you should practice riding this motorcycle in a safe area to familiarize yourself with the operation and operation of this motorcycle and adapt to the size and weight of the motorcycle.

## **Have a sense of protection when riding**

Always pay attention to the vehicles around you, do not think that other drivers can see you, always be prepared to make emergency brakes or avoid detours.

## Make yourself easier to see

Especially at night, wear bright reflective clothing to make yourself more eye-catching, stop so that other drivers can see you, turn on the signal light before turning or changing the lane, and when necessary, use the horn to remind pedestrians.

## Don't drink and ride

Alcohol and driving are not compatible. Never exceed your personal ability when driving, and do not exceed the speed specified by the vehicle, fatigue and negligence will weaken your ability to make correct judgments and safe driving.

## Keep your motorcycle in a safe state

It is important to take good care of your motorcycle so that your motorcycle is always in good condition. Check your motorcycle before each ride and complete all recommended maintenance and repairs. **Do not modify motorcycles or add accessories that will affect safety without authorization, and overload is strictly prohibited.**

## Dealing with incidents

Your personal safety is your first priority. If you or anyone else is injured, you should first carefully evaluate the severity of the injury and determine whether it is safe to continue driving, and call for emergency assistance if necessary. If other persons or vehicles are involved in a collision, the applicable local laws and regulations should also be followed.

If you decide to continue driving, first turn the ignition switch to the "OFF" position, and then evaluate the condition of the motorcycle. Check whether there is oil leakage, check whether the key nuts and bolts are fastened, and check the steering handlebar, steering stem, brake and wheel to ensure that the personnel and vehicle are safe. Please drive slowly and carefully.

Your motorcycle may have suffered damage that will not be immediately apparent, please submit it to an authorized KOVEMOTO motorcycle service center or a qualified special repair shop for a thorough inspection as soon as possible.

## Carbon monoxide hazard

The exhaust gas contains toxic carbon monoxide, a colorless and odorless gas, and inhaling higher concentrations of carbon monoxide can cause people to lose consciousness and may even be fatal.

Do not start the engine for long periods of time in a garage or other enclosed space.

### Warning

- If the engine is started for a long time in a closed or semi-closed space, it may cause a rapid accumulation of toxic carbon monoxide gas.
- Inhaling this colorless, odorless gas causes rapid loss of consciousness and death.
- Motorcycle engines should only be started in well ventilated outdoor areas.

## Safety Precautions

- Be careful when riding, always keep your hands on the throttle grips and your feet on the pedals.
- Make sure your passenger to firmly grip the passenger handholds or hold your waist, place his/her feet on the pedals.
- Always pay attention to the safety of riders, passengers and other drivers on the road.

## Protective clothing

Make sure that you and any accompanying passenger are wearing a certified motorcycle helmet, goggles and eye-catching protective clothing, and drive carefully according to the weather and road conditions.

### ■ Helmet

It is certified to safety standards, eye-catching, and sized to fit your head size.

- It must be safe and comfortable and secured with a chin strap.
- It does not obstruct the line of sight of the mask or other certified goggles.

### ■ Gloves

High-wear-resistant full-finger leather gloves.

### ■ Boots or riding shoes

Boots that are strong and slip-resistant and protect the ankle.

### ■ Clothing

It includes a protective eye-catching long-sleeved shirt suitable for riding and wear-resistant pants (or protective suits).

### ▲ Warning

- Not wearing a helmet increases the chance of serious injury in an accident.
- Make sure that you and your passengers always wear certified helmets and protective clothing.

## Riding precautions

### Run-in period

Follow these guidelines during the first 1000 km of driving to ensure the motorcycle's later reliability and performance.

- Avoid full throttle start or rapid acceleration.
- Avoid emergency braking and rapid downshifting.
- Ride carefully.

### Brake

**Follow the following guidelines:**

- Avoid excessive emergency braking and downshifting
  - ▶ Sudden braking will reduce the stability of the motorcycle.
  - ▶ Slow down before turning, or you may slip.
- Be careful when driving on slippery roads
  - ▶ Tires are easier to slide on slippery surfaces and require longer braking distances.
- Avoid continuous braking
  - ▶ In the long and steep slope down the slope, repeated braking will lead to serious overheating of the brake, affecting the braking effect. You should use the engine brake and use the brake intermittently to slow down.
- The front and rear brakes can be used at the same time to achieve a complete braking effect.

### ■ Anti-lock brake system (ABS)

This model is equipped with an anti-lock braking system to prevent tire lock-up during emergency braking. When the vehicle speed is less than 5 km/h, the anti-lock braking system does not work.

- During braking, after ABS intervention, the brake handle or Foot brake lever may slightly rebound, which is a normal phenomenon.
- Always use the recommended tires to ensure that the anti-lock braking system works correctly.

### ■ Engine brake

When you release the accelerator, the engine braking will help the motorcycle slow down. If you want to slow down further, you can downshift to a lower gear. When going downhill on a long and steep slope, you should use engine braking and apply the brakes intermittently to slow down.

### ■ A humid and rainy environment

In a wet and rainy environment, the road surface will be wet and slippery, and the wet brake will also reduce the braking efficiency. You need to be very careful when braking. If the brake is wet, it can be intermittently repeated during low-speed driving and riding, which helps to dry the brake quickly.

## Parking

- Stay on solid, flat ground.
- If you must stop on a slightly inclined or loose ground, make sure to stop the motorcycle and make sure that the motorcycle cannot move or tip over.
- Ensure that high temperature parts do not come into contact with flammable materials.
- Do not touch the engine, muffler, brake and other high temperature parts before cooling.
- To avoid the possibility of theft, be sure to lock the steering handle and remove the key before leaving the unattended motorcycle.

■ Stop the motorcycle with the side support

1. Extinguish engine.
2. Lower side support.
3. Tilt the motorcycle slowly to the left until its weight is concentrated on the side stand.
4. Turn the steering handle completely to the left.
  - ▶ If the steering handle is turned to the right, it will reduce stability and may cause the motorcycle to fall.
5. Turn the ignition switch to the “LOCK” (locked) position and remove the key.

## Fueling/brake fluid and fuel guide

Follow these guidelines to protect your engine and catalytic converter:

- Use only unleaded gasoline.
- It is recommended to use high octane gasoline. The use of low octane gasoline will reduce the performance of the engine.
- It is not recommended to use ethanol gasoline, which will reduce the performance of the engine.
- Do not use spoiled or contaminated gasoline, or oil-gasoline blends.
- Prevent dirt and water from entering the tank.
- Since the brake fluid has a certain corrosive effect, be sure to avoid splashing into the eyes, adhering to the skin and avoiding contact with nonmetallic materials of the vehicle when adding.

## Spare parts and modifications

We strongly recommend that you do not use any accessories other than KOVEMOTO, and do not modify the original design of the motorcycle, which will cause the motorcycle to be unsafe. Unauthorized modifications to your motorcycle will void your warranty service and result in your motorcycle being unable to legally drive on public roads and highways. Before you decide to add accessories to your motorcycle, first determine which modifications are safe and legal.

**It is prohibited to attach a trailer or a sidecar to a motorcycle and to modify or install other equipment at the engine installation point. Your motorcycle does not have the design of these accessories, and their use will seriously damage the maneuverability and safety of the motorcycle.**

### Warning

- Improper accessories or modifications may cause safety accidents, in which you may be seriously injured or even life-threatening.
- Please follow all instructions in the Instruction Manual for accessories and modifications.

## Loading guide

- The additional load will affect the maneuverability, braking and stability of the motorcycle. When riding with heavy loads, be sure to maintain a safe speed.
- Please keep within the specified loading limit, the maximum payload of the whole vehicle is 150kg, do not overload.
- Fix all luggage and place it evenly and smoothly near the center of the motorcycle.
- Do not place objects in the headlights or Mufflers.

### Warning

- Overloading or improper loading will lead to accidents, resulting in serious casualties.
- Please follow the loading instructions in the Instruction Manual.

# User Manual

**This section contains important information about the operation of the motorcycle, please read this section carefully.**

Parts Location Diagram .....	14
Instruments.....	16
Switch .....	22
Ignition Switch.....	24
Start The Engine.....	25
Gear Shifting.....	26
Traction Control Ystem.....	27
Refueling.....	28

## Parts Location Diagram

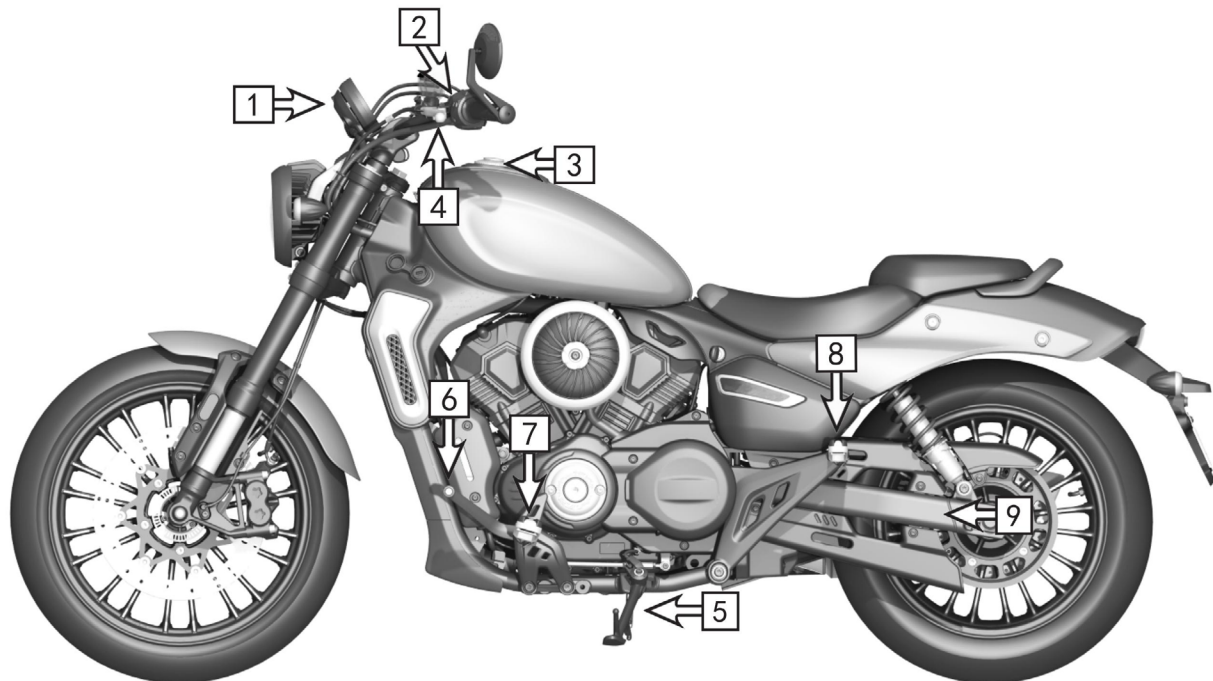

1. Instrument assembly 2. Left combination switch 3. Fuel tank lock 4. Clutch lever 5. Side stand 6. Shift pedal 7. Front footpeg assembly-left 8. Rear footpeg assembly-left 9. Swingarm

## Parts Location Diagram

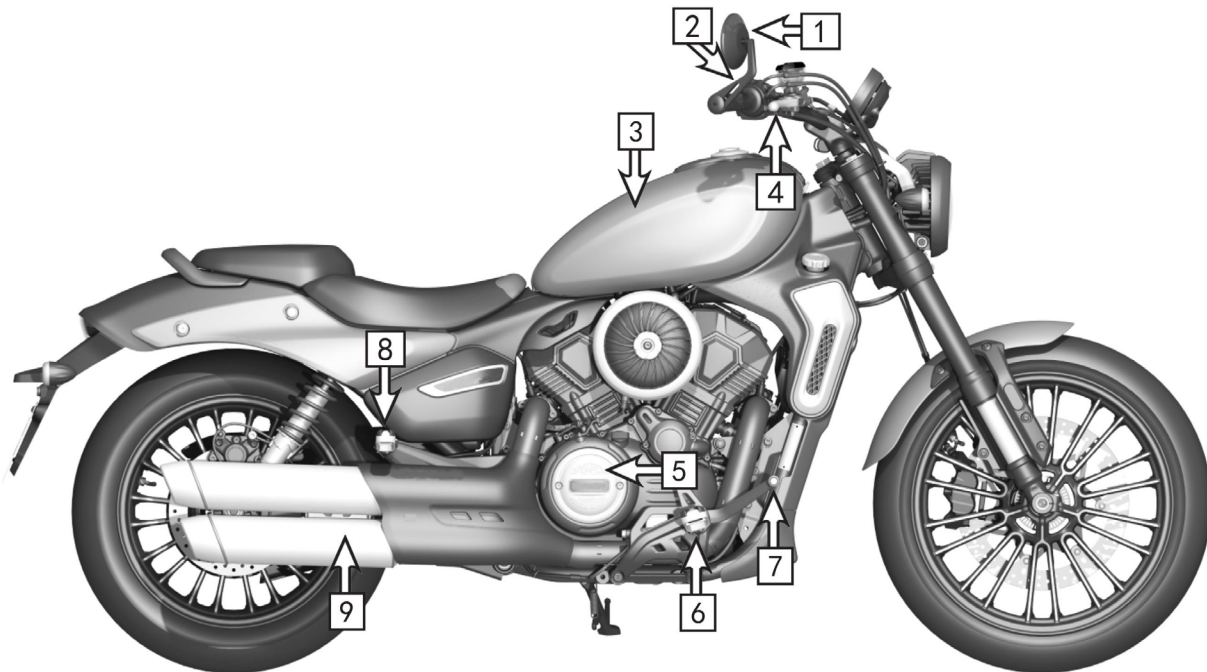

1. Rear view mirror 2. Right combination switch 3. Fuel tank 4. Front brake lever 5. Engine 6. Front footpeg assembly - right 7. Rear brake pedal 8. Rear footpeg assembly-right 9. Muffler

## Instruments

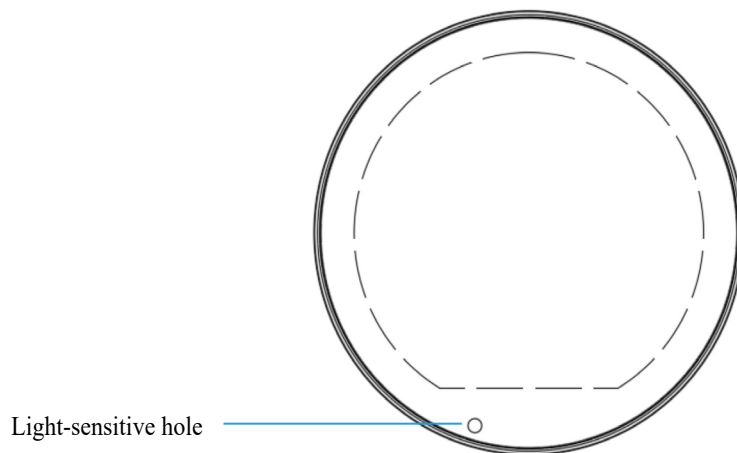

### Display check

When the ignition switch is turned to “ON”, the instrument is powered on to play the start-up animation, and then self-test is performed, and all functional modules and symbols are displayed. If the display is missing during self-test, Please go to a KOVEMOTO motorcycle authorized repair shop for inspection or maintenance.

## Instrument interface Description

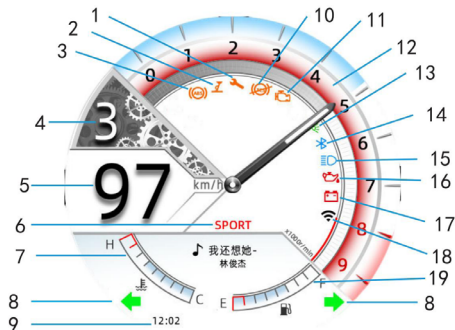

SN	Name	Functional Description
1	Service indicator light	When the motorcycle reaches the maintenance setting condition, this lamp turns on
2	Side stand switch	When the side stand is down, this light turns on
3	ABS malfunction indicator light	① After the vehicle is powered on, it is normal for this light to flash (slow flashing); when the vehicle speed exceeds 5 km/h, the indicator extinguished. ② When ABS mode is disabled, the icon shows a slash ③ When ABS malfunctions happen while riding, this light illuminates
4	Gear indicator	Display the current gear
5	Speedometer	Current speed display (range: 0-200 km/h)
6	Riding mode	ECO is displayed in economy mode, SPORT is displayed in sport mode
7	Water temperature display	① When the water temperature indicator block displays red and lights up the "water temperature alarm lamp", it means that the water temperature is too high. In the case of ensuring safety, stop for inspection, and continue driving after the water temperature drops ② When the water temperature data is abnormal, all water temperature blocks and icon simultaneously flash

SN	Name	Functional Description
8	Turn indicator light	When the left turn signal is on, the left indicator flashes; when the right turn signal is on, the right indicator flashes
9	Time display	Displays the instrument time
10	TCS Indicator	① When the TCS function is disabled: the icon shows a slash. ② When TCS malfunctions happen while riding, this light illuminates ③ When TCS Intervenes: indicator flashes
11	Electronic injection malfunction indicator light	When the electronic injection system fails, this lamp lights up (after the engine is powered on and started normally, the failure lamp goes out as a normal phenomenon)
12	Tachometer	Engine rpm display (range: 0-9,000 RPM)
13	Position indicator light	After the vehicle is powered on, the indicator will illuminate once the position lamp is on.
14	Bluetooth display	When connected to a phone bluetooth, this light turns on.
15	High beam indicator	When the high beam is switched on, this light turns on
16	Oil pressure indicator	When the oil pressure is insufficient, this light turns on
17	Battery warning light	When the voltage is too low or too high, this light turns on
18	Network indicator	When connected to WIFI, this light turns on
19	Fuel display	Displays oil level of fuel ① When the oil level is below one bar, please replenish the fuel as soon as possible ② If the fuel symbol and oil level flash simultaneously, it indicates abnormal oil level signal. Please visit an authorized KOVEMOTO motorcycle service center for inspection as soon as possible

## Menu Instructions-1

Level 1 Menu	Level 2 Menu	Level 3 Menu	Description
Vehicle Information	Trip information	Trip mileage	Sub-total mileage: The range is 999.9 km. It will auto-reset when exceeding the range. To manually reset,
		Riding time	long-press the SET button in the trip information interface.
		Trip fuel consumption	Ride time ~ 0h 00m
		Avg. speed	Trip fuel consumption: Fuel consumption data is reset when the sub-total mileage is reset Avg. speed ~-km/h
	Total Information	Range	Display total vehicle mileage and trip mileage, average fuel consumption
	Average fuel consumption		
	Fault Information	/	/
Vehicle Settings	Riding mode	ECO	Set the engine power output mode (SPORT: sport mode, ECO: economy mode), and the riding mode has a memory function
		SPORT	
	ABS settings	Front/Rear ABS Off	Set ABS operating mode; the current ABS status is displayed through the instrument icon (when ABS is deactivated, the icon shows a slash)
		ON	
		Rear ABS Off	
	TCS settings	ON	Set TCS operating status (the icon displays a slash when TCS is disabled)
		OFF	
		Always OFF	
	Maintenance setting	/	<p>1) When the cursor is on the area of "maintenance mileage settings", "long-press the confirm button" to adjust the mileage. This operation is invalid before the second guarantee. (The mileage flashes at 1Hz, with a default value of 5000km and a range of 500–9999km.) Use the up/down keys to adjust (in 500km increments; each press increases/decreases by 500km). "Short-press the confirm button" to confirm the settings and stop the flashing. The maintenance settings will refresh and recalculate.</p> <p>2) When the cursor is on the area of remaining service mileage, "long-press the confirm button" to clear Maintenance Information (including maintenance mileage and maintenance interval); when the indicator is extinguished, the next maintenance interval will begin.</p> <p>3) When the cursor is on the area of "time settings", "long-press the confirm button" to adjust the maintenance time (flashing frequency: 1Hz, default: 180). Use the up/down keys to adjust (180 and 365). "Short-press the confirm button" to confirm the settings and stop the flashing.</p>

## Menu Instructions-2

Level 1 Menu	Level 2 Menu	Level 3 Menu	Description
Vehicle Settings	Display mode	Auto	Users can choose the day and night UI mode that has been used according to their preferences, and the factory default is automatic
		Night	
		Day	
	Theme settings	Sport	Users can choose the main instrument interface they always use based on their preferences.
		Vintage	
	Brightness settings	Auto	Users can choose the screen brightness level that has been used according to their own preferences, and the factory default is automatic.
		1	
		2	
	Time settings	24H	Users can set the time mode according to their preferences
		12H	
	Language settings	Chinese	Switch between Chinese/English/Spanish menus
		English	
		Spanish	
Mileage settings	Metric	Metric/Imperial unit conversion	
	Imperial		
Equipment information	/		
Music	/	/	After interconnection to your mobile phone, on the Music playback screen, press "Up" to switch to the previous track, press "Down" to switch to the next track, press "Confirm" to pause or resume playback, and press "Back" to exit the interface
Phone	/	/	After connecting to the phone, the Contacts will be displayed. Press "Confirm" to make a call, and press "Back" to end the call. Set up Emergency Contacts: Go to the Contacts Settings → Long press the SET button to configure (up to two emergency contacts can be saved).

## Menu Instructions-3

Level 1 Menu	Level 2 Menu	Level 3 Menu	Description
Bluetooth Connection	/	/	Set up Bluetooth connection with your phone, select the device name that is paired with your phone and long-press the SET button to delete it
Mobile Connectivity	/	/	Set up WIFI connection with the phone (to ensure normal connection, the dedicated APP on the phone needs to enable permissions as prompted; when using WIFI connection, do not choose to use instrument WIFI for internet access, otherwise it will affect the phone's internet function).

## The instrument functions are as follows:

### Vehicle data viewing:

Press the SET key to enter the instrument menu. Vehicle-related data can be viewed through "Vehicle Information".

**Shortcut Buttons (In interfaces accessed via shortcuts, "short press the Back button" to return directly to the main interface):**

1. Long-press the Up button - When phone screen projection is active, directly enter navigation; when not active, enter the WIFI connection interface.
2. Long-press the BACK button - Directly switch to Riding modes.
3. Long-press the SET button - Switch to the Music interface.
4. Long-press the Down button - Switch to the Contacts interface.

### Function setting:

Press the SET key to enter the instrument menu. Parameters such as riding mode (SPORT or ECO), ABS mode, TCS setting, display mode, instrument brightness, ride data, time, and language can be configured via the human-machine interactive menu.

### Instrument and mobile phone interconnection:

1. The navigation function, automatic time function and other functions in the TFT instrument can only be realized after interconnection with the mobile phone installed with the relevant APP.
2. Steps to install the phone APP: ① Enter instrument setting menu; ② Select connection settings; ③ Choose phone interconnection, use a phone connected to the internet to scan the QR code on interface, and download and install the APP as prompted (for a better user experience, please refer to the APP usage guide when using the phone APP).
3. When the instrument needs to be disconnected from the phone, enter the phone resetting menu and select Disconnect WIFI.

### Notes

- If you need to modify the ABS mode or TCS mode, it must be conducted while the vehicle is parked.

## Switch

### Left Combination Switch

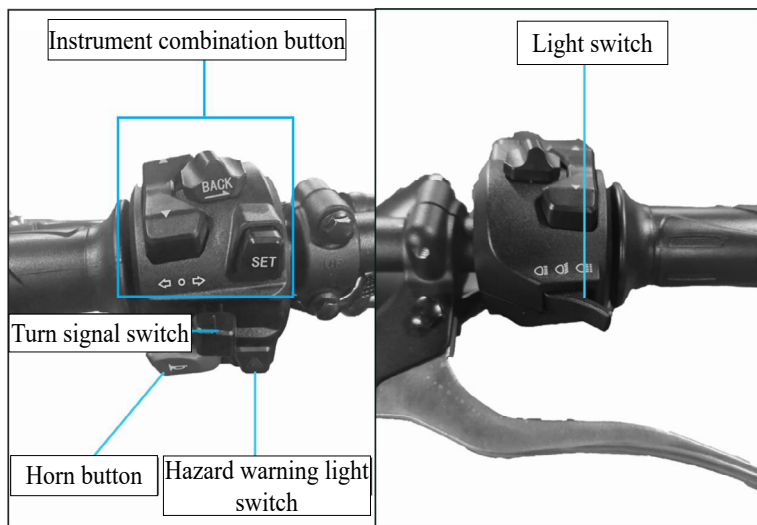

#### Light switch

The light switch is located on the back of the handlebar switch.

- ☰☐ Turn on the headlight flasher
- ☷☐ Turn on the high beam
- ☶☐ Turn on the dipped beam

#### Menu switch:

This combination button is used to set different functions of the instrument.

▲▼: Switch up and down

BACK: Back button

SET: Confirm button

※: Long-press the corresponding button above to access its shortcut function

#### Hazard warning light switch:

⚠ Use in emergency situations. When pressed, it simultaneously activates the left and right turn signal.

#### Turn signal switch:

⇐ Turn on the left turn signal: toggle the switch to the left, and the turn signal switch returns to its original position after operation.

⇒ Turn on the right turn signal: toggle the switch to the right, and the turn signal switch returns to its original position after operation.

○ Turn off the turn signal: When the turn signal switch is in the middle position, press this button to turn off the turn signal.

## Right Combination Switch

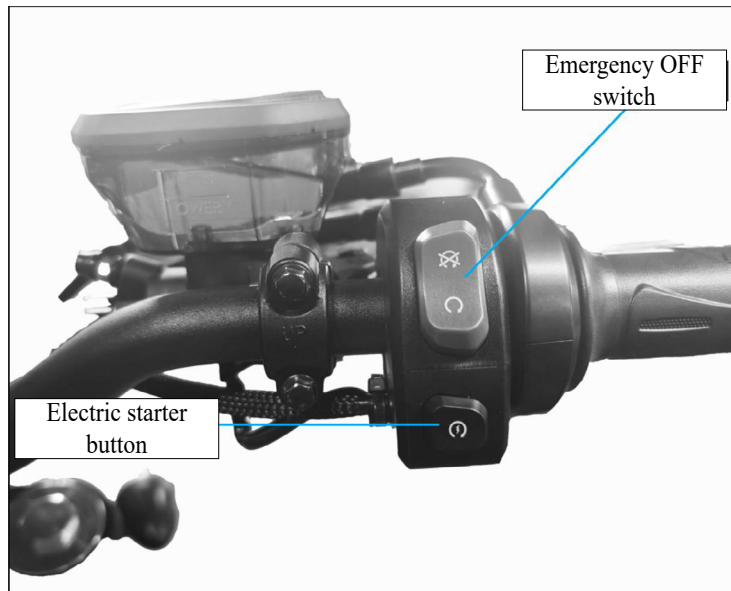

### Emergency OFF switch:

Only when the switch is in "○"(ON) position, the engine can be started;

When the switch is in "⊗"(OFF) position, the engine cannot be started.

▶ In case of emergency, switch to the "⊗" (stop) position to extinguish the engine.

### Electric starter button:

When the OFF switch is set to "○" position:

- ① If the engine is in neutral, press the "⊗" button to start the engine.
- ② If the engine is not in neutral, users should retract the side stand and squeeze the clutch handle, then press the "⊗" button to start the engine.

### Notes

- To extend the lifespan of the switch, it is recommended to blow out any accumulated water inside the switch after car washing or heavy rain.

## Ignition Switch

When the key is in the "OFF" position, turn the direction handle to the leftmost, push the key down, and rotate it counterclockwise to the "LOCK" position, and the direction can be locked; if users need to unlock, rotate the key clockwise.



Position	Function	Notes
OFF	Used in parking (vehicle is powered off)	Key can be removed
ON	Used in starting or driving	Key cannot be removed
LOCK	Use when locking the vehicle (the vehicle is powered off and the direction is locked)	Key can be removed

### **Warning**

- During the parking (including parking for a long time), the ignition switch must be in the "OFF" or "LOCK" position to ensure the safety of the vehicle and prevent the battery from "losing power".
- Do not push the motorcycle while the steering mechanism is locked, otherwise it will be out of balance.

## Start The Engine

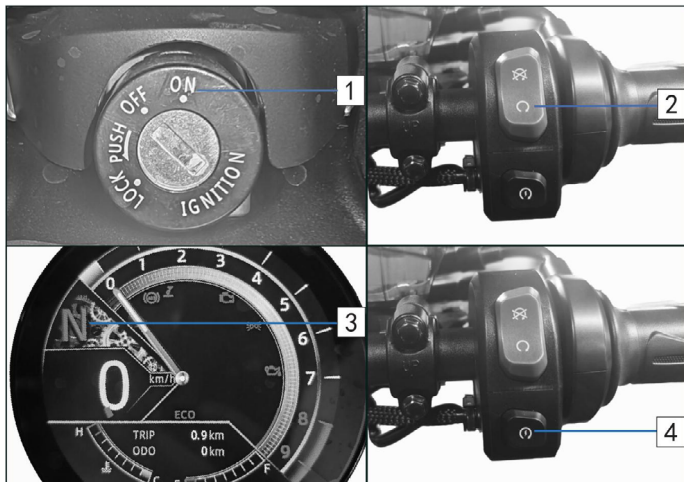

Regardless of whether the engine is cold or hot, please follow the instructions below to start the engine.

1. Turn the ignition switch to the "ON" position.
2. Make sure that the engine switch is in the “○” (ON) position.
3. Shift the gear to neutral, or pull the clutch lever and retract the side stand, then start the motorcycle with the transmission in gear.
4. With the throttle fully closed, press the starter button to start the motorcycle.

### **If the engine fails to start:**

If the engine does not start within 3 seconds, wait for 10 seconds before repeating step 4.

### Notes

- If the engine starts but idles unevenly, slightly increase the throttle.
- Prolonged high-speed idling and rotation can harm the engine and exhaust system.
- Sudden acceleration or prolonged idling at high speed for more than 5 minutes may cause the exhaust pipe to discolor.
- If the throttle is fully open, the engine will not start.

## Gear Shifting

Your motorcycle features 6 forward gears with a 1-down, 5-up shifting pattern.

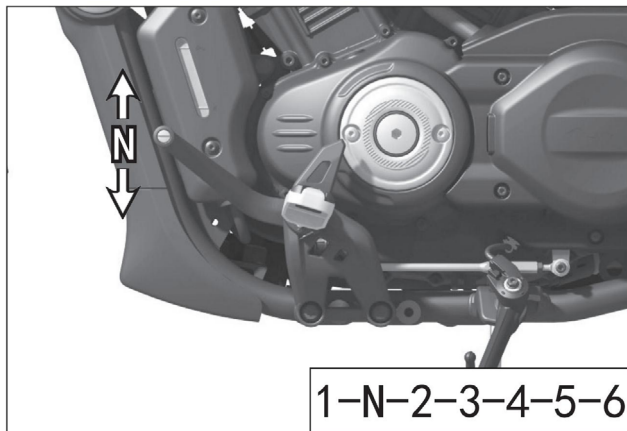

### Gear shifting method:

Warm up the engine to ensure smooth operation.

1. When the engine is idling, disengage the clutch and press the gear shift pedal downward to engage the low gear (1st gear).
2. Gradually increase the engine speed while slowly releasing the clutch lever, coordinating these two actions to ensure a smooth start.
3. When the motorcycle reaches a steady riding state, reduce the engine speed, disengage the clutch, and lift the gear shift pedal to engage the 2nd gear, and so on.

### Things to pay attention to while driving:

1. Avoid unnecessary engine idling, and do not allow the engine to idle at high speeds, as this can severely damage the components.
2. Driving with the clutch partially engaged will quickly wear out the clutch plates.
3. If you feel the engine lacks power while climbing a slope, promptly shift to a lower gear.
4. On steep slopes, curves, and situations that may cause loss of vehicle control, do not use the front brake alone or coast in neutral. Do not ride without holding the handlebars.
5. When stopping, reduce the throttle, disengage the clutch at the same time, and then apply the brakes

## Traction Control System (TCS)

The motorcycle is equipped with TCS (Traction Control System), which allows the motorcycle to achieve optimal traction during driving. It effectively suppresses the rear wheel slippage during starts, sudden acceleration, etc., on slippery surfaces (such as ice, snow, rain, muddy), thereby improving driving stability and safety.

You can turn the TCS function on or off through instrument settings. It is recommended to keep the TCS function on unless there are special circumstances. When TCS is turned off and the rear wheel loses grip, the system will not request torque reduction, which may cause the vehicle to yaw or crash. The rider should adjust their riding style accordingly.

On slippery surfaces, TCS will not operate due to the engine's inherent braking intervention. If you suddenly decelerate by releasing accelerator, it may cause uncontrollable rear wheel slippage. Do not suddenly close the accelerator, especially when riding on slippery surfaces.

TCS may not be able to handle rapid refueling operations on rough roads. When accelerating, please consider the road and weather conditions, as well as your skills and physical condition. If motorcycle is stuck in mud, snow, or sand, temporarily turning off the TCS can make it easier to get motorcycle out. Turning off the TCS helps maintain control and balance during off-road riding.

Always use the tire specifications, wheel speed sensors, and ring gears recommended by KOVEMOTO to ensure the TCS run properly.

When the TCS function is active, you may feel a weaker power output from the vehicle. This is normal and there is no need to worry or take any additional measures.

### Notes

- While riding, if TCS indicator comes on, it may indicate that the TCS function has malfunctioned. Please turn off the key switch, then turn it back on, and also turn on the ignition switch on the right handlebar. If the indicator still remains on, it indicates an abnormality in the TCS function. Please take the vehicle to an authorized KOVEMOTO motorcycle repair shop as soon as possible for troubleshooting.

## Refueling

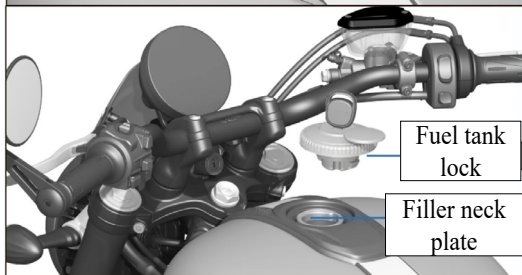
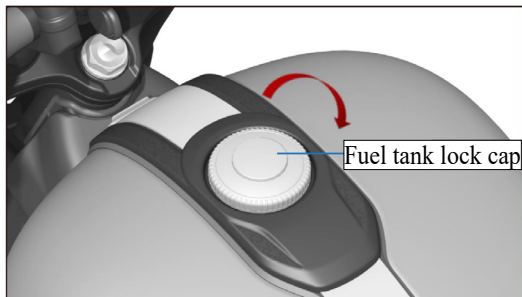

### Open the fuel tank lock:

Slide the fuel tank lock cover clockwise, insert the ignition key, turn it clockwise, and lift to remove the fuel tank lock.

### Close the fuel tank lock:

After the refueling, align the lock cylinder with the fuel filler neck and press down with moderate force. Once the locking mechanism engages, remove the key and close the fuel tank lock cover. Once the seat lock latch engages, remove the key and close the fuel tank cap.

### When refueling:

After stopping the vehicle using the side stand, open the fuel tank for refueling. Do not fill above the neck plate of the filler neck. The total fuel tank capacity is 20L (15.8L for the front tank and 4.2L for the rear tank). When the fuel level in the fuel tank is low, the fuel indicator light on the instrument panel will illuminate. At this point, the remaining fuel in the rear fuel tank can sustain approximately 50km of driving. Please refuel as soon as possible. After refueling, close and secure the fuel tank lock. The capacity of the fuel tank is 20 L. It is recommended to use 95# or above unleaded gasoline.

### Warning

- When refueling, always do so outdoors, ensure the engine is turned off, stay away from heat sources, sparks, or open flames, and immediately wipe up any spills.
- After refueling, it takes some time for the fuel to flow to the auxiliary fuel tank. Monitor the fuel level to check if the fuel level drops.

# Maintenance

**Please carefully read the “Maintenance” and “Maintenance Guidelines” sections before preparing for maintenance.**

Maintenance.....	30
Maintenance Interval Table.....	31
Critical Component Torque Periodic Inspection Checklist.....	32
Maintenance Guidelines.....	33
Replacement Parts.....	34
Removal and Installation of Body Components.....	41
Engine Oil.....	43
Coolant.....	45
Brake.....	47
Side Stand.....	49
Drive Belt.....	50
Clutch.....	52
Accelerator.....	53
Headlight.....	54

## Maintenance

### Importance of Maintenance

Always maintain your motorcycle in good condition, as it is essential for your safety, protecting your property, achieving optimal performance, preventing breakdowns, and reducing air pollution.

Maintenance is a crucial responsibility for motorcycle owners. Make sure to perform checks before each ride and conduct regular inspections according to the maintenance interval table.

#### **Please follow these guidelines during maintenance:**

- Extinguish the engine and remove the key.
- Park the motorcycle on a firm and level surface using the side stand, or support it with a maintenance stand.
- Wait for the engine, muffler, brakes, and other high-temperature components to cool down before starting operations; otherwise, it may cause burns.
- Start the engine under specified conditions and ensure it is in a well-ventilated environment.

#### **▲ Warning**

- Failure to perform regular maintenance before riding or to properly address faults may result in serious or fatal accidents.
- Please follow the inspection, maintenance recommendations, and maintenance interval table provided in the user manual.

## Maintenance Interval Table

The vehicle should be serviced within the specified time frame. To ensure safety, only authorized KOVEMOTO motorcycle service centers are qualified for the maintenance. The meanings of the symbols in the table are as follows:

I: Inspect, clean R: Replace A: Adjust L: Lubricate

Maintenance Item		Odometer					Cycle	Notes	
		1000Km	10000Km	20000Km	30000Km	40000Km	1 year		
★	Throttle control system	I	I	I	I	I	I	After the mileage reaches 40,000 km, maintenance should be repeated at each maintenance interval starting from 10,000 km. ★ This item should be serviced by personnel from an authorized KOVEMOTO motorcycle service center. If the user has specialized tools, repair accessories, and repair skills, they can also perform the maintenance themselves. Repair instructions can be found in this Instruction Manual. ★ ★ To ensure safety, this project can only be serviced by authorized maintenance personnel from an authorized KOVEMOTO motorcycle service center. Notes: When riding in dusty or heavily polluted areas, the air filter element should be cleaned or replaced more frequently to reduce maintenance intervals. When riding under harsh operating conditions, the engine oil and oil filter replacement interval should be shortened; it is recommended to replace the engine oil if the vehicle has been parked for more than 6 months. Brake pad replacement can only be performed by personnel at an authorized KOVEMOTO motorcycle service center. When the tire wears to the △ TWI mark on the sidewall or the wear limit indicator at the center of tire, it must be replaced by personnel from an authorized KOVEMOTO motorcycle service center.	
★	Air filter element		R	R	R	R	R		Note 1
★★	Valve clearance			I/A		I/A	I		
★	Engine oil	Replace every 5000Km after the first service at 1000Km					R		Note 2
★	Oil filter element	Replace the oil at the same time					R		
	Drive belt	Clean and adjust the belt tension initially at 3,000 km, then every 10,000 km thereafter.					I/A		
	Brake pad wear	I	I	I	I	I	I		Note 3
★	Brake system	I	I	I	I	I	I		
★	Clutch	I	I	I	I	I	I		
★	Fasteners	I	I	I	I	I	I		
★★	Steering bearing	I	I	I&L	I	I&L	I&L		
★★	Tire		I	I	I	I	I		Note 4
★★	Front and rear wheel bearings		I	I	I	I	I		
	Battery	I	I	I	I	I	I		
★★	Fuel system fuel line		I	I	I	I	I		
★★	Fuel filter		R	R	R	R	R		
★★	Spark plug		I	I/R	I	I&R	I&R		
★★	Plain fork bearing		I&L	I&L	I&L	I&L	I&L		
★★	Brake fluid		I	I	I	R	Replace every two years		
	Coolant		I	I	I	R	Replace every two years		

## Critical Component Torque Periodic Inspection Checklist

SN	Name of Fastening Location	Recommended inspection interval
1	Front and rear wheel axle tightening	Torque inspection is required during each maintenance cycle.
2	Upper and lower triple clamps tightening to secure the front shock absorber.	
3	Upper triple clamp and steering stem tightening	
4	Steering stem 4-slot nut tightening	
5	Handlebar lower clamp tightening	
6	Engine small pulley installation tightening	
7	Engine mounting fastening	
8	Rear shock absorber fastening	
9	Front and rear footpeg bracket bolt fastening	
10	Muffler to engine	
11	Front and rear brake caliper tightening	
12	Rear brake pump tightening	
13	Shift lever and adjustment rod end bearing tightening	
14	Brake pedal and adjusting lever end bearing tightening	
15	Entire brake line tightening	
16	Fuel injector tightening	
17	Fuel pump tightening	
18	Front and rear brake discs tightening	During each maintenance cycle inspection or replacement, perform maintenance according to the specified torque and sealing method.
19	ABS ring gear	
Note: For torque cycle inspection items not specified in this Instruction Manual, the torque standards shall be followed as per our company's "Maintenance Manual".		

## Maintenance Guidelines

To ensure safety, you are responsible for performing a pre-ride inspection and making sure that any issues identified have been resolved. Pre-ride inspection is essential.

Inspection Items	Inspection Details
Handlebar	Smooth and flexible rotation, free from play or looseness
Brake system	Check its operating condition, and inspect the front and rear brake fluid levels and brake pad wear
Fuel level	Sufficient fuel for the planned journey (refuel if necessary)
Accelerator	Check if it can open smoothly and close completely in all steering positions.
Clutch	Check its operating condition and adjust the free stroke if necessary.
Wheels/tires	Check its usage status and tire pressure, and inflate if necessary
Drive belt	Inspect its usage condition and tension, and adjust and lubricate if necessary
Lighting, horn	Check the lighting system and horn to ensure they are functioning correctly
Engine oil level	Add engine oil as needed and check for leaks
Instruction indicators	Check if all indicators on the instrument panel are functioning properly

## Replacement Parts

### Battery

Inspect and replace the battery.

1. Before installing the battery, if the electrodes are found to be dirty, clean them thoroughly before installation; otherwise, poor contact may lead to malfunction.
2. If during use, the battery exhibits abnormal phenomena such as deformation, overheating, or smoking, stop using it immediately and have it inspected by an authorized KOVEMOTO motorcycle service center.
3. If the battery is stored in a high-temperature or humid environment for an extended period, it may malfunction or experience a shortened lifespan. Before reuse, ensure the battery's appearance and functionality are normal.
4. If the vehicle fails to start, check whether the battery is functioning properly. If the battery is damaged, replace it immediately.
5. When installing the battery, ensure the battery terminal bolts are securely tightened.

**If the battery is not used for an extended period, please note the following:**

- To prevent over-discharge, the battery should be charged every two months.
- When the battery is not in use, it should be stored in a cool, dry environment, and the positive and negative terminals should be protected from short-circuiting.

#### Notes

- Improper handling of batteries may harm the environment and human health. Please dispose of used batteries in accordance with local environmental regulations.
- The addition of electrical appliances may cause battery drain and even electrical system malfunction.

## Fuse

Fuses protect your motorcycle's electrical circuits. If any electrical components of your motorcycle stop functioning, inspect and replace the blown fuse.

### ■ Inspect and replace the fuses

Turn the ignition switch to the "OFF" position, then remove and inspect the fuse. If the fuse is blown, replace it with a fuse of the same specification. Refer to the "Technical Parameters" section for the fuse Parameters.

If the fuse blows frequently, there may be a hidden issue with the electrical system. Please have it inspected by an authorized KOVEMOTO motorcycle service center.

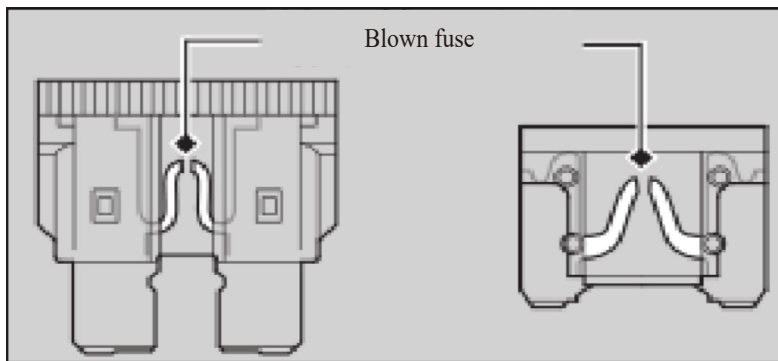

### Notes

- Fuses must be replaced with ones of the same rating. Using a fuse with a higher rating increases the risk of damaging the electrical system and may pose a fire hazard.
- Installing non-KOVEMOTO electrical accessories can overload the electrical system, lead to battery discharge, and even damage the system.

## Engine Oil

Engine oil consumption and degradation vary depending on riding conditions and usage duration. The higher the engine speed, the faster the oil consumption rate. When operating at high speeds or high RPM for extended periods, shorten the oil change interval. Regularly check the engine oil level and add the recommended engine oil if necessary.

When used in extreme temperatures, oil degrades more rapidly. Dirty or aged oil should be replaced promptly.

### Choosing Engine Oil

The initial engine oil should be SN\_10W/40, and the maintenance engine oil should be API-classified SN grade or higher.

#### Notes

- Brake fluid can damage plastic and painted surfaces. If spilled, wipe it off immediately and clean thoroughly.
- Recommended brake fluid: DOT4 or equivalent.
- Use coolant specifically designed for non-aluminum engines, as ordinary tap water or mineral water can cause corrosion.

## Brake Fluid

Do not add or replace brake fluid except in an emergency.

Only use brake fluid that has been freshly taken from a sealed container. If you have added brake fluid, please have the brake system inspected by an authorized KOVEMOTO motorcycle service center as soon as possible.

## Coolant

Only use the original undiluted KOVEMOTO motorcycle pre-mixed coolant, which offers superior protection against corrosion and overheating. Regularly check the coolant level and promptly add more if it falls below the minimum mark. The coolant has a freezing point of -40°C and a boiling point of 110°C.

## Drive Belt

### Model and Specifications

1760-11M-29 (DAYCO)

Belt tooth count: 162T, pitch: 11mm

### Cleaning and Lubricating

The drive belt does not require oiling or lubrication.

Please keep the belt and pulley clean. If the belt has dust, mud, or other stains, rinse it with clear water.

Before cleaning, carefully check the belt for wear, cracks, or other issues. If any serious problems are found, replace the belt promptly.

### Abnormal wear check

The drive belt must be regularly inspected and lubricated. If frequently ridden on poor road surfaces, at high speeds, or with repeated rapid acceleration, the belt should be checked more often. If the drive belt is not running smoothly or making abnormal knocking, please have it inspected by a KOVEMOTO Motorcycle Authorized Repair Shop.

Also inspect the small pulley and big pulley. If either shows wear or damaged teeth, have them replaced by a KOVEMOTO motorcycle authorized repair shop.

### Warning

- To ensure the service life and strength of the belt, please use the original manufacturer's specification for the drive belt.

## Tire (Inspection/Replacement)

### Tire specifications

Front tire: 120/70 R18

Rear tire: 160/60 R16

### Abnormal wear check

Inspect the tire's contact surface for any signs of abnormal wear.

### Inspect the tread depth

Check the tread wear indicator marks; if the wear reaches the indicators, replace the tire immediately.

### Check the tire pressure

When you feel the tire pressure is low, measure it with a pressure gauge. Check the tire pressure when the tires are cool, and do this at least once a month. Ensure the valve core cap is securely tightened; replace it with a new one if necessary. The standard tire pressure is: Front tire: 230 kPa; Rear tire: 250 kPa.

### Check the damage

Inspect the tires for cuts, cracks, exposed fabric, tire cords, nails, or other foreign matters embedded in the sidewall tread, and also check for any abnormal bulges or swelling on the tire sidewall.

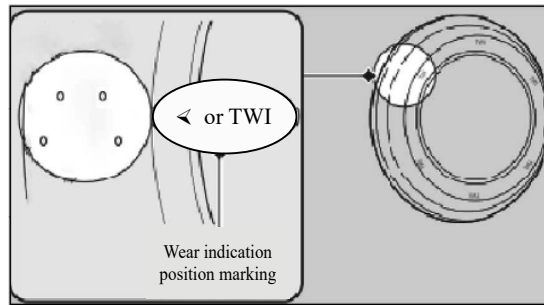

**Whenever replacing tires, follow these guidelines:**

- Use the recommended tires or equivalent products with the same size, structure, speed rating, and load capacity.
- After installing the tires, use the original KOVEMOTO motorcycle wheel balancer or equivalent equipment to balance and align the wheels.
- This motorcycle rim is designed for use with inner tubeless tires. Do not install Inner tube in tire yourself. If Inner tube is installed, it will rub against rim during rapid acceleration or braking, and the excessive heat will cause Inner tube to burst.

**⚠ Warning**

- Using excessively worn or improperly inflated tires can lead to accidents, resulting in serious injuries or fatalities. Please follow the relevant tire inflation and maintenance guidelines provided in the Instruction Manual.
- Installing unsuitable tires can impair handling and stability, potentially causing accidents and even endangering lives.
- Always use the tire size and type recommended in this Instruction Manual.

## Air Filter

This motorcycle is equipped with a paper air filter element. Do not perform maintenance yourself. It should be cleaned or replaced by an authorized KOVEMOTO motorcycle service center.

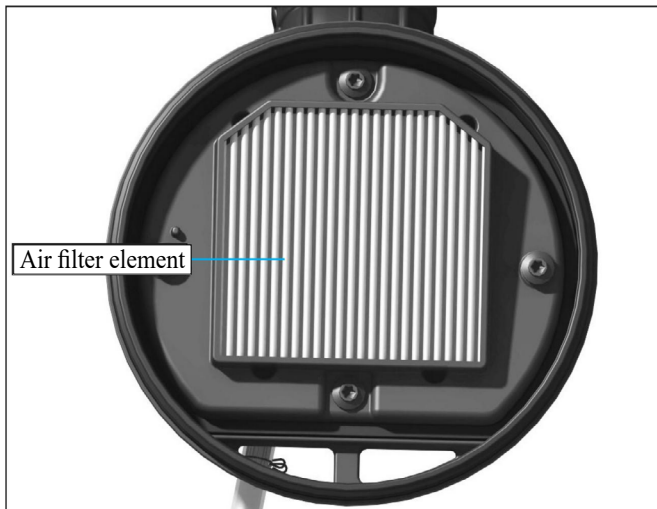

## Tools

The onboard tools are embedded under seat cushion towards the back.

You can use the onboard tools to conduct some simple repairs, fine-tune, and replacement of parts.

- Double-ended internal torx wrench T25×T30
- Double-ended internal torx wrench T40×T40

## Removal and Installation of Body Components

### Battery

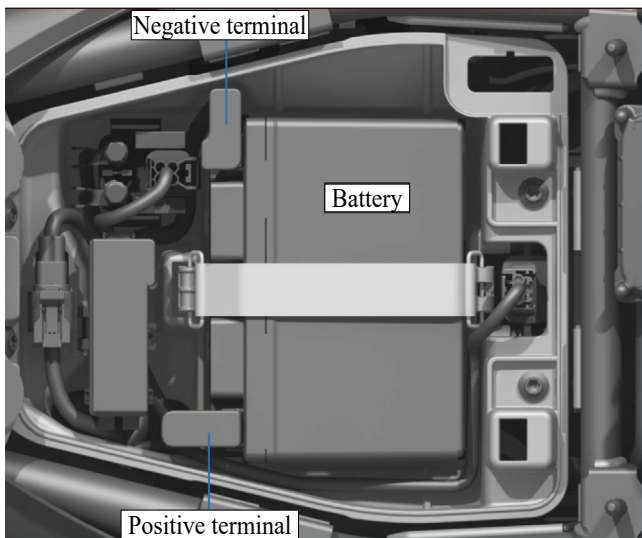

#### ■ Disassembly

Make sure the ignition switch is turned to the "OFF" position.

1. Remove the seat cushion.
2. Release the rubber strap from the back.
3. Disconnect the negative (-) terminal of the battery.
4. Disconnect the positive (+) terminal of the battery.
5. Remove the battery, being careful not to leave the bolts and nuts.

#### ■ Installation

Install all parts in the reverse order of removal, ensuring to connect the positive terminal (+) first and the negative terminal (-) last; ensure that the bolts and nuts are tightened.

## Battery

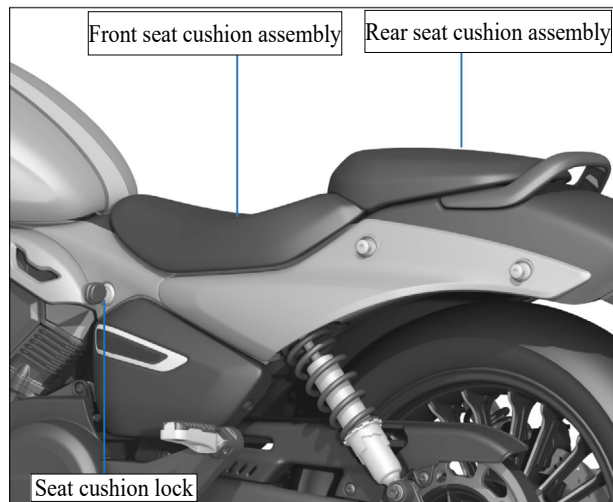

### Disassembly

1. Insert the ignition key into the seat cushion lock, rotate the key clockwise, and at the same time, apply slight force to the front end of the rear seat cushion assembly. Then, lift the rear end upwards to disengage it from the lock, and finally, apply slight force backwards to remove the rear seat cushion assembly.
2. Lift the front seat cushion assembly upward to remove it.

### Installation

1. Insert the front limit hanging point of the front seat cushion assembly into the body groove, and the rear limit bore shall align with the pin.
2. The rear limit hanging point of the rear seat cushion assembly must be engaged with the seat cushion mounting bracket, while the front end should align with the seat cushion locking pin and bore. Ensure the locking pin is fully inserted into the bore and automatically secured by the locking latch. Gently pull upward to confirm the seat cushion is securely locked in position.
3. When the seat cushion is closed, the seat cushion will automatically lock.

### Notes

- Ensure the seat pin is securely inserted into the frame slot; otherwise, the seat may not support your weight and could be damaged.

## Engine Oil

### Inspect and Top Up Engine Oil

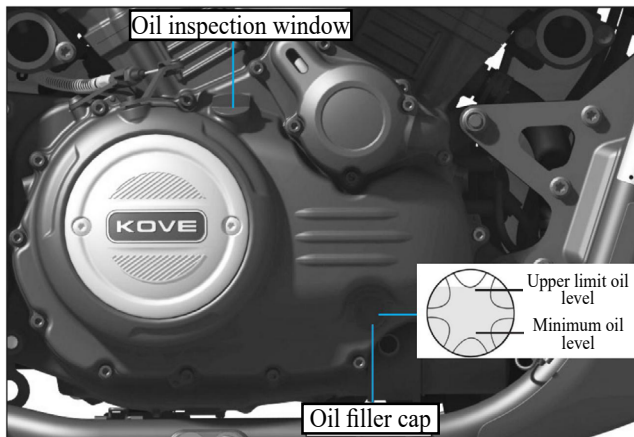

#### Notes

- Long-term skin contact with oil shall be avoided. Wash thoroughly after contact with oil.
- Overfilling or underfilling the oil will damage the engine. Do not mix oils of different brands and grades, as this will affect lubrication and clutch operation.
- The used engine oil and container are harmful to health and the environment. They cannot be disposed of as household waste and should be handled in accordance with local environmental regulations.

#### Check the engine oil

1. Let the engine idle for 3 - 5 minutes, turn the ignition switch to the “OFF” position, and then wait for 2 - 3 minutes.
2. Place the motorcycle vertically upward on a stable and flat ground, check whether the oil level is between the upper and lower limit mark from the engine oil inspection window.

#### Add the engine oil

When the engine oil level is below or close to the lower limit mark, add the recommended engine oil.

1. Remove the engine oil filler cap, add the recommended oil to the upper mark of the oil level. Do not exceed the upper limit mark, and ensure that no foreign matters enter the engine oil filler. If there is any spillage, wipe it off immediately.
2. Reinstall and tighten the engine oil filler cap.

## Replace The Engine Oil and The Oil Filter

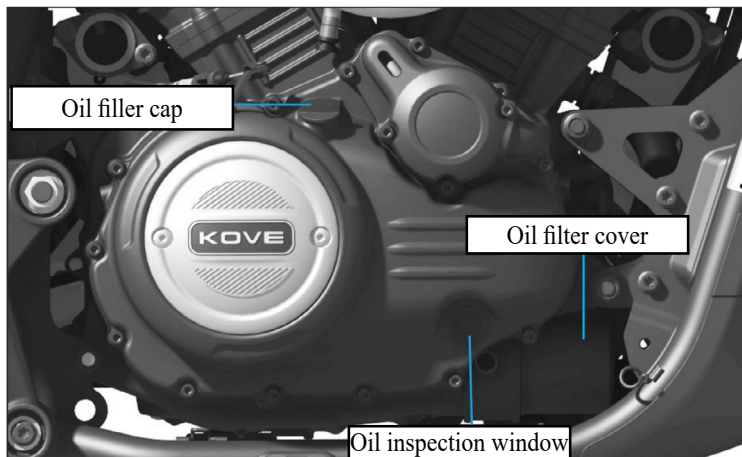

### Replace the engine oil and the oil filter

Special tools are required to replace the engine oil and the oil filter. We recommend that the inspection and maintenance be completed by an authorized KOVEMOTO motorcycle service center. Please refer to the "Maintenance Interval Table" for the maintenance interval of engine oil and secondary oil filter.

1. If the engine is cold, please idle for 3-5 minutes, turn the ignition switch to the "OFF" position, and then wait for another 2-3 minutes.
2. Park the motorcycle on a stable, level surface and place an oil drain pan beneath the drain bolt.

3. Remove the filler cap, oil drain bolt, and sealing washer, then drain the engine oil, ensuring the old gasket is not stuck to the engine.
4. Use filter wrench to remove the filter, drain the remaining engine oil, and ensure that the old rubber ring is not stuck to the engine.
5. Apply a thin layer of engine oil to the rubber seal on the new oil filter.
6. Install a new engine oil filter and tighten it (torque: 12 N·m).
7. Install a new sealing washer on the oil drain bolt and tighten the oil drain bolt (torque: 28 N·m).
8. Add the recommended original engine oil into the crankshaft tank, and tighten the oil filler cap after filling.
9. Check the engine oil for leakage.

**When replacing the filter element, the required oil level: 2.7 L**

**When the filter element is not replaced, the required oil level: 2.5 L**

**When reassembling after disassembling the engine, the required oil level: 2.9 L**

### Notes

- Using the wrong engine oil and oil filter can seriously damage the engine.
- Dispose of the engine oil and oil filter at the appropriate recycling center.
- Use the specified KOVEMOTO original engine oil and oil filter.

## Coolant

### Inspect The Coolant Level

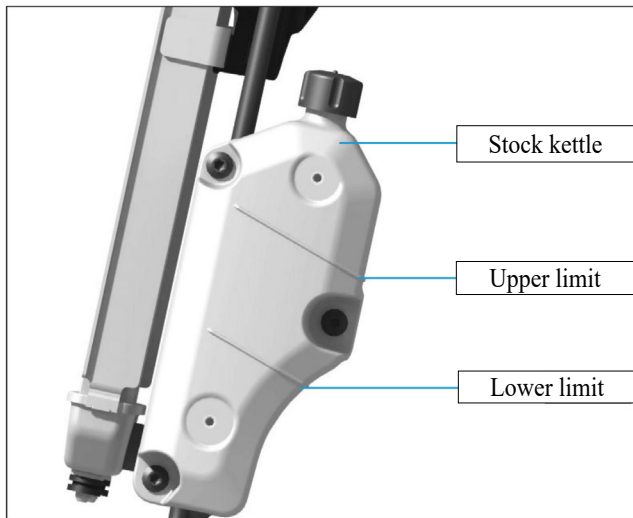

Check the coolant level in the reservoir when the engine is cool.

1. Park the motorcycle on a firm and flat level.
2. Keep the motorcycle upright.
3. Check if the coolant level in the water reservoir is between the upper limit and lower limit marks.
4. If the coolant level drops significantly or the reservoir is empty, there may be a serious leak. Please have it inspected by an authorized KOVEMOTO motorcycle service center.

## Add Coolant

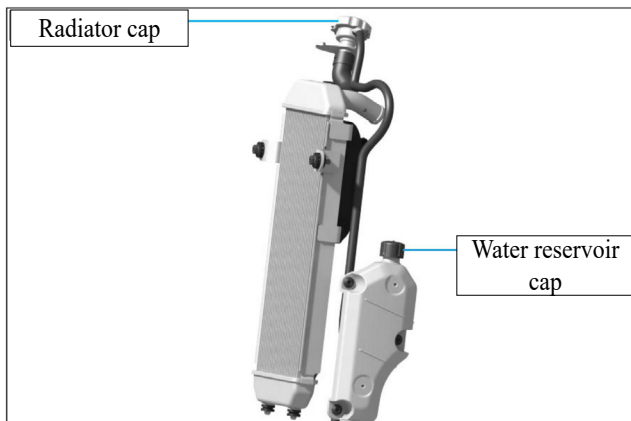

If the coolant is below lower limit, add the recommended coolant until the level reaches upper limit.

When adding the coolant, open the radiator cap to release pressure when the engine is cool, then open the water reservoir at the other end to add coolant. Ensure no foreign matter enter the cap opening and do not exceed upper limit during the process.

After completing the addition, reinstall the relevant caps.

## Replace The Coolant

Unless you possess the appropriate tools and qualified mechanical skills, please entrust the coolant replacement to the authorized KOVEMOTO motorcycle service center.

**Coolant capacity:**

**Radiator (including all water channels): 1.4L**

**Water reservoir (to upper limit level): 0.24L**

### **Warning**

- Do not remove the radiator cap while the engine is still hot, as this may cause the coolant to spray out and potentially cause burns.

## Brake

### Inspect The Brake Fluid

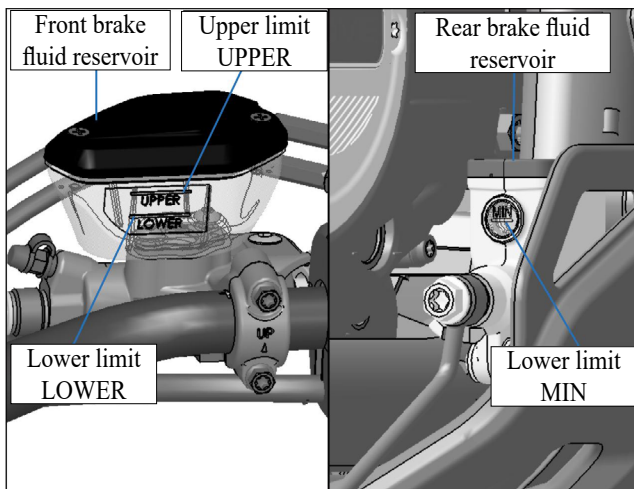

1. Place the motorcycle vertically on a firm and flat ground.
2. Check if the brake fluid reservoirs are horizontal.
3. Check if the brake fluid is visible in the inspection window. If the brake fluid level is below the lower limit of the inspection window, add it immediately.

If the brake fluid level in the oil cup is lower than the lower limit (LOWER) level mark or the free stroke of the brake rod and pedal is out of limit, users must check whether the brake pad is worn. If the brake pad is not worn, there may be leakage. Please have it repaired by an authorized KOVEMOTO motorcycle service center.

## Check The Brake Pads

Inspect the condition of the brake pad wear indicator. If the brake pad wears down to the indicator mark, it must be replaced.

**Front** Inspect the brake pad from beneath the brake caliper.  
Brake pad lining thickness: 3.5mm (indicator mark indicates the wear limit)

**Rear** Inspect the brake pad from the right rear of the brake caliper.  
Brake pad lining thickness: 4.0mm (indicator mark indicates the wear limit)

If necessary, have the brake pads replaced by an authorized KOVEMOTO motorcycle service center (when the wear limit is reached, both the left and right brake pads must be replaced simultaneously).

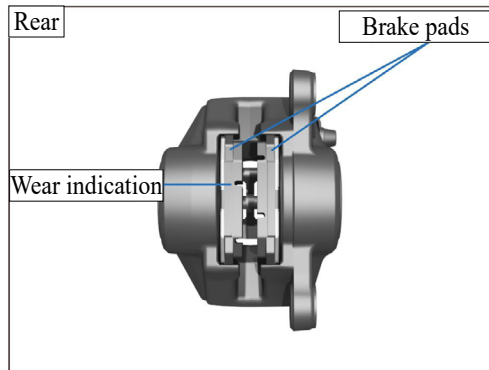
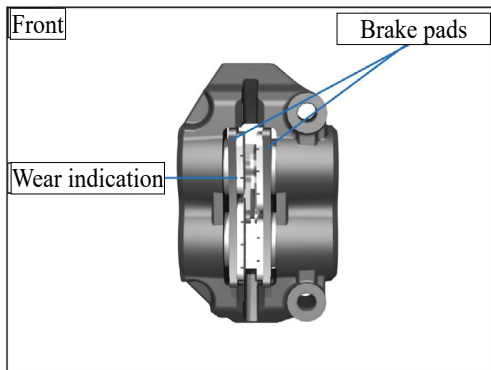

## Brake

### Inspect The Brake Fluid

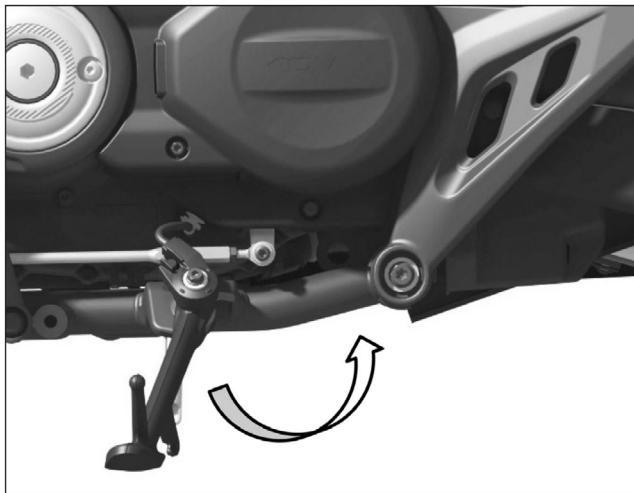

1. Check if the side stand operates smoothly. If the side stand is stuck or makes a squeaking noise, clean the pivot area and lubricate with clean grease.
2. Check the spring damages or inelasticity.

## Drive Belt

### Check The Drive Belt Tension

Remove the lower cover of the drive belt, lift the middle section of the belt to suspend it, and measure the vibration frequency to determine if the belt tension is correct. Please check the belt tension in a timely manner according to the maintenance interval table. The belt tension check must be performed at a KOVEMOTO motorcycle authorized repair shop.

Measuring tool: Belt tension gauge  
Belt vibration frequency: 50–56 Hz.

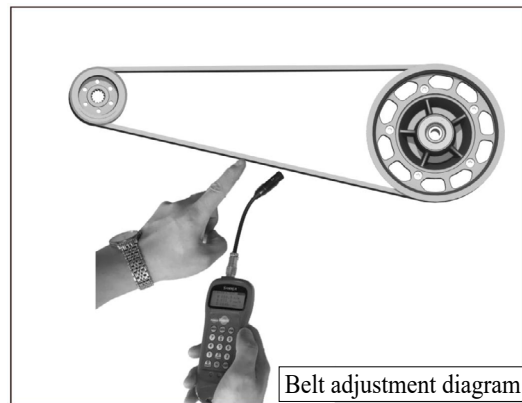

#### Notes

- An excessively low belt tension frequency will affect the normal operation of the vehicle; an excessively high frequency may cause abnormal knocking and reduce the service life of the drive belt.

## Adjust The Drive Belt Tension

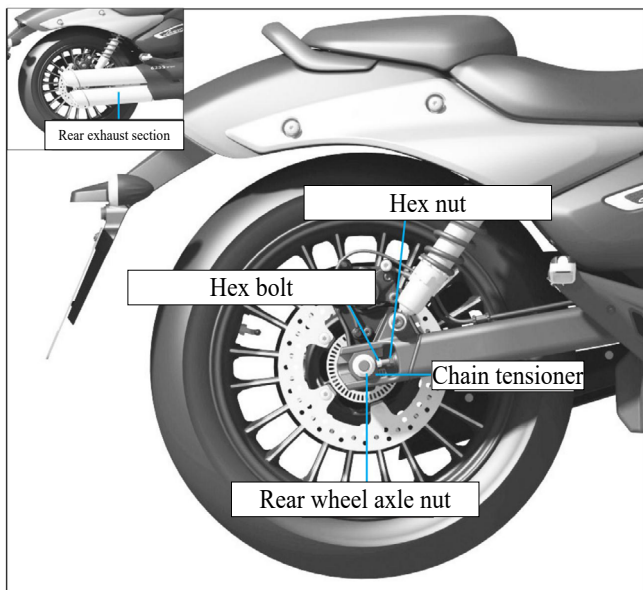

When adjusting the drive belt tension:

1. Put the transmission into neutral and turn off the engine.
2. Place the motorcycle vertically on a stable and flat surface, and support the vehicle with the side stand.
3. Remove the rear exhaust section.
4. Loosen the rear wheel shaft and loosen the hex nut on both sides of the swingarm.
5. Adjust the hex bolts: loosen the belt by turning clockwise and tighten it by turning counterclockwise.
6. Adjust the belt tension by rotating the hex bolts on both sides until the belt adjusters on both sides align with the same scale line. Manually move the drive belt to the position indicated in the diagram (see the diagram for details) to vibrate the belt and measure the vibration frequency.
7. Adjust the frequency to 50–56 Hz.
8. Tighten the hex nut and tighten the rear wheel shaft nut (Torque: 108N·m).

### Notes

- When measuring the belt tension frequency, the wheel shaft nut must be tightened.

## Accelerator

Clutch lever free stroke: 10-20mm

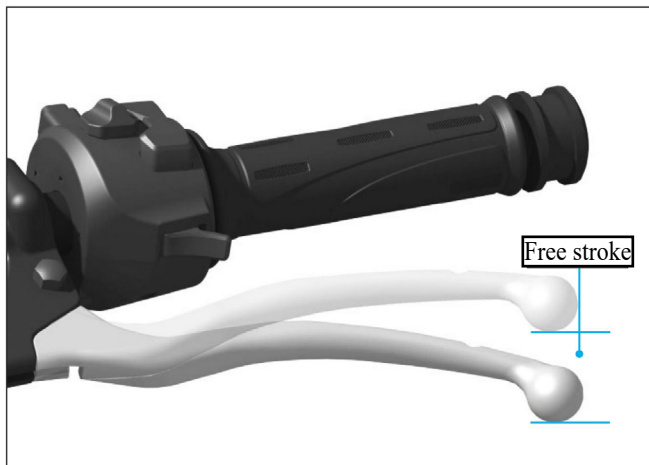

Inspect the clutch cable for any bends or signs of damage. If necessary, have it replaced by an authorized KOVEMOTO motorcycle service center.

Lubricate the clutch cable with a dedicated cable lubricant to prevent premature wear and corrosion.

### Notes

- Incorrect adjustment of the free stroke can lead to premature wear of the clutch.

## Accelerator

### Inspect The Throttle

With the engine off, check if the throttle can smoothly transition from fully closed to fully open in all handlebar positions and if the free play is correct.

If the throttle operation is not smooth, it automatically closes, or the cable is damaged, have it inspected by an authorized KOVEMOTO motorcycle service center.

Free play of the throttle handle flange: 2-6mm

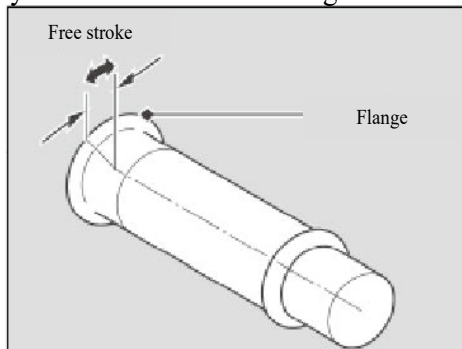

#### Notes

- Do not turn the adjuster beyond its natural limit.

### Adjust The Brake Handle

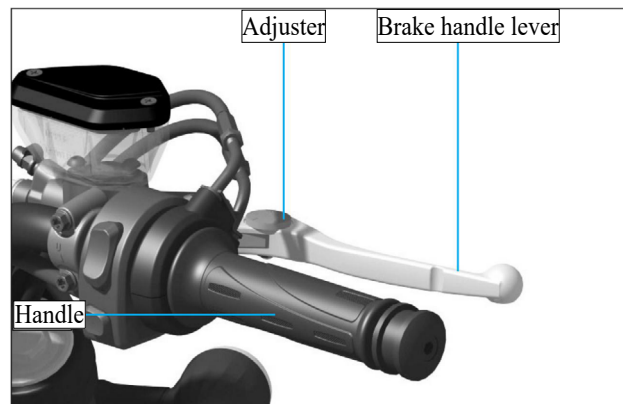

You can adjust the distance between the top of the brake handle and the handlebar grip.

#### Adjustment method

Push the hand brake lever outward to the desired position while rotating the adjuster until the numbers align with the markings. After adjustment, check whether the brake handle works correctly before riding.

## Headlight

### Adjust the headlight beam

You can adjust the angle of the headlight beam by rotating the adjusting screw, and the clockwise rotation is the overall decline of the headlight beam; The counterclockwise rotation is the overall rise of the headlight beam. Please comply with local laws and regulations.

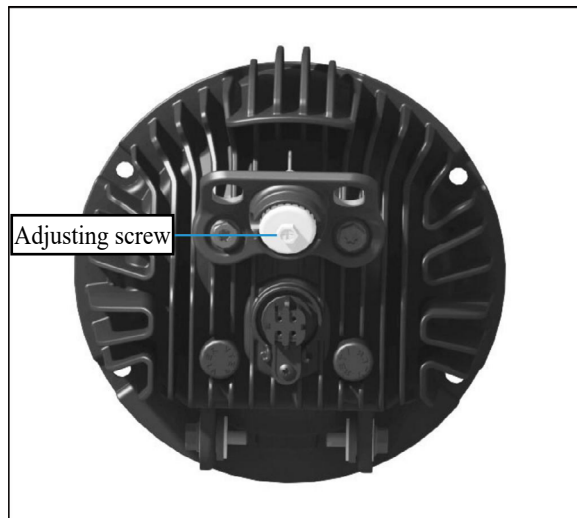

# Fault Handling

Please carefully read the “Maintenance” and “Maintenance Guidelines” sections before maintenance.

The Engine Fails To Start.....	56
The Warning Indicator is On or Flashing.....	57
Puncture .....	59
Removing The Wheel .....	60
Electrical Malfunction .....	64

## The Engine Fails To Start

### The Starter Motor Runs, But The Engine Fails To Start

#### Inspect the following items:

- Verify that the correct engine start sequence is being conducted.
- Check if there is fuel in the tank.
- Check whether the battery voltage is too low.
- Check if side stand retracted.

### The Starter Motor Is Not Functioning

#### Inspect the following items:

- Verify that the engine start sequence is correct.
- Ensure that the engine OFF switch is in the operating position.
- Check whether the battery voltage is too low, the fuse is blown, or the battery connection is loose. If the problem persists, please have it inspected by an authorized KOVEMOTO motorcycle service center.

#### Notes

- Continuing to ride with an overheated engine can cause serious engine damage.
- Running the engine at high speed in neutral for an extended period may trigger a high coolant temperature alarm.

### Overheating (Water Temperature Warning Indicator On)

If the engine gets overheating caused by the water temperature warning indicator on and slow acceleration, push motorcycle to a safe roadside and take the following measures:

1. Extinguish the engine with the ignition switch, then rotate it to the "ON" position.
2. Check if radiator fan runs normally, then rotate the ignition switch to the "OFF" position.

**If the fan does not run:** Do not start the engine, and have your motorcycle checked and repaired by a KOVEMOTO motorcycle authorized repair shop.

**If the fan runs:** Keep the ignition switch in the "OFF" position and wait for the engine to cool down.

3. After the engine has cooled, check the radiator for leaks.

**If there is a leak:** Do not start the engine, and have your motorcycle by a KOVEMOTO motorcycle authorized repair shop.

4. Check the coolant in the water reservoir and add if necessary.

5. If all checks from items 1 to 4 are normal, you may continue riding, but please keep a close attention on the indicators.

## The Warning Indicator is On or Flashing

### Oil Pressure Indicator

If the oil pressure indicator is on, push the motorcycle to a safe side of the road and turn off the engine, and take the following measures:

1. Check the engine oil level and add oil if necessary.
2. You can continue to ride only after the indicator goes out.
3. When the oil is at or near the lower limit, a rapid increase in speed may cause the indicator light to illuminate.
4. If the oil level is at a normal level and the indicator is still on, please turn off the engine and contact an authorized KOVEMOTO motorcycle service center.
5. If the engine oil drops quickly, your motorcycle may leak oil or have other serious problems. Please send it to an authorized KOVEMOTO motorcycle service center for inspection or maintenance.

#### Notes

- Continued driving at low oil pressure can seriously damage the engine.

### Electronic Injection Malfunction Indicator Light

If the EFI fault indicator comes on while riding, there may be a serious problem with your electronic fuel injection system. Please slow down and have it inspected by an authorized KOVEMOTO motorcycle service center as soon as possible.

### Turn Indicator Light

If the turn signal flashes abnormally or at an increased frequency during use, promptly check for any faults to prevent incorrect signals from causing safety hazards. Besides, have it inspected and repaired at an authorized KOVEMOTO motorcycle service center as soon as possible.

## ABS Fault Indicator (Anti-Lock Braking System)

If the ABS fault indicator shows any of the following conditions, it indicates a fault in your ABS, and emergency braking will not provide anti-lock function. Please have it inspected by an authorized KOVEMOTO motorcycle service center as soon as possible.

- During riding, the ABS fault indicator stays on or flashes .
- When Ignition is rotated from "OFF" position to the "ON" position, the indicator does not come on.
- When the speed is above 5 km/h, the indicator does not extinguish.

The ABS fault indicator may flash or stay on under the following conditions:

- Rotating the front wheel alone.
- Rotating the rear wheel alone.
- The rear wheel gets slippery.
- Riding on special road surfaces.

You can rotate the ignition switch to the "OFF" position and then to the "ON" position to power on the system.

## Puncture

Repairing a flat tire or removing a wheel requires special tools and professional skills. We recommend leaving such maintenance tasks to a KOVEMOTO motorcycle authorized repair shop. If you have performed overtightened tire repair, be sure to have tire inspected or tire replaced by an authorized KOVEMOTO motorcycle service center.

### **Perform emergency repairs using a tire repair kit**

If your tire has a minor puncture, you can use an inner tubeless tire repair kit to perform emergency repairs.

Follow the instructions provided by the tire emergency repair kit. Riding a motorcycle with a temporarily repaired tire is very dangerous, and the speed should not exceed 50 kilometers per hour. Please have the tire replaced as soon as possible at an authorized KOVEMOTO motorcycle repair shop.

#### **⚠ Warning**

- Riding a motorcycle with a temporarily patched tire is extremely hazardous. If the patch fails, it could lead to an accident, causing severe injuries or fatalities.
- If you must ride a motorcycle with a temporarily repaired tire, ride cautiously and slowly, not exceeding 50 km/h, until the tire is replaced.

## Removing The Wheel

### Front Wheel

If you need to remove the wheel to repair a punctured tire, follow the steps below. Be careful not to damage the wheel speed sensor and ABS ring gear when removing and installing the wheel.

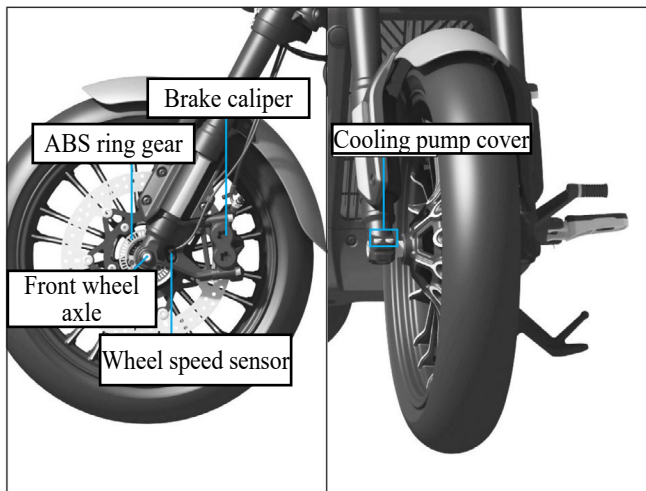

#### Disassemble:

1. Securely support your motorcycle with a maintenance bracket or a crane and lift the front wheels off the ground.
2. Remove the front fender.
3. Remove the left brake caliper.
  - Support the brake caliper assembly well and do not hang it on the brake hose. Do not twist the brake hose.
  - Avoid getting lubricating oil, engine oil or dirt on the brake disc or brake pad.
  - When the brake caliper is removed, do not pull the brake handle.
  - Be careful to prevent the brake caliper from scratching the wheel during removal.
4. Loosen the wheel shaft locking bolt and front wheel axle.
5. Remove the front wheel axle and front wheel.

## Installation

1. Clean the front axle and the locking bores of the front shock absorber. Apply grease evenly around the groove between the main and auxiliary lips of the front hub oil seal.
  2. Place the front wheel between the front shock absorber, insert bushing (left) into the left mounting bore of the front wheel.
  3. Insert the front wheel axle through the front wheel from right to left and tighten it (front wheel axle M16, torque  $70\pm 2$  N·m).
  4. Place the front wheel on the ground, then shake the front fork up and down a few times to ensure it returns to the correct position.
  5. Install the brake caliper, squeeze the hand brake lever, and tighten the bolts (torque: 45 N·m). Prevent the brake caliper from scratching the wheel during installation. Please use a new assembly bolt when installing the brake caliper.
  6. Install the two right-side locking bolts (front wheel axle locking bolt M8, torque: 22 N·m) and the front fender.
  7. Lift the front wheel off the ground, and after releasing the brake lever, check if the wheel turns smoothly.
- If a torque wrench was not used during the installation process, please take it to an authorized KOVEMOTO motorcycle service center as soon as possible. Improper installation may result in reduced braking performance.

## Notes

- When reinstalling the wheel or caliper, carefully position the brake disc between the brake pads to prevent scratching them.
- When installing the front wheel, first tighten the front axle, then secure the lock bolt on the right side of the front axle. The order of these steps cannot be reversed.

## Rear Wheel

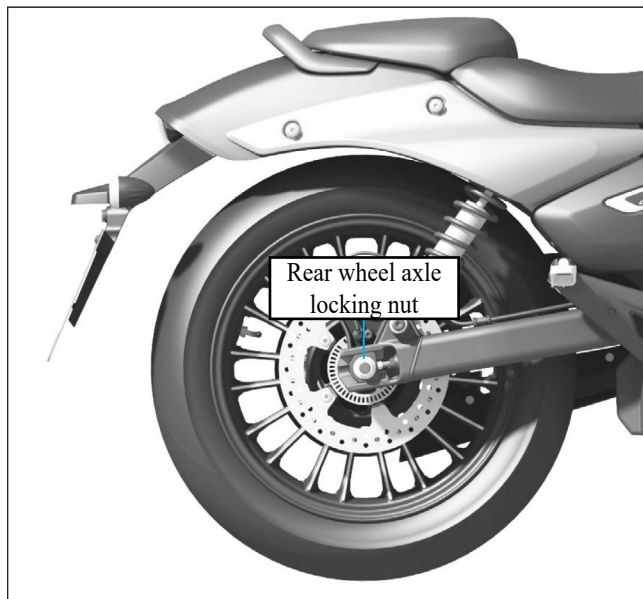

### Disassembly

1. Park the motorcycle on a firm and flat level.
2. Firmly support your motorcycle with side stands or service bracket and lift the rear wheel off the ground.
3. Remove the rear wheel axle locking nut and washer.
4. Hold the rear wheel to remove the rear wheel axle and the left and right rear wheel bushings.
5. Withdraw the chain adjusting blocks on both the left and right sides so that the wheel can move forward continuously.
6. Push the rear wheel forward to disengage the drive belt from the large pulley;
7. Remove the rear wheel.

## Installation

1. Install the rear wheel in the reverse order of removal to prevent the brake caliper pin from scratching the wheel during installation.
2. Apply the grease evenly on bearing.
3. Align the rear wheel bore with the rear swingarm bore. First, install the rear wheel bushing (the bushing should be lubricated with grease), then insert the rear wheel axle from left to right into the wheel assembly bore.
4. Reinstall the drive belt onto the large pulley and adjust its tension.
5. Tighten the rear wheel axle nut (Torque: 108 N·m).
6. Check if the wheel rotates smooth.

If a torque wrench was not used during the installation process, please take it to an authorized KOVEMOTO motorcycle service center as soon as possible. Improper installation may result in reduced braking performance.

### Notes

- When reinstalling the wheel or caliper, carefully position the brake disc between the brake pads to avoid scratches.

## Electrical Malfunction

### Fuse Blown

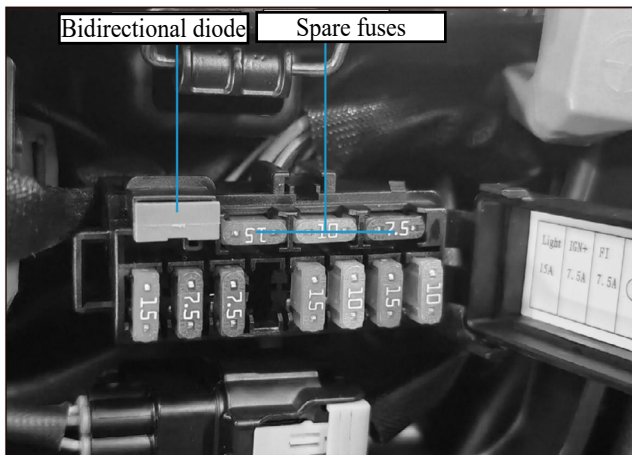

#### Replace the fuse wire.

1. Remove the seat cushion.
2. Open the fuse box, remove the fuse, and check if the fuse is blown. If blown, be sure to replace it with the fuse with the same specification.
3. Close the fuse box cover and install the seat cushion.

### Battery Dead

Please charge the battery using a dedicated motorcycle lithium battery charger. Remove the battery from the motorcycle before charging. If the battery does not recover after charging, please contact the KOVEMOTO authorized repair shop.

#### Notes

- Avoid using a car battery charger or a motorcycle lithium battery charger for charging, as this may result in battery damage or even a fire.
- Before handling the fuse, please refer to “Inspect and replace the fuses”.
- The bidirectional diode is not a fuse; it is part of the starting control circuit. Damage to this component will result in a no-start condition.

# Relevant Information

Key.....	66
Maintenance of Motorcycle Instruments, Controls, and Other Features.....	67
Motorcycle Care.....	68
Motorcycle Parking.....	71
Motorcycle Transport.....	71
You and Your Environment.....	72
Vehicle Identification Number, Engine Number, and Nameplate.....	73
Catalytic Converter.....	74

## Electrical Malfunction

### Fuse Blown



The motorcycle comes with two ignition keys, which are used to start the engine.

- Do not bend the key or subject it to excessive pressure.
- Avoid prolonged exposure to direct sunlight or high-temperature environments.
- Do not grind, bore, or alter its shape in any way.

#### Notes

- To prevent loss, please keep your key safe. If you are concerned about losing it, make a duplicate immediately.

## Instrument, Controls and Other Functions

### Ignition Switch, Engine OFF Switch

#### Ignition switch

1. When parked, please set the ignition switch to the "OFF" or "LOCK" position to avoid unnecessary battery drain. Excessive battery drain may prevent starting.

2. Do not turn the key while riding.

#### Engine OFF Switch

Do not use the engine OFF switch unless in an emergency. Doing so while riding will cause the engine to stop suddenly, making the ride unsafe.

### Odometer, Trip Meter (Sub-total)

#### Odometer

When the reading exceeds 999,999, the display will lock at 999,999. Trip Meter

When the reading exceeds 999.9, the display will automatically reset to zero.

## Motorcycle Care

Regular cleaning and polishing ensure a long motorcycle lifespan. A clean motorcycle makes it easier to spot potential faults. It is particularly noteworthy that anti-icing seawater and salt scattered on the road can accelerate corrosion. Be sure to clean the motorcycle thoroughly after driving on the coastal or above-mentioned road.

### Cleaning

Wait for the engine, muffler, brakes, and other high-temperature components to cool before cleaning.

1. Thoroughly rinse the motorcycle with a low-pressure hose to remove loose dirt.
2. If necessary, use a sponge or soft towel dipped in mild detergent to remove dust and dirt.
3. Thoroughly rinse the motorcycle with ample clean water and dry it using a clean, soft cloth.
4. After drying the motorcycle, lubricate the moving parts, ensuring that no lubricant splashes onto the brakes or tires. Oil-contaminated brake discs, brake pads, brake drums, or brake shoes can significantly reduce braking performance and may lead to accidents.
5. After washing and drying the motorcycle, lubricate the drive chain promptly.
6. Waxing helps prevent corrosion.

Avoid using products containing strong detergents or chemical solvents, as these substances can damage the motorcycle's metal parts, paint, and plastic components. Do not wax the tires and brakes.

If your motorcycle has parts with a matte finish, avoid waxing these matte surfaces.

## Cleaning Precautions

- Avoid using a high-pressure water jet:
  - ▶ High-pressure water jets can damage moving parts and electrical components, rendering them irreparable.
  - ▶ Moisture from the intake port may be drawn into the throttle body or enter the air filter.
- Avoid direct water rinsing of the muffler:
  - ▶ Water in the muffler may cause starting problems and rust. If detected, remove all traces and dirt immediately.
- Dry the brakes:
  - ▶ Water reduces braking performance. After washing, intermittently use the brakes at low speed, repeatedly pressing the brake pedal lightly to generate heat from friction, drying the water until braking efficiency is restored.
- Avoid direct water contact beneath the seat cushion:
  - ▶ Water entering under the seat cushion may damage electrical appliance parts.
- Avoid rinsing the air filter directly with water.
  - ▶ If the air filter gets wet, the engine may fail to start.
- Avoid direct water contact near the headlight:
  - ▶ After washing or riding in the rain, the internal lens of the headlight may temporarily fog up, but this does not affect its functionality. However, if you notice a significant accumulation of water or ice inside the lens, have it inspected by an authorized KOVEMOTO motorcycle service center.
- Avoid waxing or polishing matte finishes:
  - ▶ Use sufficient water and a mild cleanser to clean matte paint surfaces, and dry them with a clean, soft cloth.

## Aluminum Components

Aluminum corrodes when exposed to dirt, mud, or salt. Regularly clean aluminum components and follow these guidelines to prevent scratches:

- Avoid using stiff brushes, steel wool, or any abrasive cleaning materials.
- Do not drive or scrape against the curb.

## Panel

Follow these guidelines to prevent scratches and damage:

- Gently clean with a sponge and sufficient water.
- Clean with diluted detergent and rinse thoroughly with ample water to remove stubborn stains.
- Avoid exposing the instrument panel and lamp covers to corrosive liquids like gasoline and brake fluid.

### Notes

- Remove all traces and dirt immediately upon noticing rust in the muffler.

## Muffler

The muffler can also get dirty from mud or dust. Use a wet sponge with cleaning agent to remove the mud or dust, then rinse thoroughly with clear water, and dry with suede or a soft towel. If necessary, burn marks can be removed with a commercially available compound of fine texture, and then rinsed in the same manner as mud and dust.

If the muffler is painted, use a neutral detergent to clean the exhaust pipe and the painted surface of the muffler. If you are unsure whether the muffler is painted, please contact the KOVEMOTO authorized repair shop.

## Motorcycle Parking

If you leave your motorcycle outdoors, you should consider using a full motorcycle cover. If you do not ride for an extended period of time, please follow these guidelines:

- Wash the motorcycle and wax all painted surfaces (excluding matte finishes), then apply anti-rust oil to all chrome parts.
- Lubricate the drive chain.
- Place the motorcycle on a maintenance stand and elevate it with wooden blocks to ensure both tires are off the ground.
- After rain, remove the body cover and dry it in a ventilated place.
- Remove the battery to avoid discharging.

Fully charge the battery and store it in a cool, well-ventilated area. If you leave the battery in place, disconnect the negative terminal to prevent discharge. Before reusing a stored motorcycle, inspect all items as specified in the maintenance interval table.

## Motorcycle Transport

If you need to transport your motorcycle, use a motorcycle trailer, loading ramp, or flatbed truck equipped with a lifting platform, and secure it with motorcycle tie-down straps. Never attempt to tow a motorcycle with its wheels on the ground.

### Notes

- Towing a motorcycle can severely damage the drivetrain.

## You and Your Environment

Owning and riding a motorcycle is an enjoyable experience, but you must take responsibility for protecting the environment.

## Select The Appropriate Detergent

Use biodegradable detergents when washing your motorcycle, and avoid sprays containing chlorofluorocarbons (CFCs) as they harm the protective ozone layer in the atmosphere.

## Waste Recycling

Sort the oil and other toxic wastes into approved containers and send them to the recycling center. Call the local national public affairs or environmental service office for the recycling center in your area and the disposal method of non-recyclable wastes. Do not pour used engine oil into trash cans, sewers or ground, because the used oil, gasoline, coolant and cleaning solvent contain toxic substances, which will hurt cleaners, pollute drinking water, lakes, rivers and seas.

## Vehicle Identification Number, Engine Number, and Nameplate

When registering a motorcycle, you must provide the vehicle identification number and engine number. These unique identifiers are used to distinguish your motorcycle. When ordering replacement parts, ensure you record these numbers and store them in a secure location.

### Vehicle Identification Number (VIN)

The VIN is engraved on the right side of the frame upright tube



### Engine Number

The engine number is engraved on the crankcase, which locates at the right side of crankcase upper.



### Nameplate

The nameplate is attached to the frame right head tube.



## Catalytic Converter

This motorcycle is equipped with a three-way catalytic converter. The catalytic converter contains precious metals as catalysts for high-temperature chemical reactions, transforming hydrocarbons (HC), carbon monoxide (CO), and nitrogen oxides (NOx) in the exhaust into compliant mixtures.

A faulty catalytic converter can pollute the air and reduce your engine's performance. When replacing it, always use genuine KOVEMOTO motorcycle parts.

Follow these guidelines to safeguard your motorcycle's catalytic converter:

- Only unleaded gasoline should be used, as leaded gasoline can damage the catalytic converter.
- Maintain the engine in optimal operating condition.
- If the engine fails to start, backfires, stalls, or exhibits other poor performance, stop riding immediately and turn off the engine. Have the motorcycle inspected by an authorized KOVEMOTO motorcycle service center.

# Technical Parameters

Vehicle-Related Parameters .....	76
Torque Parameters .....	78
Vehicle Body Bolt Torque.....	79

## Vehicle-Related Parameters -1

Vehicle Model	KY600	Engine Model	Z2V72MS
Overall length (mm)	2220	Cylinder diameter (mm) × Stroke (mm)	72.0×71.0
Overall width (mm)	800	Compression ratio	12:1
Overall height (mm)	1115	Maximum power (kw/r/min)	38.5 ± 2% / 8500 ± 1.5%
Wheelbase (mm)	1490	Maximum torque (N·m/rpm)	52.0 ± 2% / 6000 ± 1.5%
Wheelbase (mm)	/	Idle speed (rpm)	1400±100
Curb weight (kg)	205	Cylinder capacity (mL)	578
Payload (kg)	150	Spark plug	LMAR8J-9E
Front tire specifications	120/70 R18	Spark plug gap (mm)	0.8-0.9
Rear tire specifications	160/60 R16	Valve clearance (mm)	Intake valve: 0.10±0.03
Maximum speed (km/h)	170		Exhaust valve: 0.15±0.03

## Vehicle-Related Parameters -2

Lubricating oil capacity (L)	2.9		Main fuse	40A
Fuel capacity (L)	Main: 15.8	Auxilliary: 4.2	Neutral indicator light	LED lamp
Primary transmission ratio	1.946		Headlight	LED lamp
First gear	3.285		Front position lamp	LED lamp
Second gear	2.105		Rear taillight/Brake lamp	LED lamp
Third gear	1.600		Front turn signal	LED lamp
Fourth gear	1.300		Rear turn signal	LED lamp
Fifth gear	1.150		Rear license plate lamp	LED lamp
Sixth gear	1.043		Turn indicator light	LED lamp
Final transmission ratio	2.464		Instrument indicator light	LED lamp
Battery	12V11.2Ah (lead-acid battery)		Ignition mode	ECU controls ignition

## Torque Parameters

Fastener Type	Torque	Fastener Type	Torque
5mm bolt and nut	6	6mm Screw	8
6mm bolt and nut	12	6mm flange bolt (8mm head, small flange)	10
8mm bolt and nut	22	6mm flange bolt (8mm head, large flange)	12
10mm bolt and nut	60	6mm flange bolt (10mm head) and nuts	12
12mm bolt and nut	80	8mm Flange Bolt and Nut	22
5mm Screw	5	/	/

### Notes

- Except for the specified torque, the standard torque values in the above table apply to this vehicle.

## Vehicle Body Bolt Torque

Item	Thread Diameter (mm)	Torque (N·m)	Notes
ABS ring gear and rear aluminum wheel	M5	6	
ABS ring gear and front aluminum wheel	M5	6	
ABS and ABS bracket	M6	8	
ABS and brake hose	M10	25	
ABS bracket and frame	M6	12	
ECU and rear fender front section	ST4.8	2	
Shift rod mounting screw	M6	10	
Adjusting and tightening nut of the shift rod	M5	5	
Shift pedal assembly and front footpeg bracket - left	M8	22	
Shift rockerarm and engine gear shift lever	M6	10	
Side mounting brackets (left and right) and rear fuel tank	M6	10	
Side cover and side mounting bracket	M6	10	
Side tilt sensor	M5	4	
Side stand OFF switch	M6	10	
Frame and front windshield bracket	M6	4	
Frame trim and side mounting bracket	M6	4	
Frame trim and frame	M8	22	
Water reservoir and frame	M6	10	
Water reservoir trim and water reservoir	M5	8	
Drive belt cover - upper/lower and swingarms	M6	10	

Item	Thread Diameter (mm)	Torque (N·m)	Notes
Drive belt lower cover - inner and drive belt lower cover - outer	ST4.8	1	
Large pulley and buffer body	M8	30	
Headlight mounting bracket and upper connecting plate	M6	10	
Headlight bracket pressure plate and headlight	M6	10	
Headlight bracket and upper connecting plate	M6	10	
Idle stepper motor mounting screw	ST4.8	2.5	
Ignition lock cover	M5	3	
Ignition lock and upper connection plate	M6	10	
Ignition coil and frame	M6	10	
Battery box and frame	M6	10	
Regulating rectifier	M6	12	
Engine fuel drain bolt	M12	28	
Engine rear (upper) and frame	M10	60	
Engine rear (lower) and frame	M10	60	
Engine intake pipe assembly and engine	M6	10	
Engine front suspension (upper) and engine	M10	60	
Engine front suspension (lower) and engine	M10	60	
Engine front suspension (left and right) and frame	M8	22	
Engine upper suspension - right and frame	M8	22	
Engine lower protector	M6	10	
Engine front sprocket cover and engine front sprocket bracket	M6	12	
Engine front sprocket bracket mounting bolt	M6	12	

Item	Thread Diameter (mm)	Torque (N·m)	Notes
Upper clamp and lower socket of the steering handlebar	M8	22	
Heat shield, outer layer of heat shield, and rear section of muffler	M6	8	
Steel strap hook and front fuel tank	M5	3	
Rear fender liner panel, front section of rear fender, and license plate mounting bracket	M5	8	
Rear fender front section and frame - upper	M6	4	
Rear fender front section and frame - lower	M6	5	
Rear fender front section and frame - left and right	M6	4	
Rear disc brake and rear wheel hub	M8	30	
Rear grab handle and frame	M8	22	
Rear shock absorber upper end and frame	M10	60	
Rear shock absorber lower end and swingarm	M10	60	
Rear footpeg assembly - right and muffler mounting bracket	M8	22	
Rear footpeg bracket assembly -left/right and frame	M10	45	
Rear wheel axle locking nut	M16	108	
Rear fuel tank and frame	M6	12	
Rear brake pump push rod adjusting and tightening nut	M5	6	
Rear brake pump assembly and front footpeg - right	M6	10	
Rear brake caliper and rear brake caliper bracket	M8	22	
Rear brake caliper and rear brake hose	M10	32	
Rear brake switch	M10	25	
Spark plug installation	M10	14	

Item	Thread Diameter (mm)	Torque (N·m)	Notes
Oil Filter Cover	3/4-UNF (2B)	12	
Water inlet assembly and frame	M6	10	
Accelerator mounting screw	ST4.8	2	
Throttle cable bracket mounting screw	M5	3.5	
Throttle valve and Intake manifold	M6	10	
Thermostat cover mounting bolt	M6	10	
Intake manifold locking pipe clamp screw	M5	3	
Air filter locking pipe clamp screw	M5	3	
Air filter element and air filter inner cover	M6	4	
Air filter element bracket and air filter element	M6	4	
Air filter inner cover and air filter bracket	M6	10	
Air filter outer cover and air filter element bracket	M8	22	
Air filter outer cover and left fuel tank side trim	M8	22	
Air filter bracket and engine	M6	10	
Horn installation	M6	12	
Cooling pump cover mounting bolt	M6	10	
Clutch lever assembly mounting bolt	M6	10	
Chain adjuster locking nut	M8	16	
License plate mounting	M6	8	
License plate mounting bracket and rear reflector	M5	4	
License plate mounting bracket and rear tailgate	M6	10	
License plate mounting bracket and license plate lamp bracket	M5	4	

Item	Thread Diameter (mm)	Torque (N·m)	Notes
License plate mounting bracket and taillight assembly	M6	4	
License plate lamp bracket and license plate lamp	ST3.5	1	
Fuel injector cap and intake manifold assembly	M6	8	
Swingarm shaft locking	M16	88	
Front side plate frame and chassis	M6	12	
Side cover - left and right and frame	M6	10	
Headlight and frame	M6	10	
Headlight and headlight trim	ST4.8	1	
Front windshield and front windshield bracket	M5	4	
Front fender and front fender bracket	M6	4	
Front disc brake and front wheel hub	M8	30	
Front and rear wheel speed sensors	M6	8	
Front and rear brake pumps and brake hoses	M10	32	
Rear brake fluid reservoir cap fastening screw	M5	2	
Front shock absorber adjuster end cover bolt	M8	22	
Front shock absorber and front wheel axle locking	M8	22	
Front shock absorber trim cover and front shock absorber	M6	10	
Front fender bracket and front shock absorber	M6	4	
Front shock absorber damper bottom bolt	M10	45	
Front footpeg bracket - L/R and frame	M10	45	
Front wheel axle locking	M16	70	
Front fuel tank and frame	M6	10	

Item	Thread Diameter (mm)	Torque (N·m)	Notes
Front fuel tank and fuel tank trim	M5	5	
Front brake pump mounting bolts	M6	10	
Front brake caliper and front shock absorber	M10	45	
Front brake caliper and brake hose 2	M10	32	
Fuel pump and rear fuel tank	M5	5	
Three-in-one sensor mounting screw	ST4.8	2.5	
Radiator fan and radiator assembly	M6	8	
Radiator grille and frame	M6	10	
Radiator assembly and frame	M6	10	
Brake rockerarm and front footpeg bracket-right	M8	22	
Upper connecting plate wire hook and upper connecting plate	M5	5	
Upper connecting plate locking bolt	M14	80	
Upper connecting plate and front shock absorber (locking)	M8	22	
Handlebar switch - left/right mounting screw	ST4.8	2	
Handlebar switch-left and handlebar connecting bolt	M5	5	
Double-threaded stud to lower socket of steering handlebar	M10	30	
Double-threaded stud and upper connecting plate locking nut	M8	22	
Water radiator trim and front side cover	M4	4	
Lower connecting plate and front shock absorber (locking)	M8	22	
Junction box and frame	M6	10	
Wire clip and frame	ST4.8	1	
Cable and rear fender front section	ST4.8	1	

Item	Thread Diameter (mm)	Torque (N·m)	Notes
Wiring harness clamp and frame	M6	8	
Muffler pipe clamp	M8	22	
Muffler rear section and muffler mounting bracket	M8	22	
Muffler front section and engine	M8	22	
Small pulley locking nut	M16	100	
Battery positive and negative terminal connecting screw	M5	2	
Oxygen sensor and engine	M12	20	
Instrument bracket and steering handlebar lower socket	M6	10	
Instrument bracket and instrument assembly	M5	4	
Oil pipe connector and rear fuel tank	M5	4	
Accelerator cable A/B (steering handlebar end)	M5	4	
Accelerator cable A/B (throttle end)	M5	6	
Throttle cable and accelerator connecting screw	M5	4	
Fuel level sensor and front fuel tank	M6	8	
Fuel tank side protector bracket-left and engine	M6	10	
Fuel tank side trim inner panel and frame	M6	10	
Inner panel of fuel tank side trim and rear fuel tank	M6	10	
Fuel tank side trim bracket - left and engine	M6	10	
Fuel tank side trim-left and fuel tank side protector bracket-left	M6	10	
Fuel tank lock rubber ring and front fuel tank	M5	1	
Brake caliper bleed screw	M5	6	
Brake hose 2 and lower connecting plate	M6	8	

Item	Thread Diameter (mm)	Torque (N·m)	Notes
Brake hose 4 and swingarm	M6	8	
Main cable and frame	M6	8	
Turn signal fastening nut	M10	5	
Damper inner rod and regulator end cap tightening nut	M6	15	
Seat cushion lock and frame	M6	10	
Side stand	M10	Fasten the bolt to 10 N·m and loosen by 1/3 turn, then hold the bolt head steady and tighten the locking nut to a torque of 22 N·m.	
Steering stem locking 4-slot adjusting nut	M25	Stage 1: Tighten to 45 N·m. Stage 2: Loosen the adjusting nut 180°, then retighten to 15 N·m. Stage 3: Back off an additional 90°.	